

# TC8300

## Touch Computer



## Integrator Guide for Android™ 8.1 Oreo



**ZEBRA**

## Copyright

ZEBRA and the stylized Zebra head are trademarks of Zebra Technologies Corporation, registered in many jurisdictions worldwide. Google, Android, Google Play and other marks are trademarks of Google LLC; Oreo is a trademark of Mondelez International, Inc. group. All other trademarks are the property of their respective owners. ©2019 Zebra Technologies Corporation and/or its affiliates. All rights reserved.

COPYRIGHTS & TRADEMARKS: For complete copyright and trademark information, go to [www.zebra.com/copyright](http://www.zebra.com/copyright).

WARRANTY: For complete warranty information, go to [www.zebra.com/warranty](http://www.zebra.com/warranty).

END USER LICENSE AGREEMENT: For complete EULA information, go to [www.zebra.com/eula](http://www.zebra.com/eula).

## Terms of Use

- Proprietary Statement

This manual contains proprietary information of Zebra Technologies Corporation and its subsidiaries (“Zebra Technologies”). It is intended solely for the information and use of parties operating and maintaining the equipment described herein. Such proprietary information may not be used, reproduced, or disclosed to any other parties for any other purpose without the express, written permission of Zebra Technologies.

- Product Improvements

Continuous improvement of products is a policy of Zebra Technologies. All specifications and designs are subject to change without notice.

- Liability Disclaimer

Zebra Technologies takes steps to ensure that its published Engineering specifications and manuals are correct; however, errors do occur. Zebra Technologies reserves the right to correct any such errors and disclaims liability resulting therefrom.

- Limitation of Liability

In no event shall Zebra Technologies or anyone else involved in the creation, production, or delivery of the accompanying product (including hardware and software) be liable for any damages whatsoever (including, without limitation, consequential damages including loss of business profits, business interruption, or loss of business information) arising out of the use of, the results of use of, or inability to use such product, even if Zebra Technologies has been advised of the possibility of such damages. Some jurisdictions do not allow the exclusion or limitation of incidental or consequential damages, so the above limitation or exclusion may not apply to you.

## Revision History

Changes to the original guide are listed below:

Change	Date	Description
-01 Rev A	04/2019	Initial release.
-02 Rev A	09/2019	Updated to include the DPM configuration, DPM accessories, and SE4770-SR.
-03 Rev A	11/2019	Updated the Decode Range distances.
-04 Rev A	11/2021	Updated GMS Restricted.

# Table of Contents

Copyright .....	2
Terms of Use .....	2
Revision History .....	2
<b>About This Guide .....</b>	<b>11</b>
Introduction .....	11
Configurations .....	11
Software Versions .....	13
Notational Conventions .....	13
Service Information .....	14
<b>Getting Started .....</b>	<b>16</b>
Introduction .....	16
Unpacking .....	16
Removing the Screen Protection Film .....	16
Features .....	17
Setup .....	19
Installing the microSD Card .....	19
Installing the Battery .....	22
Charging the Battery .....	23
Powering on the Device .....	24
Resetting the TC8300 .....	25
Performing a Soft Reset .....	25
Performing a Hard Reset .....	25
Performing an Enterprise Reset .....	26
Performing a Factory Reset .....	26
<b>Accessories .....</b>	<b>28</b>
Introduction .....	28

2-Slot USB Charge Cradle .....	30
Setup .....	32
Charging the Device .....	33
Charging the Spare Battery .....	34
Battery Charging .....	34
Main Battery Charging .....	34
Spare Battery Charging .....	34
Charging Temperature .....	34
5-Slot Charge Only Cradle .....	34
Setup .....	35
Charging the Device .....	35
Battery Charging .....	36
Main Battery Charging .....	36
Charging Temperature .....	36
5-Slot Charge Only Cradle with Battery Charger .....	36
Setup .....	37
Charging the Device .....	37
Battery Charging .....	38
Main Battery Charging .....	38
Spare Battery Charging .....	38
Charging Temperature .....	38
5-Slot Ethernet Cradle .....	39
Charging the Device .....	40
Battery Charging .....	41
Main Battery Charging .....	41
Charging Temperature .....	41
Daisy-chaining Ethernet Cradles .....	41
Ethernet Settings .....	42
Configuring for a Proxy Server .....	42
Configuring Ethernet Static IP Address .....	43
LED Indicators .....	44
Establishing Ethernet Connection .....	44
5-Slot Ethernet Cradle with Battery Charger .....	45
Setup .....	46
Charging the Device .....	46
Battery Charging .....	47
Main Battery Charging .....	47
Spare Battery Charging .....	47
Charging Temperature .....	47
Daisy-chaining Ethernet Cradles .....	48
Ethernet Settings .....	48
Establishing Ethernet Connection .....	48
4-Slot Battery Charger .....	48

## Table of Contents

Setup .....	49
Charging Spare Batteries .....	49
Charging Temperature .....	50
2-Slot Desk Bracket .....	50
Assembly .....	50
Mounting Cradle .....	51
5-Slot Desktop Bracket .....	52
Assembly .....	52
Mount Cradle .....	53
Cart Mount .....	54
Installation .....	55
5-Slot Cradle Rack Installation .....	56
4-Slot Battery Chargers Rack Installation .....	60
Rack Mount Installation .....	63
5-Slot Cradle Wall Installation .....	66
Bottom Tray Assembly .....	66
Bracket Wall Mounting .....	66
4-Slot Battery Charger Wall Installation .....	69
Bottom Tray Assembly .....	69
Bracket Wall Mounting .....	69
Condensation Resistant Rear Bezel Replacement .....	71
<b>USB Communication .....</b>	<b>75</b>
Introduction .....	75
Transferring Files with a Host Computer via USB .....	75
Transferring Files .....	75
Connecting to the TC8300 as a Media Device .....	76
Connecting to the TC8300 as a Camera .....	76
Disconnect from the Host Computer .....	76
<b>DataWedge .....</b>	<b>77</b>
Introduction .....	77
Accessing DataWedge .....	77
Basic Scanning .....	77
Profiles .....	77
Profile0 .....	78
Plug-ins .....	78
Input Plug-ins .....	78
Process Plug-ins .....	78
Output Plug-ins .....	79

## Table of Contents

Profiles Screen .....	79
Profile Context Menu .....	79
Options Menu .....	80
Disabling DataWedge .....	80
Creating a New Profile .....	80
Profile Configuration .....	81
Associating Applications .....	82
Data Capture Plus .....	83
Barcode Input .....	85
Enabled .....	85
Scanner Selection .....	85
Hardware Trigger .....	86
Auto Switch to Default on Event .....	86
Configure Scanner Settings .....	86
Select Scanner to Set Parameters .....	87
Decoders .....	87
Decoder Params .....	90
UPC EAN Params .....	95
Reader Params .....	98
Scan Params .....	101
UDI Params .....	102
Multibarcodes .....	103
Keep enabled on suspend .....	103
Voice Input .....	103
Keystroke Output .....	104
Intent Output .....	105
Intent Overview .....	106
IP Output .....	107
Usage .....	108
Using IP Output with IPWedge .....	108
Using IP Output without IPWedge .....	109
Generating Advanced Data Formatting Rules .....	111
Configuring ADF Plug-in .....	111
Creating a Rule .....	111
Defining a Rule .....	112
Defining Criteria .....	112
Defining an Action .....	114
Deleting a Rule .....	114
Order Rules List .....	115
Deleting an Action .....	116
ADF Example .....	116
DataWedge Settings .....	119
Importing a Configuration File .....	120
Exporting a Configuration File .....	120
Importing a Profile File .....	120

## Table of Contents

Exporting a Profile .....	121
Restoring DataWedge .....	121
Configuration and Profile File Management .....	121
Enterprise Folder .....	121
Auto Import .....	122
Reporting .....	122
Programming Notes .....	122
Overriding Trigger Key in an Application .....	122
Capture Data and Taking a Photo in the Same Application .....	122
Disable DataWedge on Device and Mass Deploy .....	123
DataWedge APIs .....	123
Soft Scan Trigger .....	123
Function Prototype .....	123
Parameters .....	123
Scanner Input Plugin .....	123
Function Prototype .....	124
Parameters .....	124
Return Values .....	124
Example .....	125
Comments .....	125
Enumerate Scanners .....	125
Function Prototype .....	125
Parameters .....	125
Return Values .....	126
Example .....	127
Comments .....	127
Set Default Profile .....	128
Default Profile Recap .....	128
Usage Scenario .....	128
Function Prototype .....	128
Parameters .....	128
Return Values .....	128
Example .....	129
Comments .....	129
Reset Default Profile .....	129
Function Prototype .....	130
Parameters .....	130
Return Values .....	130
Example .....	130
Comments .....	130
Switch To Profile .....	131
Profiles Recap .....	131
Usage Scenario .....	131
Function Prototype .....	131
Parameters .....	131

## Table of Contents

Return Values .....	132
Example .....	132
Comments .....	132
Notes .....	133
<b>Settings.....</b>	<b>134</b>
Introduction .....	134
Setting Screen Lock .....	134
Setting Screen Lock Using PIN .....	135
Setting Screen Unlock Using Password .....	135
Setting Screen Unlock Using Pattern .....	136
Showing Passwords .....	137
Language Usage .....	137
Changing the Language Setting .....	137
Adding Words to the Dictionary .....	138
Keyboard Settings .....	138
Button Remapping .....	138
Remapping a Button .....	138
PTT Express Configuration .....	139
Importing a PTT Express Configuration File .....	139
RxLogger .....	139
RxLogger Settings .....	140
RxLogger Configuration .....	140
ANR Module .....	141
Kernal Module .....	141
Logcat Module .....	142
LTS Module .....	143
Ramoops Module .....	143
Qxdm Module .....	143
Resource Module .....	144
Snapshot Module .....	144
TCPDump Module .....	145
Tombstone Module .....	145
Configuration File .....	145
Enabling Logging .....	145
Disabling Logging .....	146
Extracting Log Files .....	146
RxLogger Utility .....	147
App View .....	147
Viewing Logs .....	147
Backup .....	149



## Table of Contents

Archive Data .....	149
Overlay View .....	149
Initiating the Main Chat Head .....	150
Removing the Main Chat Head .....	150
Viewing Logs .....	150
Removing a Sub Chat Head Icon .....	151
Backing Up In Overlay View .....	151
About Phone .....	151
<b>Application Deployment.....</b>	<b>153</b>
Introduction .....	153
Security .....	153
Secure Certificates .....	153
Installing a Secure Certificate .....	153
Configuring Credential Storage Settings .....	154
Development Tools .....	154
Android .....	154
GMS Restricted .....	155
ADB USB Setup .....	155
Application Installation .....	155
Installing Applications Using the USB Connection .....	156
Installing Applications Using the Android Debug Bridge .....	157
Installing Applications Using a microSD Card .....	158
Uninstalling an Application .....	159
System Update .....	160
Storage .....	161
Random Access Memory .....	162
External Storage .....	162
Internal Storage .....	163
Enterprise Folder .....	164
App Management .....	164
Viewing App Details .....	165
Managing Downloads .....	166
<b>Maintenance and Troubleshooting .....</b>	<b>167</b>
Introduction .....	167
Maintaining the Device .....	167
Battery Safety Guidelines .....	167
Long Term Storage .....	168
Cleaning Instructions .....	168
Approved Cleanser Active Ingredients .....	168

## Table of Contents

Harmful Ingredients .....	168
Device Cleaning Instructions .....	169
Special Cleaning Notes .....	169
Cleaning Materials Required .....	169
Cleaning Frequency .....	169
Cleaning the Device .....	169
Housing .....	169
Display .....	170
Exit Window .....	170
Cleaning Battery Connectors .....	170
Cleaning Cradle Connectors .....	170
Troubleshooting .....	171
TC8300 .....	171
Cradles .....	172
<b>Specifications.....</b>	<b>173</b>
Technical Specifications .....	173
TC8300 .....	173
SE965 Standard Range Laser Decode Zones .....	176
SE4750-MR Decode Zones .....	177
SE4750-DP Decode Zones .....	178
SE4750-DPW Decode Zones .....	179
SE4770-SR Decode Zones .....	180
SE4850 Decode Zones .....	181
I/O Connector Pin-Outs .....	182
2-Slot USB Charge Cradle Technical Specifications .....	183
2-Slot DPM USB Charge Cradle Technical Specifications .....	184
5-Slot Charge Only Cradle Technical Specifications .....	184
5-Slot Charge Only Cradle with Battery Charger Technical Specifications .....	185
5-Slot Ethernet Cradle Technical Specifications .....	185
5-Slot Ethernet Cradle with Battery Charger Technical Specifications .....	186
4-Slot Battery Charger Technical Specifications .....	186
USB and Charging Cable Technical Specifications .....	187
Quick Disconnect Audio Cable Technical Specifications .....	187
3.5 mm Audio Cable Technical Specifications .....	187

## Index

# About This Guide

## Introduction

This guide provides information about using the device and accessories.



**NOTE:** Screens and windows pictured in this guide are samples and can differ from actual screens.

## Configurations

The TC8300 includes standard, condensation resistant, and premium configurations.

Table 1 Configurations

Configuration	Radios			Data Capture					13 MP Camera	4" WVGA Color	Memory		OS	Sensors				Apps	Vibration	
	802.11 a/b/g/n/ac	Bluetooth 5.0	NFC	SE865 Laser Engine	SE4750-MR Imager	SE4750-DP Imager	SE4750-DPA Imager	SE4770-SR Imager			SE4850 Imager	4G RAM/32 GB Flash		8G RAM/128 GB Flash	Android/GMS V8.1.0	Accelerometer	Proximity Sensor		Gyroscope	Magnet
<b>Base</b>																				
TC83B0-A005A510NA	x	x		x						x	x		x	x		x		x	x	
TC83B0-2005A510NA	x	x			x					x	x		x	x		x		x	x	
TC83B0-3005A510NA	x	x						x		x	x		x	x		x		x	x	
TC83B0-6005A510NA	x	x					x			x	x		x	x		x		x	x	
TC83B0-A005A510RW	x	x		x						x	x		x	x		x		x	x	
TC83B0-2005A510RW	x	x			x					x	x		x	x		x		x	x	
TC83B0-3005A510RW	x	x						x		x	x		x	x		x		x	x	
TC83B0-6005A510RW	x	x					x			x	x		x	x		x		x	x	
TC83B0-2005A510CN	x	x			x					x	x		x	x		x		x	x	
TC83B0-3005A510CN	x	x						x		x	x		x	x		x		x	x	
TC83B0-6005A510CN	x	x					x			x	x		x	x		x		x	x	
TC83B0-2005A510IN	x	x			x					x	x		x	x		x		x	x	
TC83B0-3005A510IN	x	x						x		x	x		x	x		x		x	x	
TC83B0-6005A510IN	x	x					x			x	x		x	x		x		x	x	
<b>Condensation Resistant</b>																				
TC83B0-2005A61CNA	x	x			x					x	x		x	x		x		x	x	x
TC83B0-3005A61CNA	x	x						x		x	x		x	x		x		x	x	x
TC83B0-6005A61CNA	x	x					x			x	x		x	x		x		x	x	x
TC83B0-2005A61CRW	x	x			x					x	x		x	x		x		x	x	x

**Table 1 Configurations**

Configuration	Radios			Data Capture						13 MP Camera	4" WVGA Color	Memory		OS	Sensors				Apps	Vibration	
	802.11 a/b/g/n/ac	Bluetooth 5.0	NFC	SE965 Laser Engine	SE4750-MR Imager	SE4750-DP Imager	SE4750-DPA Imager	SE4770-SR Imager	SE4850 Imager			4G RAM/32 GB Flash	8G RAM/128 GB Flash		Android/GMS V8.1.0	Accelerometer	Proximity Sensor	Gyroscope		Magnet	ATTE
TC83B0-3005A61CRW	x	x						x		x	x		x	x		x		x	x	x	
TC83B0-6005A61CRW	x	x					x			x	x		x	x		x		x	x	x	
TC83B0-2005A61CCN	x	x			x					x	x		x	x		x		x	x	x	
TC83B0-3005A61CCN	x	x						x		x	x		x	x		x		x	x	x	
TC83B0-2005A61CIN	x	x			x					x	x		x	x		x		x	x	x	
TC83B0-3005A61CIN	x	x						x		x	x		x	x		x		x	x	x	
<b>Package 1</b>																					
TC83BH-2205A710NA	x	x	x		x					x	x	x		x	x	x	x	x	x	x	
TC83BH-3205A710NA	x	x	x					x		x	x	x		x	x	x	x	x	x	x	
TC83BH-6205A710NA	x	x	x				x			x	x	x		x	x	x	x	x	x	x	
TC83BH-2205A710RW	x	x	x		x					x	x	x		x	x	x	x	x	x	x	
TC83BH-3205A710RW	x	x	x					x		x	x	x		x	x	x	x	x	x	x	
TC83BH-6205A710RW	x	x	x				x			x	x	x		x	x	x	x	x	x	x	
TC83BH-2205A710CN	x	x	x		x					x	x	x		x	x	x	x	x	x	x	
TC83BH-3205A710CN	x	x	x					x		x	x	x		x	x	x	x	x	x	x	
TC83BH-2205A710IN	x	x	x		x					x	x	x		x	x	x	x	x	x	x	
TC83BH-3205A710IN	x	x	x					x		x	x	x		x	x	x	x	x	x	x	
<b>Package 2 High Memory</b>																					
TC83BH-2206A710NA	x	x	x		x					x	x		x	x	x	x	x	x	x	x	
TC83BH-3206A710NA	x	x	x					x		x	x		x	x	x	x	x	x	x	x	
TC83BH-6206A710NA	x	x	x				x			x	x		x	x	x	x	x	x	x	x	
TC83BH-6206A710RW	x	x	x				x			x	x		x	x	x	x	x	x	x	x	
TC83BH-2206A710RW	x	x	x		x					x	x		x	x	x	x	x	x	x	x	
TC83BH-3206A710RW	x	x	x					x		x	x		x	x	x	x	x	x	x	x	
<b>DPM</b>																					
TC83B0-4005A610NA	x	x				x					x	x		x	x		x		x	x	
TC83B0-4005A610RW	x	x				x					x	x		x	x		x		x	x	
TC83B0-4005A610CN	x	x				x					x	x		x	x		x		x	x	
TC83B0-5005A610NA	x	x					x				x	x		x	x		x		x	x	
TC83B0-5005A610RW	x	x					x				x	x		x	x		x		x	x	
TC83B0-5005A610CN	x	x					x				x	x		x	x		x		x	x	
TC83B0-4005A610IN	x	x				x					x	x		x	x		x		x	x	
TC83B0-5005A610IN	x	x					x				x	x		x	x		x		x	x	
<b>TAA</b>																					
TC83B0-2005A510TA	x	x			x						x	x		x	x		x		x		
TC83B0-3005A510TA	x	x						x			x	x		x	x		x		x		
TC83B0-6005A510TA	x	x					x				x	x		x	x		x		x		
TC83BH-6205A710TA	x	x	x					x		x	x	x		x	x	x	x	x	x	x	
TC83BH-2205A710TA	x	x	x		x					x	x	x		x	x	x	x	x	x	x	
TC83BH-3205A710TA	x	x	x					x		x	x	x		x	x	x	x	x	x	x	

## Software Versions

To determine the current software versions:

1. Swipe down from the Status bar to open the Quick Settings bar.
2. Touch **⚙️ > System**.
3. Touch **About phone**.
4. Scroll to view the following information:
  - **Status**
  - **Battery information**
  - **SW components**
  - **Legal information**
  - **Model**
  - **Android version**
  - **Android security patch level**
  - **Kernel version**
  - **Build Fingerprint**
  - **Build number**.

To determine the device serial number, touch **About phone > Status**.

- **Serial number**

---

## Chapter Descriptions

Topics covered in this guide are as follows:

- [Getting Started](#), provides information on getting the mobile computer up and running for the first time.
- [Accessories](#), describes the accessories available for the mobile computer and how to use the accessories with the mobile computer.
- [USB Communication](#), explains how to perform Bluetooth functionality on the mobile computer.
- [DataWedge](#), describes how to use and configure the DataWedge application.
- [Settings](#), provides the settings for configuring the TC8300.
- [Application Deployment](#), provides information for developing and managing applications.
- [Maintenance and Troubleshooting](#), includes instructions on cleaning and storing the mobile computer, and provides troubleshooting solutions for potential problems during TC8300 operation.
- [Specifications](#), includes a table listing the technical specifications for the TC8300.

## Notational Conventions

The following conventions are used in this document:

- **Bold** text is used to highlight the following:
  - Dialog box, window and screen names
  - Drop-down list and list box names
  - Check box and radio button names
  - Icons on a screen
  - Key names on a keypad
  - Button names on a screen.
- Bullets (•) indicate:
  - Action items
  - Lists of alternatives
  - Lists of required steps that are not necessarily sequential.
- Sequential lists (for example, those that describe step-by-step procedures) appear as numbered lists.

---

## Related Documents and Software

The following documents provide more information about the TC8300.

- TC8300 Quick Start Guide, p/n MN-003365-xx
- TC8300 Regulatory Guide, p/n MN-003364-xx
- TC8300 Accessory Regulatory Guide, p/n MN002282Axx
- TC8300 User Guide for Android Version 8.1, p/n MN-003402-xx
- Rack/Wall Mount Bracket Installation Guide, p/n MN002412Axx
- Desk Mount Installation Guide, p/n MN002413Axx
- Hand Strap Installation Guide, p/n MN002417Axx

For the latest version of this guide and all guides, go to: <http://www.zebra.com/support>.

## Service Information

If you have a problem with your equipment, contact Customer Support for your region. Contact information is available at: [www.zebra.com/support](http://www.zebra.com/support).

When contacting support, please have the following information available:

- Serial number of the unit (found on manufacturing label)
- Model number or product name (found on manufacturing label)
- Software type and version number

Customer Support responds to calls by email or telephone within the time limits set forth in support agreements.

If the problem cannot be solved by Customer Support, you may need to return the equipment for servicing and will be given specific directions. We are not responsible for any damages incurred during shipment if the approved shipping container is not used. Shipping the units improperly can possibly void the warranty. Remove the microSD card from the device before shipping for service.

If the device was purchased from a business partner, contact that business partner for support.

---

## Provide Documentation Feedback

If you have comments, questions, or suggestions about this guide, send an email to [EVM-Techdocs@zebra.com](mailto:EVM-Techdocs@zebra.com).

# Getting Started

## Introduction

This chapter describes the features of the TC8300 and explains how to install and charge the battery and how to reset the TC8300.

## Unpacking

Carefully remove all protective material from the TC8300 and save the shipping container for later storage and shipping.

Verify that box contains all the equipment listed below:

- TC8300
- Battery
- Regulatory Guide.

Inspect the equipment for damage. If you are missing any equipment or if you find any damaged equipment, contact Support immediately. See [Service Information on page 14](#) for contact information.

## Removing the Screen Protection Film

A screen protection film is applied to the TC8300 screen to protect the screen during shipping. To remove the screen protector, carefully lift the thin film off the display.



## Features

Figure 1 Front View

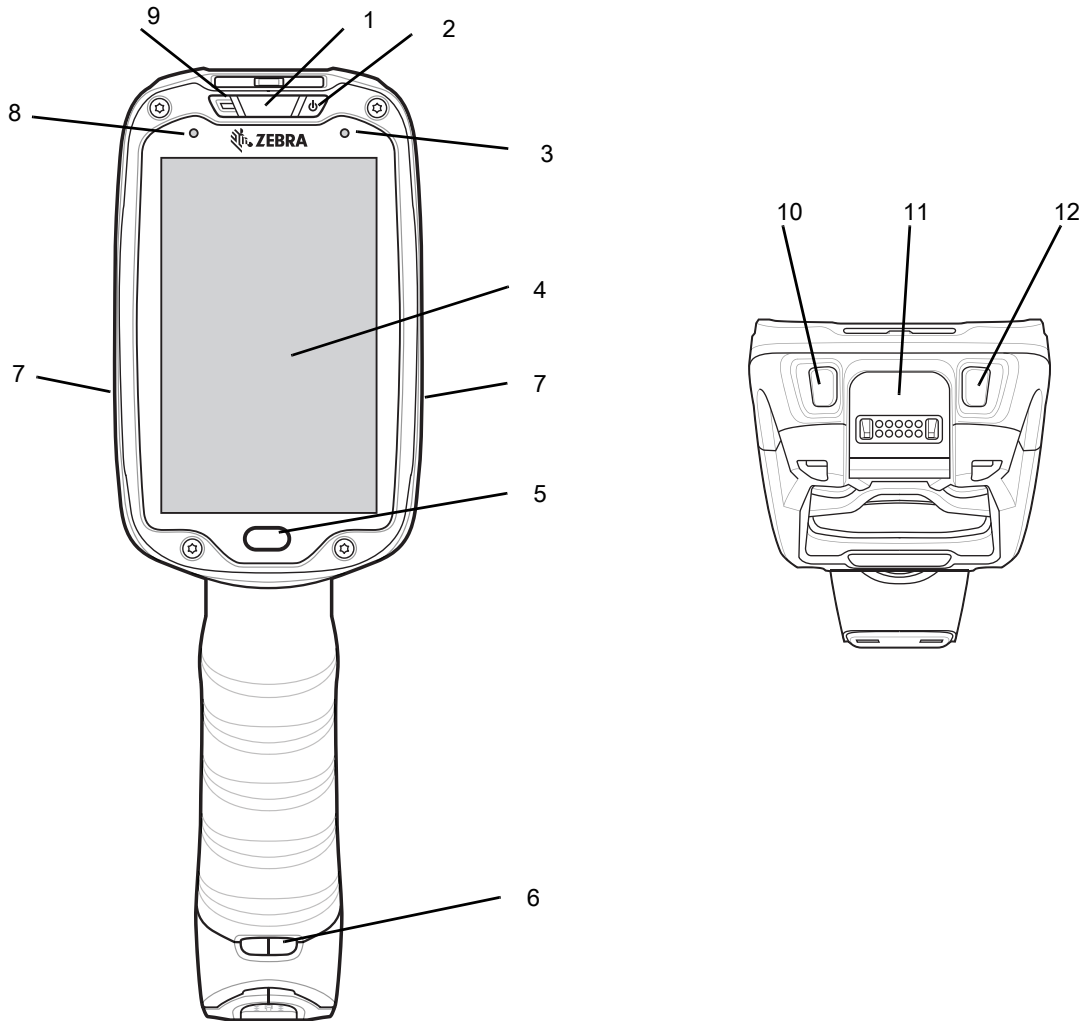


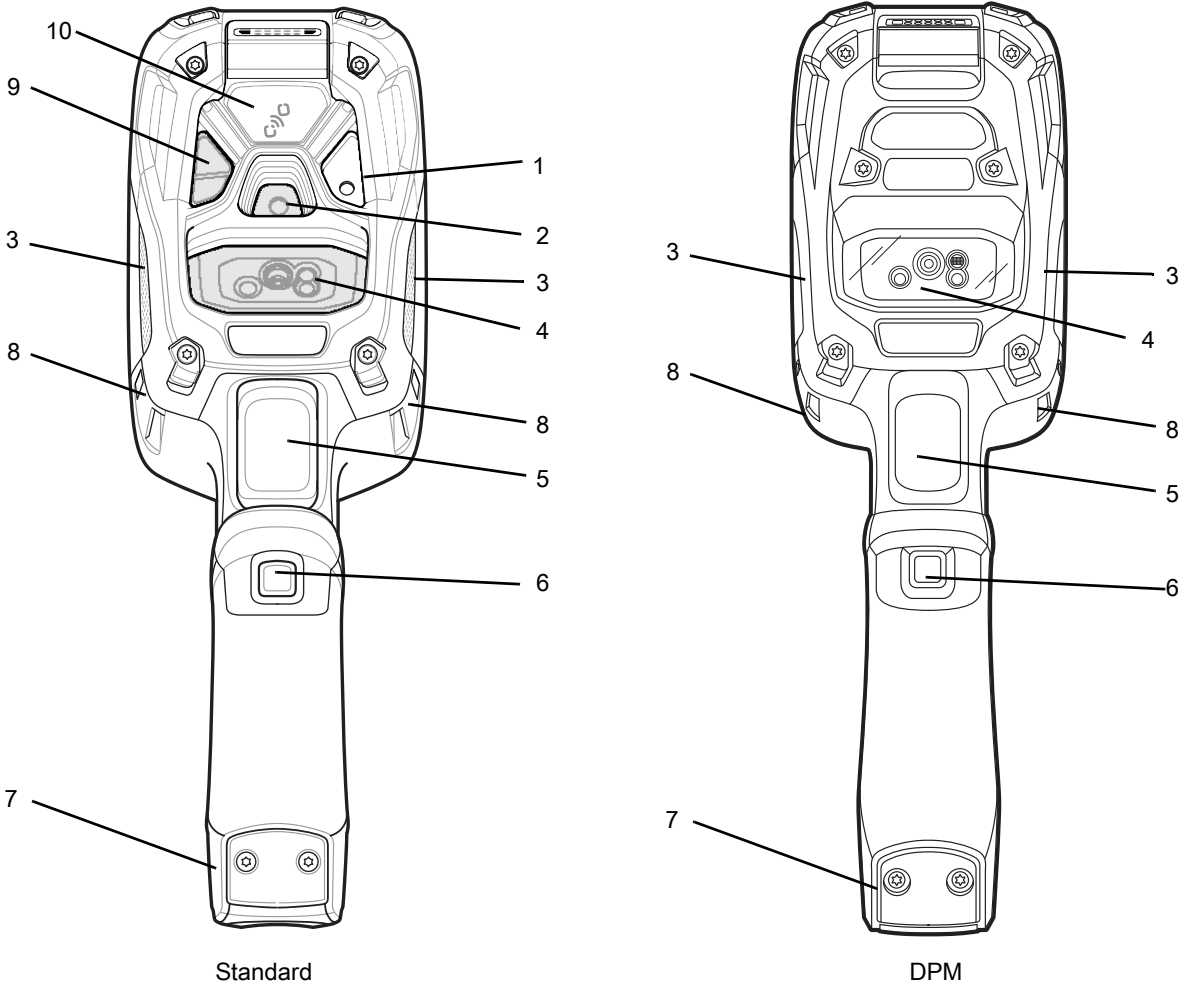
Table 1 Front View Descriptions

Number	Item	Function
1	Charging/Scan LED	Indicates battery charging status while charging, good decode indication during data capture and application generated notifications.
2	Power Button	Turns the display on and off. Press and hold to reset the device and power off.
3	Blue Indication LED	User programmable LED.
4	Display	Displays all information needed to operate the TC8300.
5	Touch Button	Press to select items.
6	Hand Strap Mounting Point	Use for installing the optional hand strap.
7	Speakers	Provides audio output for video and music playback.

**Table 1** Front View Descriptions (Continued)

Number	Item	Function
8	Ambient Light Sensor	Determines ambient light for controlling display backlight intensity (optional).
9	Microphone	Use for communication in Headset mode.
10	Volume Up Button	Increases audio volume (programmable).
11	Interface Connector	Provides USB host and client communication, audio and device charging via cables and accessories.
12	Volume Down Button	Decreases audio volume (programmable).

**Figure 2** Back View



**Table 2** Back View Descriptions

Number	Item	Function
1	Camera Flash	Provides illumination for the camera (optional).
2	Camera	Takes photos and videos (optional).
3	Speaker	Provides audio output.
4	Scanner	Provides data capture using the imager or laser scanner.
5	Trigger	Initiates data capture (programmable).
6	Push-To-Talk (PTT) Button	Initiates Push-To-Talk communication (programmable).
7	Battery Pack	Provides power to the device.
8	Hand Strap Mounting Point	Use for installing the optional hand strap.
9	Proximity Sensor	Long range proximity sensor (optional).

## Setup

Perform these procedures to start using the TC8300 for the first time.

1. Install a micro secure digital (SD) card (optional).
2. Install the battery.
3. Charge the TC8300.
4. Power on the TC8300.

## Installing the microSD Card

The microSD card slot provides secondary non-volatile storage. The slot is located under the back bezel of the unit. Refer to the documentation provided with the card for more information, and follow the manufacturer's recommendations for use.



**WARNING:** Follow proper electrostatic discharge (ESD) precautions to avoid damaging the microSD card. Proper ESD precautions include, but are not limited to, working on an ESD mat and ensuring that the operator is properly grounded.

Remove back bezel only in a dry location.

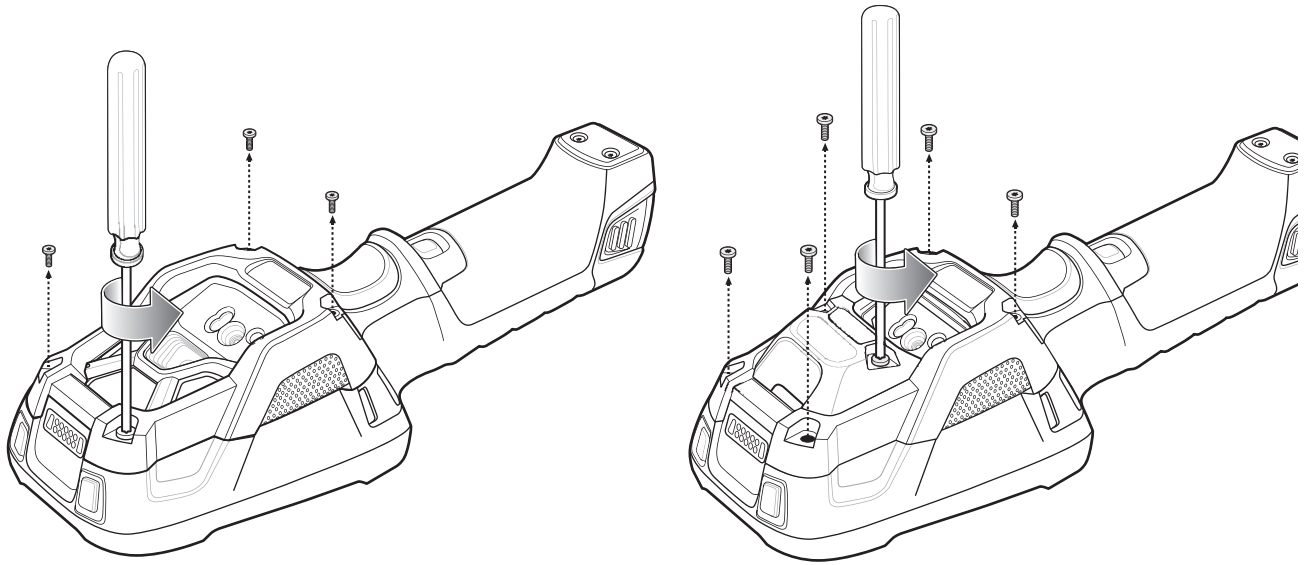


**NOTE:** The Condensation Resistant configuration has six screws securing the back bezel.

When installing a microSD card on Condensation Resistant configurations, replace the Back Bezel with desiccant pack. See [Condensation Resistant Rear Bezel Replacement on page 71](#). Once the Rear Bezel is removed, the desiccant pack absorbs ambient moisture and can lessen the life of the desiccant pack.

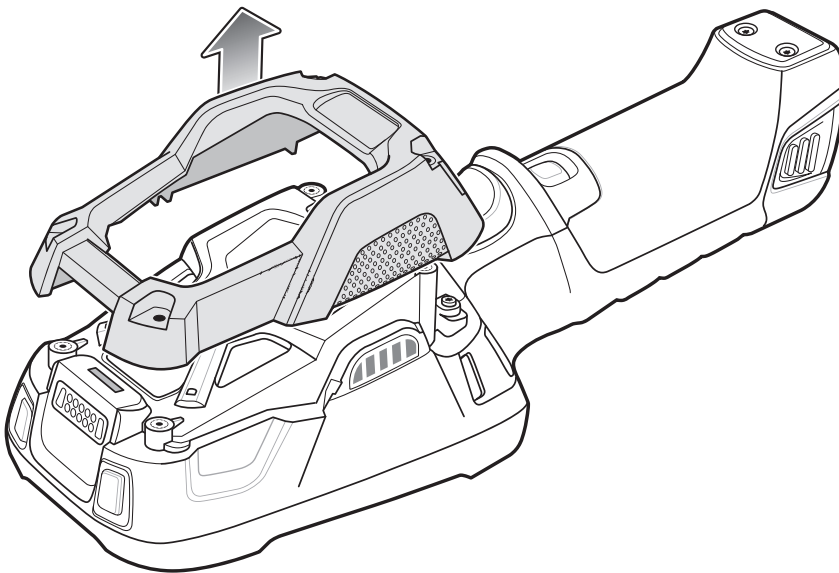
1. Remove the Torx T8 screws holding the back bezel in place.

**Figure 3** Remove Screws



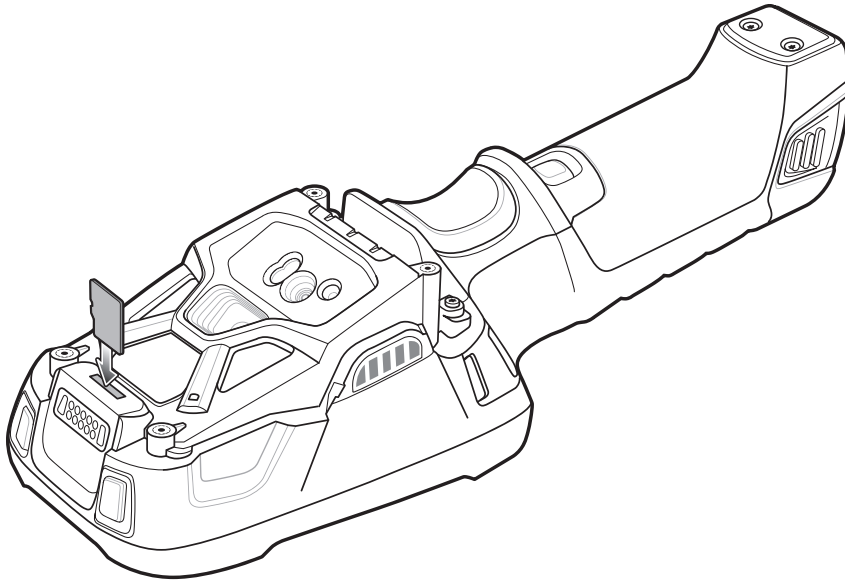
2. Lift the bezel to expose the SD slot.

**Figure 4** Remove Bezel



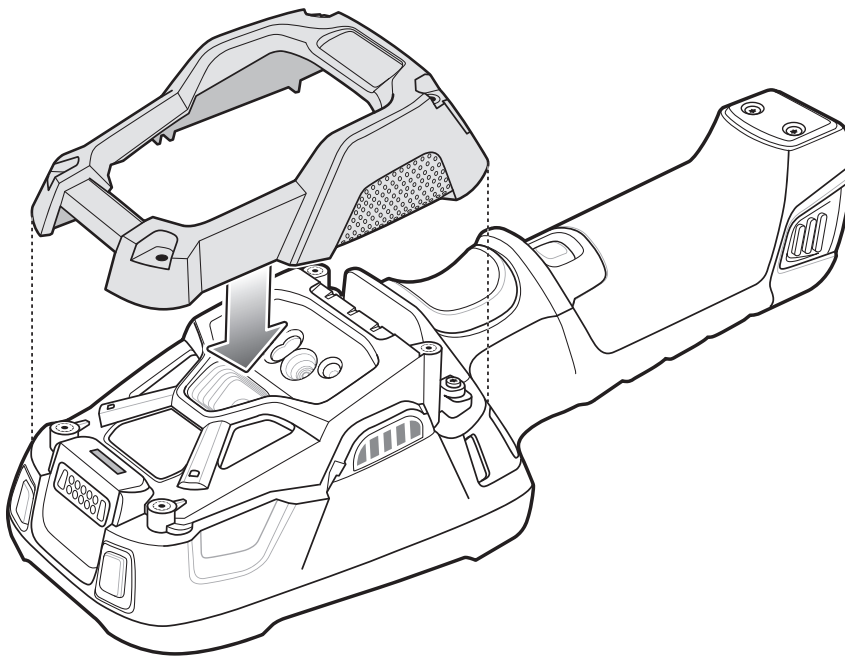
3. Insert the microSD card into the slot with contacts facing the bottom of the device.

**Figure 5** Insert microSD Card



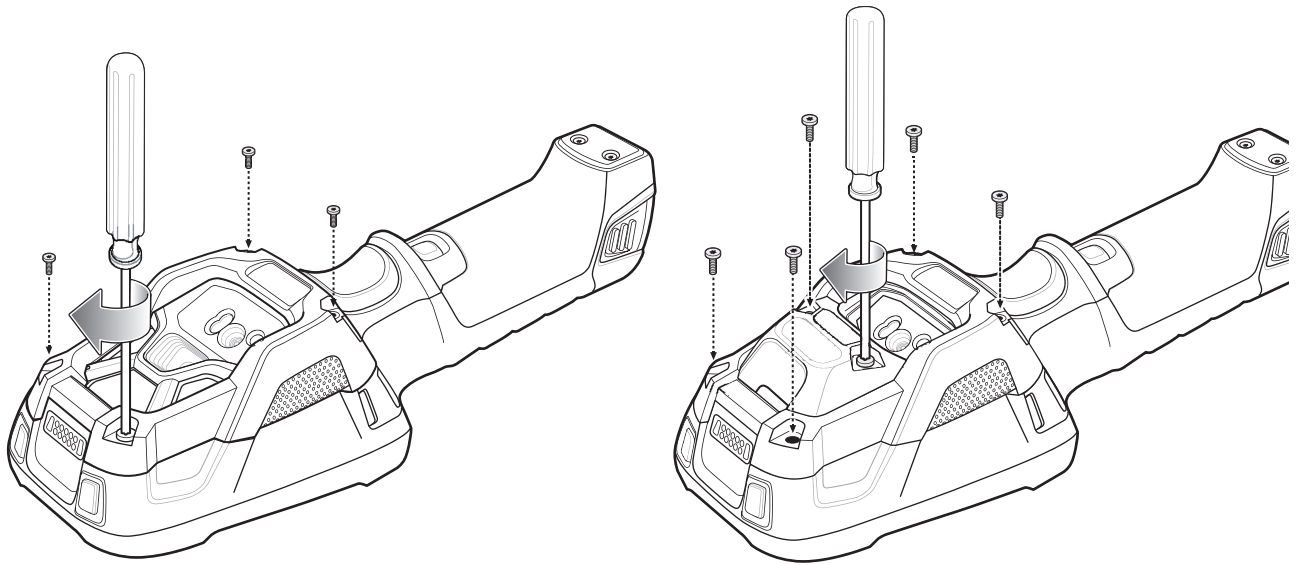
5. Align the back bezel onto the device.

**Figure 6** Align Back Bezel



4. Tighten the four screws using T8 hex screwdriver.
5. Torque to 4.5 kg-cm.

**Figure 7** Secure Bezel



## Installing the Battery

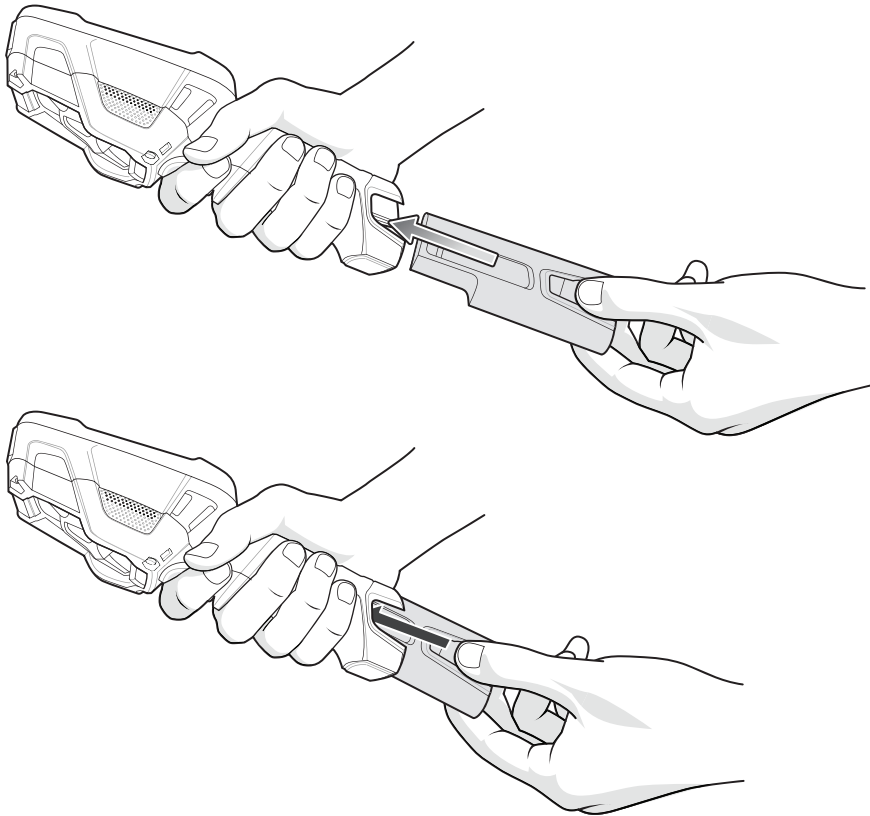
To install the battery:



**NOTE:** The battery is keyed to ensure that the battery is inserted properly. The notch in the battery must face the back of the device.

1. Align the battery with the notch facing the back of the device.
2. Slide the battery into the handle of the device.

**Figure 8** Battery Installation



3. Snap battery into place.

## Charging the Battery

Before using the TC8300 for the first time, charge the battery using a cable or a cradle with the appropriate power supply. For information about the accessories available for the TC8300, see [Accessories](#).

The TC8300 is equipped with a supercapacitor (supercap) which automatically charges from the fully-charged main battery. The supercap requires approximately 10 minutes to fully charge. The supercap retains random access memory (RAM) data in memory and WLAN connection for at least 30 seconds when the main battery is removed during Hot Swap. After 30 seconds, the WLAN connection is dropped and the RAM data is retained for 20 minutes.

- 4-Slot Battery Charger
- 2-Slot USB Charge Cradle
- 5-Slot Charge Only Cradle
- 5-Slot Ethernet Cradle
- 5-Slot Charge Only Cradle with 4-Slot Battery Charger
- 5-Slot Charge Only Cradle with 4-Slot Battery Charger.

The 6,700 mAh battery charges from 0 - 90% in less than four hours at room temperature.

The 7,000 mAh battery charges from 0 - 90% in less than five hours at room temperature.

Charge batteries in temperatures from 0 °C to 40 °C (32 °F to 104 °F). The device or accessory always performs battery charging in a safe and intelligent manner. At higher temperatures (e.g. approximately +37 °C

(+98 °F)) the device or accessory may for small periods of time alternately enable and disable battery charging to keep the battery at acceptable temperatures. The device or accessory indicates when charging is disabled due to abnormal temperatures via its LED.

1. To charge the main battery, connect the charging accessory to the appropriate power source.
2. Insert the TC8300 into a cradle or attach to a cable. The device turns on and begins charging. The Charging/Notification LED blinks amber while charging, then turns solid green when fully charged.

**Table 3** Charging/Scan LED Charging Indicators

State	Indication
Off	TC8300 is not charging. TC8300 is not inserted correctly in the cradle or connected to a power source. Charger/cradle is not powered.
Solid Amber	Healthy battery is charging.
Solid Green	Healthy battery charging is complete.
Fast Blinking Red (2 blinks/second)	Charging error, e.g.: - Temperature is too low or too high. - Charging has gone on too long without completion (typically eight hours).
Solid Red	Unhealthy battery is charging or fully charged.



**IMPORTANT:** .When trying to power on the device, a quick blink of the charging LED indicates that it does not have enough battery power to turn on. You will need to charge the battery or replace it.

## Powering on the Device

The device starts automatically as soon as power is applied; either with a charged battery installed or when inserted into the cradle.

If a charged battery is installed and the device is turned off, press the Power button to turn on.

When the device is powered on for the first time, it initializes its system. The splash screen appears for a short period of time.

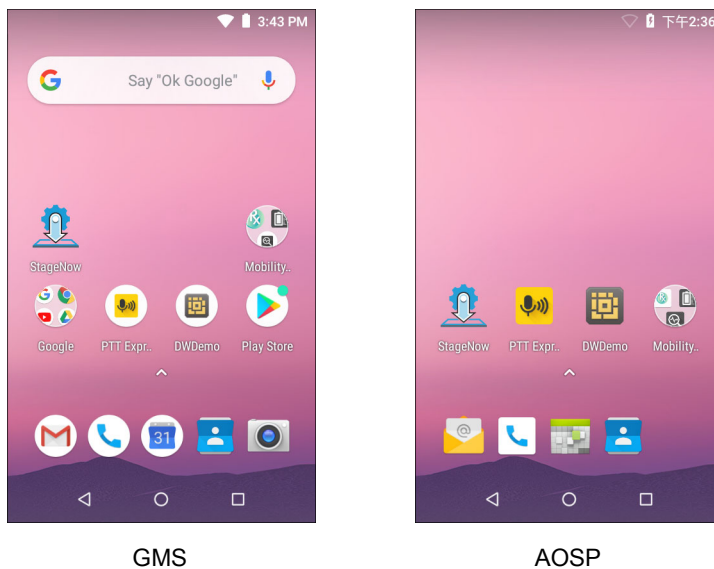
**Figure 9** Splash Screen





The splash screen is followed by the boot animation screen and then the **Home Screen**.

**Figure 10** Home Screen



## Resetting the TC8300

There are four reset functions:

- Soft reset
- Hard reset
- Enterprise reset
- Factory reset.

### Performing a Soft Reset

Perform a soft reset if applications stop responding.

1. Press the power button until the menu appears.
2. Touch **Restart**.
3. The device reboots.

### Performing a Hard Reset



**CAUTION:** Perform a hard reset only if the TC8300 stops responding.

To perform a hard reset, simultaneously press and hold the power button, trigger and PTT button for five seconds. When the device reboots, release the buttons and trigger.

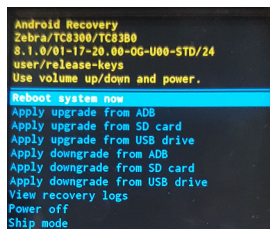
## Performing an Enterprise Reset

An Enterprise Reset erases all data in the `/cache` and `/data` partitions and clears all device settings, except those in the `/enterprise` partition.

Before performing an Enterprise Reset, copy all applications and the key remap configuration file that you want to persist after the reset into the `/enterprise/usr/persist` folder.

1. Download the Enterprise Reset file from the Zebra Support & Downloads web site.
2. Copy the Enterprise Reset zip file to the root of the microSD card. See [USB Communication](#).
3. Press and hold the Power button until the menu appears.
4. Touch **Power off**.  
The device turns off.
5. Press and release the Power button. Then press and hold the Power button and the Scan trigger.
6. When the Zebra splash screen appears, release the button and trigger.  
The System Recovery Screen appears.

**Figure 11** System Recovery Screen



7. Press the Up and Down Volume buttons to navigate to the **apply update from SD card** option.
8. Press the Power button.
9. Press the Up and Down Volume buttons to navigate to the Enterprise Reset zip file.
10. Press the Power button.  
The Enterprise Reset occurs and then the device resets.

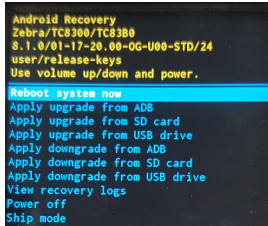
## Performing a Factory Reset

A Factory Reset erases all data in the `/cache`, `/data` and `/enterprise` partitions in internal storage and clears all device settings. A Factory Reset returns the device to the last installed operating system image. To revert to a previous operating system version, re-install that operating system image. See [System Update on page 160](#) for more information.

1. Download the Factory Reset file from the Zebra Support & Downloads web site.
2. Copy the Factory Reset zip file to the root of the microSD card. See [USB Communication](#).
3. Press and hold the Power button until the menu appears.
4. Touch **Power off**.  
The device turns off.

5. Press and release the Power button. Then press and hold the Power button and the Scan trigger.
6. When the Zebra splash screen appears, release the button and trigger.  
The System Recovery Screen appears.

**Figure 12** System Recovery Screen



7. Press the Up and Down volume buttons to navigate to the **apply update from SD card** option.
8. Press the Power button.
9. Press the Up and Down Volume buttons to navigate to the Factory Reset zip file.
10. Press the Power button.

The Factory Reset occurs and then the device resets.

# Accessories

## Introduction

The TC8300 accessories provide a variety of product support capabilities.

**Table 4** *Accessories*

Accessory	Part Number	Description
Cradles		
2-Slot USB Charge Cradle	CRD-TC8X-2SUCHG-01	Provides device and spare battery charging and USB communication with a host computer. Use with power supply, p/n PWR-BGA12V50W0WW and country specific grounded AC line cord.
2-Slot USB Charge Cradle (for DPM only)	CRD-TC8D-2SUCHG-01	Provides device and spare battery charging and USB communication with a host computer. Use with power supply, p/n PWR-BGA12V50W0WW and country specific grounded AC line cord.
5-Slot Charge Only Cradle	CRD-TC8X-5SCHG-01	Charges up to five devices. Use with power supply, p/n PWR-BGA12V108W0WW, DC line cord, p/n 50-16002-029R and country specific grounded AC line cord.
5-Slot Ethernet Cradle	CRD-TC8X-5SETH-01	Provides device charging and provides Ethernet communication for up to five devices. Use with power supply, p/n PWR-BGA12V108W0WW, DC line cord, p/n 50-16002-029R and country specific grounded AC line cord.
5-Slot Charge Only Cradle with Battery Charger	CRD-TC8X-5SC4BC-01	Charges up to four devices and four spare batteries. Use with power supply, p/n PWR-BGA12V108W0WW, DC line cord, p/n 50-16002-029R and country specific grounded AC line cord.
5-Slot Ethernet Cradle with Battery Charger	CRD-TC8X-5SE4BC-01	Provides device charging and provides Ethernet communication for up to four devices. Provides charging for four spare batteries. Use with power supply, p/n PWR-BGA12V108W0WW, DC line cord, p/n 50-16002-029R and country specific grounded AC line cord.

## Accessories

**Table 4** *Accessories (Continued)*

Accessory	Part Number	Description
<b>Batteries and Chargers</b>		
Battery	BTRY-TC8X-67MA1-01 BTRY-TC8X-67MA1-10 BTRY-TC8X-70MA1-01 BTRY-TC8X-70MA1-01	Replacement battery (single pack). Replacement battery (10-pack). Replacement battery (single pack). Replacement battery (10-pack).
4-Slot Battery Charger	SAC-TC8X-4SCHG-01	Charges up to four spare batteries. Requires power supply, p/n PWR-BGA12V50W0WW and country specific grounded AC line cord.
USB and Charging Cable	CBL-TC8X-USBCHG-01	Provides USB communication and power to the device. Requires power supply PWR-BUA5V16W0WW and country specific un-grounded AC line cord.
<b>Audio Accessories</b>		
Quick Disconnect Audio Cable	CBL-TC8X-AUDQD-01	Snaps onto the device and provides audio to a wired headset with Quick Disconnect connector.
3.5 mm Audio Cable	CBL-TC8X-AUDBJ-01	Snaps onto the device and provides audio to a wired headset with 3.5 mm plug.
<b>Mounting Brackets</b>		
2-Slot Cradle Desktop Stand	BRKT-SCRD-SSDK-01	Use for mounting a 2-Slot cradle on a desk.
5-Slot Cradle Desktop Stand	BRKT-SCRD-MSDK-01	Use for mounting a 5-Slot cradle on a desk or rack.
Rack Mount Bracket	BRKT-SCRD-SMRK-01	Use for mounting a 5-Slot cradle or four 4-Slot Battery Chargers on a rack.
Desktop Stand	MNT-TC8X-DKPH-01	Un-powered desktop presentation stand. Allows to use the device on a flat surface (i.e. desktop) for hands-free scanning.
Cart Mount	MNT-TC8X-CMKT-01	Un-powered cart mount. Allows to use the device on carts with up to 2" diameter rail/bar and allows to use the device on hands-free scanning mode. Includes RAM Mount required for installation.
Forklift Mount	MNT-TC8X-FMKT-01	Un-powered forklift mount. Allows to install the device on a roll bar or square surface of a forklift and allows to use the device on landscape or portrait mode.
Forklift Mount	MNT-TC8X-FHKT-01	Un-powered forklift mount. Allows to install the device on a roll bar or square surface of a forklift and allows to use the device on landscape or portrait mode.
<b>Carrying Solutions</b>		
Hand Strap	SG-TC8X-HDSTP-01	Replacement hand strap.
Wrist Lanyard	50-12500-006	Optional lanyard for holding the device.
Quick Draw Soft Holster	SG-TC8X-QDHLST-01	Use to hold the device. Requires the Universal Belt.
Quick Draw Soft Holster (for DPM only)	SG-TC8D-QDHLST-01	Use to hold the device. Requires the Universal Belt.

**Table 4** Accessories (Continued)

Accessory	Part Number	Description
Presentation Soft Holster	SG-TC8X-PMHLST-01	Use to hold the device and for hands-free scanning. Requires the Universal Shoulder Strap or Universal Belt.
Universal Belt	11-08062-02R	Use to hold the Quick Draw Soft Holster or the Presentation Soft Holster.
Universal Shoulder Strap	WA6010	Use to hold the Presentation Soft Holster.
<b>Power Supplies</b>		
Power Supply	PWR-BUA5V16W0WW	Provides power to the device using the USB and Charging Cable. Requires country specific un-grounded AC line cord.
Power Supply	PWR-BGA12V50W0WW	Provides power to the 2-Slot cradles and 4-Slot Spare Battery Charger. Requires country specific grounded AC line cord.
Power Supply	PWR-BGA12V108W0WW	Provides power to the 5-Slot Charge Only Cradle, 5-Slot Ethernet Cradle, 5-Slot Charge Only Cradle with Battery Charger and the 5-Slot Ethernet Cradle with Battery Charger. Requires DC Line Cord, p/n 50-16002-029R and country specific grounded AC line cord.
DC Y Cable	25-85993-01R	Provides power from the PWR-BGA12V108W0WW power supply to two 4-Slot Battery Chargers.
DC Line Cord	50-16002-029R	Provides power from the power supply to the 5-Slot Charge Only Cradle, 5-Slot Ethernet Cradle, 5-Slot Charge Only Cradle with Battery Charge and 5-Slot Ethernet Cradle with Battery Charger.
<b>Miscellaneous</b>		
Stylus	SG-TC7X-STYLUS-03	Stylus for use with the device (3-pack).
Screen Protectors	MISC-TC8X-SCRN-01	Provides additional protection for display (5-pack).
Replacement Condensation Resistant Back Housing	MISC-TC8X-DSCNT-01	Field replaceable desiccant cartridge for condensation resistant TC8300 models.

## 2-Slot USB Charge Cradle

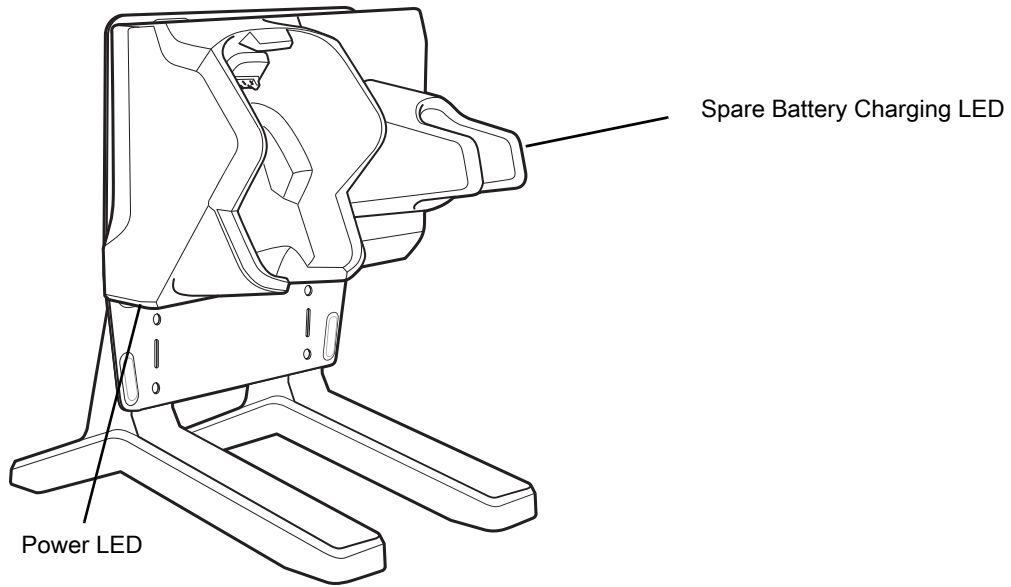


**CAUTION:** Ensure that you follow the guidelines for battery safety described in [Battery Safety Guidelines on page 167](#).

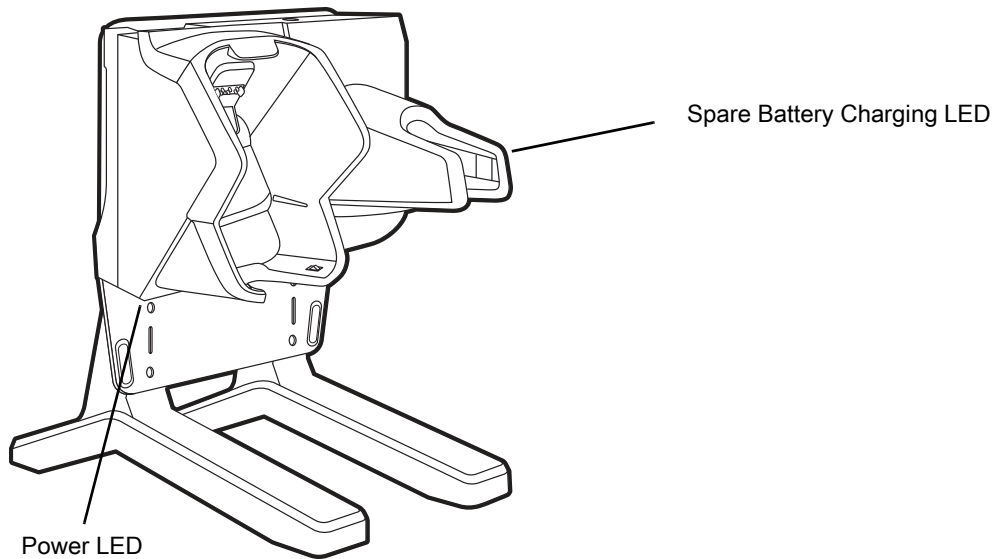
The 2-Slot USB Charge Cradle:

- Provides 5 VDC (nominal) power for operating the device.
- Provide USB communication with a host computer.
- Charges the device's battery.
- Charges a spare battery.

**Figure 13** 2-Slot Charge Only Cradle (Shown on Optional Desk Mount)



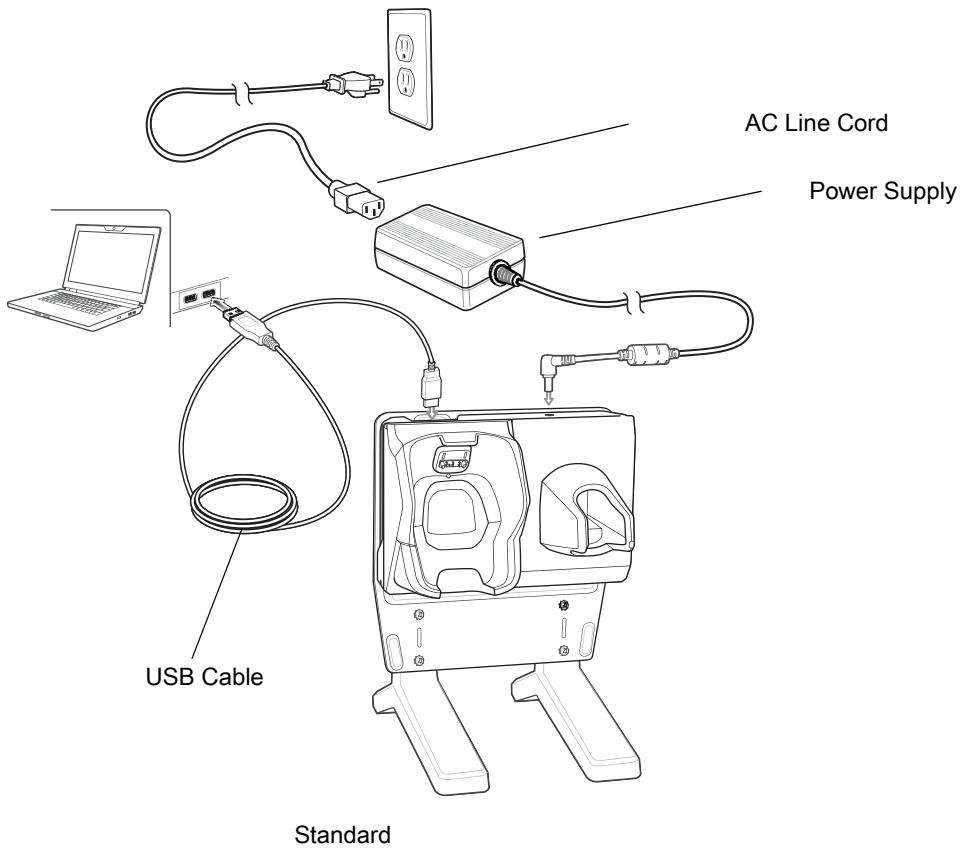
Standard



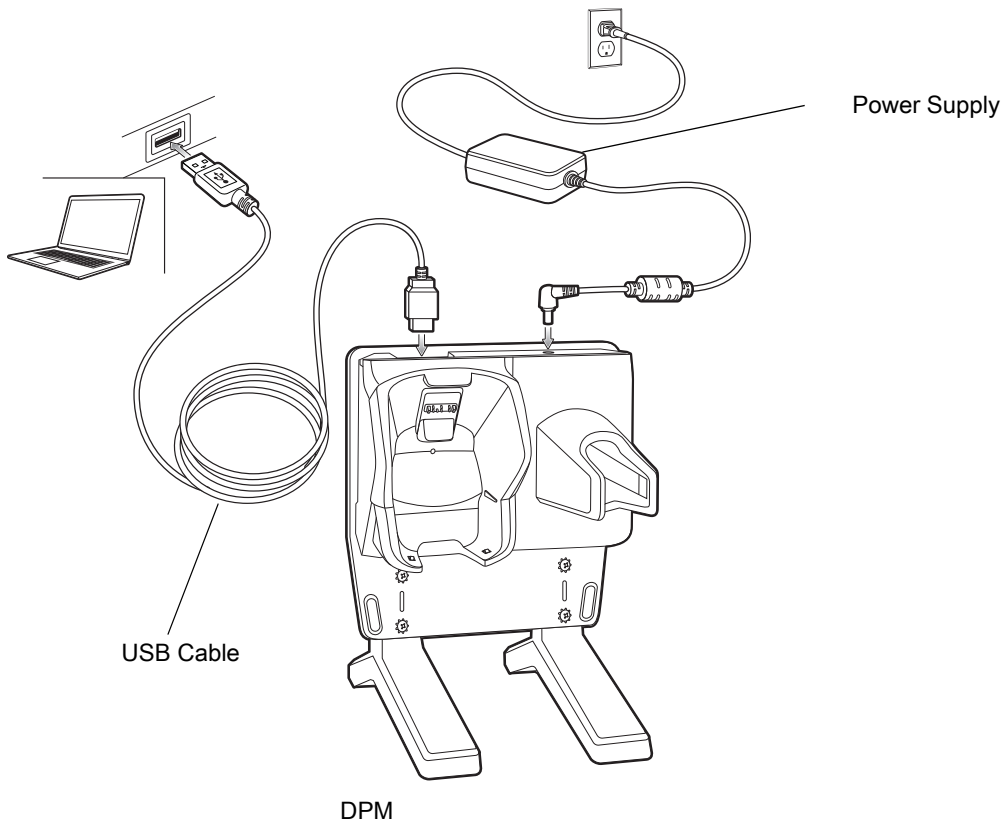
DPM

## Setup

Figure 14 Setup (Shown on Optional Desk Mount)





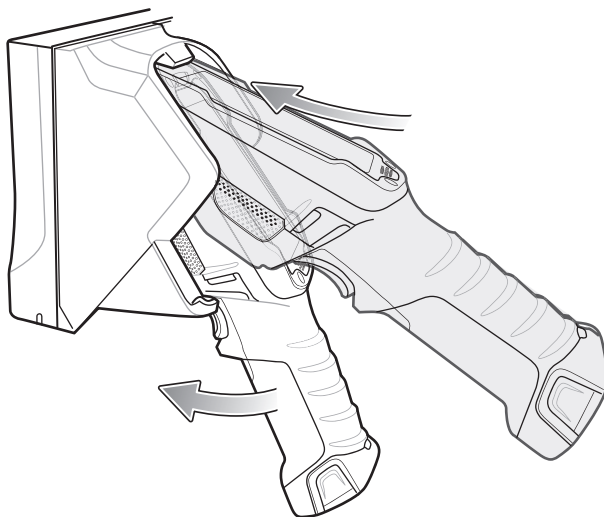


## Charging the Device

To charge a device:

1. Insert the device into the slot to begin charging.

**Figure 15** Insert Device into Cradle



2. Ensure the device is seated properly.

## Charging the Spare Battery

To charge a spare battery:

1. Insert the battery into the right slot to begin charging.
2. Ensure the battery is seated properly.

## Battery Charging

### Main Battery Charging

The device's Charging/Notification LED indicates the status of the battery charging in the device. The 6,700 mAh battery charges from 0 - 90% in less than four hours at room temperature. The 7,000 mAh battery charges from 0 - 90% in less than five hours at room temperature.

### Spare Battery Charging

The Spare battery Charging LED on the cup indicates the status of the spare battery charging. The 6,700 mAh battery charges from 0 - 90% in less than four hours at room temperature. The 7,000 mAh battery charges from 0 - 90% in less than five hours at room temperature.

**Table 5** Spare Battery Charging LED Indicators

State	Indication
Off	The battery is not charging. The battery is not inserted correctly in the cradle or connected to a power source. Cradle is not powered.
Solid Amber	Healthy battery is charging.
Solid Green	Healthy battery charging is complete.
Fast Blinking Red (2 blinks/second)	Charging error, e.g.: - Temperature is too low or too high. - Charging has gone on too long without completion (typically eight hours).
Solid Red	Unhealthy battery is charging or fully charged.

## Charging Temperature

Charge batteries in temperatures from 0 °C to 40 °C (32 °F to 104 °F). The device or cradle always performs battery charging in a safe and intelligent manner. At higher temperatures (e.g. approximately +37 °C (+98 °F)) the device or cradle may for small periods of time alternately enable and disable battery charging to keep the battery at acceptable temperatures. The device and cradle indicates when charging is disabled due to abnormal temperatures via its LED.

## 5-Slot Charge Only Cradle

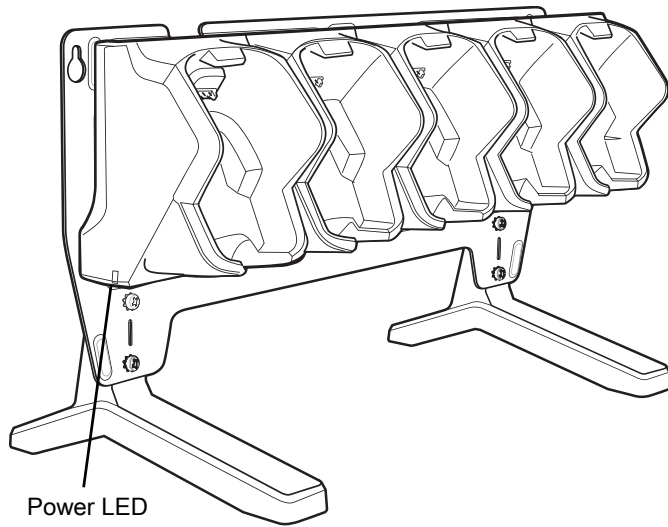


**CAUTION:** Ensure that you follow the guidelines for battery safety described in [Battery Safety Guidelines on page 167](#).

The 5-Slot Charge Only Cradle:

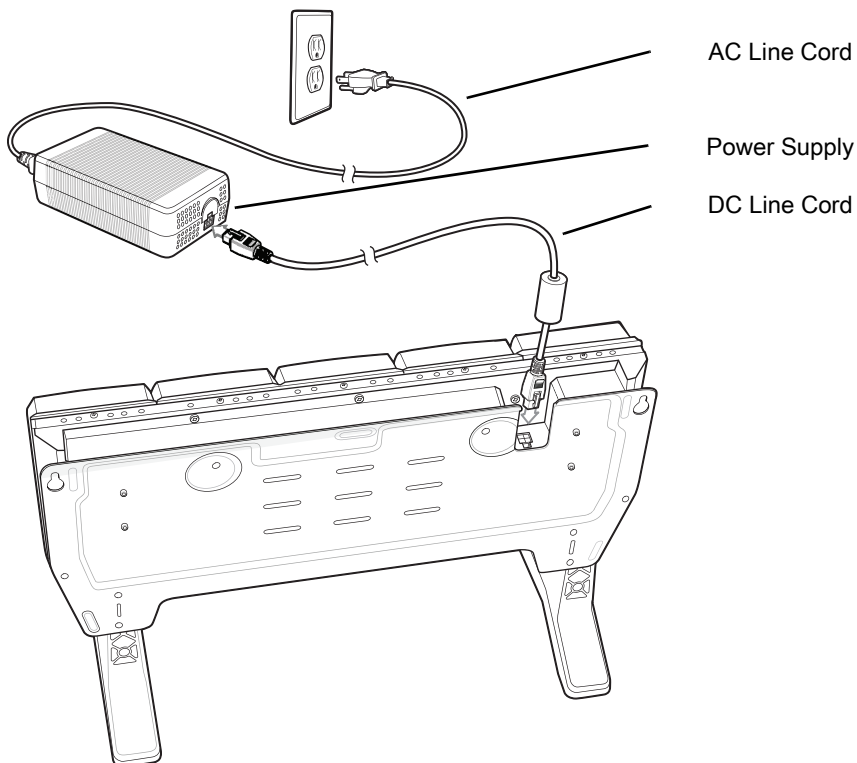
- Provides 5 VDC (nominal) power for operating the device.
- Simultaneously charges up to five devices.

**Figure 16** 5-Slot Charge Only Cradle (Shown on Optional Desk Mount)



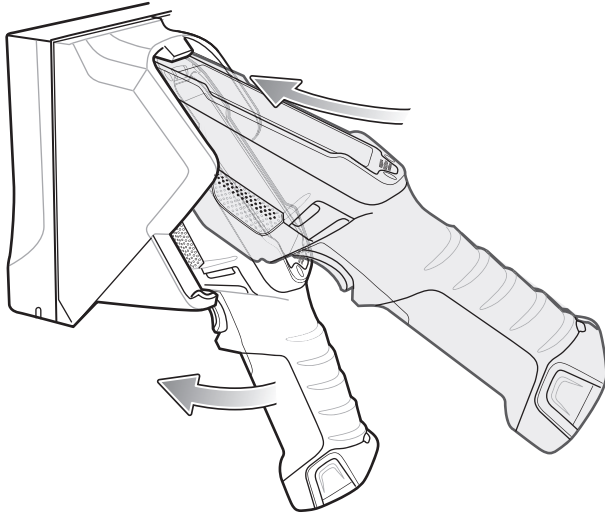
## Setup

**Figure 17** 5-Slot Charge Only Cradle Setup (Shown on Optional Desk Mount)



## Charging the Device

1. Insert the device into a slot to begin charging.

**Figure 18** Insert Device into Cradle

2. Ensure the device is seated properly.

## Battery Charging

### Main Battery Charging

The device's Charging/Notification LED indicates the status of the battery charging in the device. The 6,700 mAh battery charges from 0 - 90% in less than four hours at room temperature. The 7,000 mAh battery charges from 0 - 90% in less than five hours at room temperature.

### Charging Temperature

Charge batteries in temperatures from 0 °C to 40 °C (32 °F to 104 °F). The device always performs battery charging in a safe and intelligent manner. At higher temperatures (e.g. approximately +37 °C (+98 °F)) the device may for small periods of time alternately enable and disable battery charging to keep the battery at acceptable temperatures.

## 5-Slot Charge Only Cradle with Battery Charger

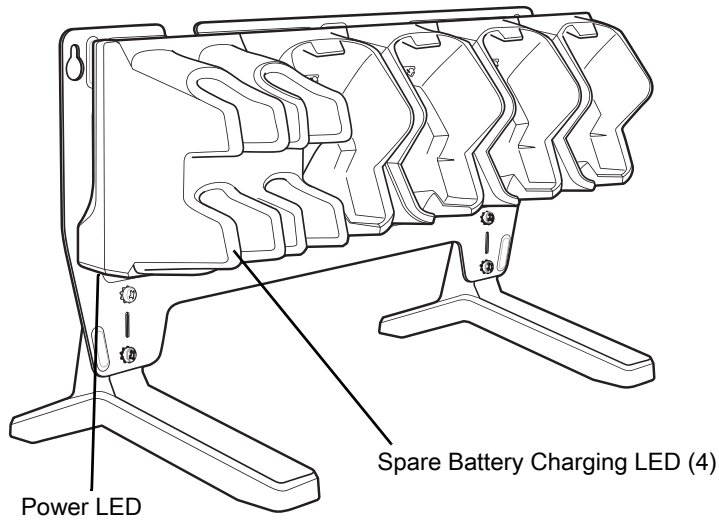


**CAUTION:** Ensure that you follow the guidelines for battery safety described in [Battery Safety Guidelines on page 167](#).

The 4-Slot Charge Only Cradle with Battery Charger:

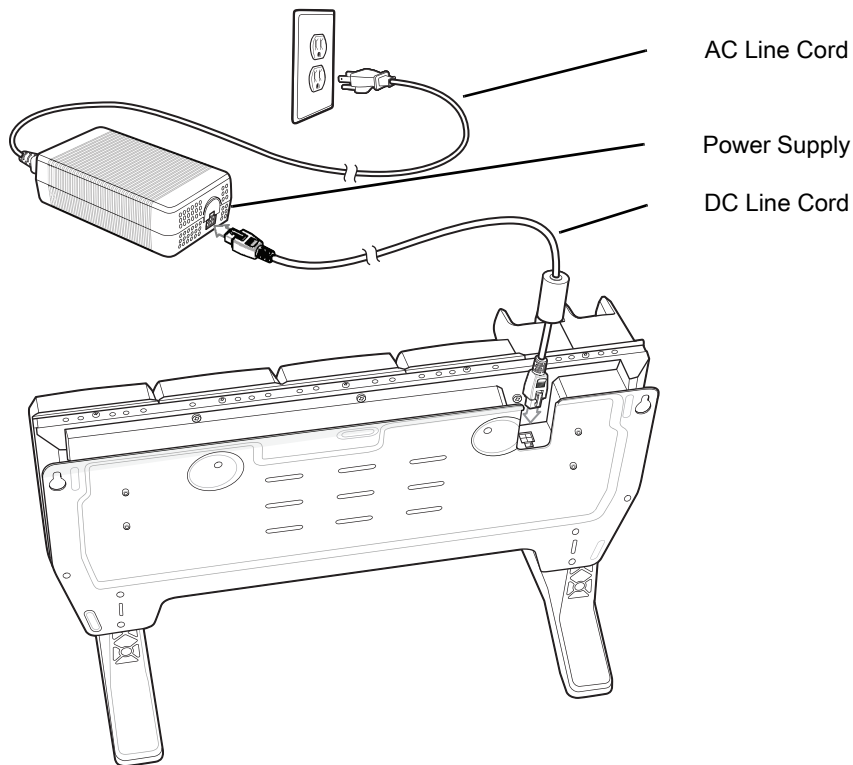
- Provides 5 VDC (nominal) power for operating the device.
- Simultaneously charges up to four devices.
- Charges up to four spare batteries.

**Figure 19** 5-Slot Charge Only Cradle with Battery Charger (Shown on Optional Desk Mount)



## Setup

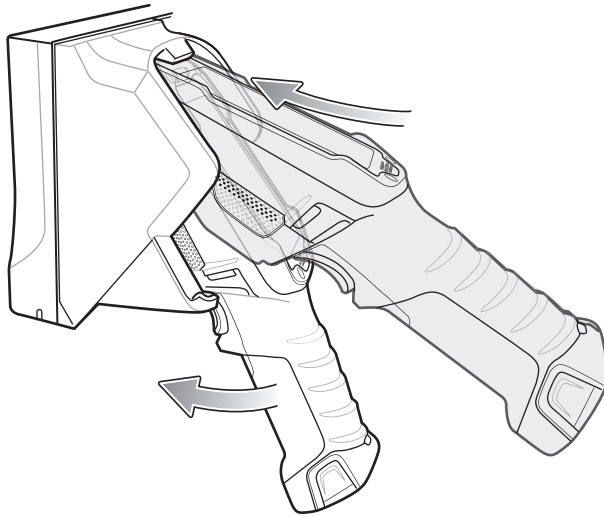
**Figure 20** 5-Slot Charge Only Cradle with Battery Charger Setup (Shown on Optional Desk Mount)



## Charging the Device

1. Insert the device into a slot to begin charging.

**Figure 21** Insert Device into Cradle



2. Ensure the device is seated properly.

## Battery Charging

### Main Battery Charging

The device's Charging/Notification LED indicates the status of the battery charging in the device. The 6,700 mAh battery charges from 0 - 90% in less than four hours at room temperature. The 7,000 mAh battery charges from 0 - 90% in less than five hours at room temperature.

### Spare Battery Charging

The Spare battery Charging LED on the cup indicates the status of the spare battery charging. The 6,700 mAh battery charges from 0 - 90% in less than four hours at room temperature. The 7,000 mAh battery charges from 0 - 90% in less than five hours at room temperature.

**Table 6** Spare Battery Charging LED Indicators

State	Indication
Off	The battery is not charging. The battery is not inserted correctly in the cradle or connected to a power source. Cradle is not powered.
Solid Amber	Healthy battery is charging.
Solid Green	Healthy battery charging is complete.
Fast Blinking Red (2 blinks/second)	Charging error, e.g.: - Temperature is too low or too high. - Charging has gone on too long without completion (typically eight hours).
Solid Red	Unhealthy battery is charging or fully charged.

### Charging Temperature

Charge batteries in temperatures from 0 °C to 40 °C (32 °F to 104 °F). The device always performs battery charging in a safe and intelligent manner. At higher temperatures (e.g. approximately +37 °C (+98 °F)) the

device may for small periods of time alternately enable and disable battery charging to keep the battery at acceptable temperatures.

## 5-Slot Ethernet Cradle

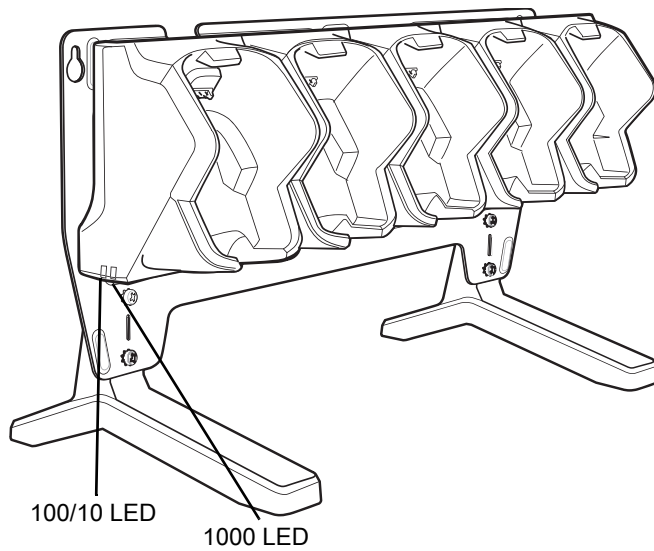


**CAUTION:** Ensure that you follow the guidelines for battery safety described in [Battery Safety Guidelines on page 167](#).

The 5-Slot Ethernet Cradle:

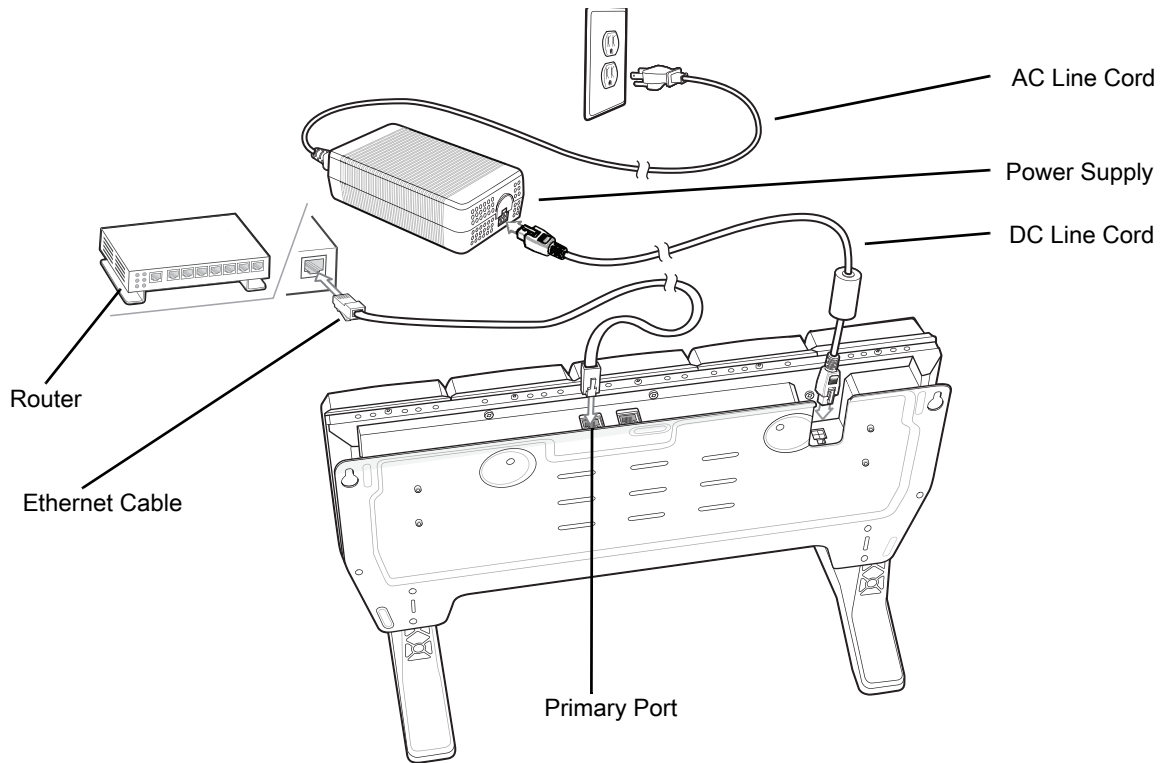
- Provides 5.0 VDC (nominal) power for operating the device.
- Connects the device (up to five) to an Ethernet network.
- Simultaneously charges up to five devices.

**Figure 22** 5-Slot Ethernet Cradle (Shown on Optional Desk Mount)



To setup the 5-Slot Ethernet cradle:

**Figure 23** 5-Slot Ethernet Cradle with Battery Charger Setup (Shown on Optional Desk Mount)



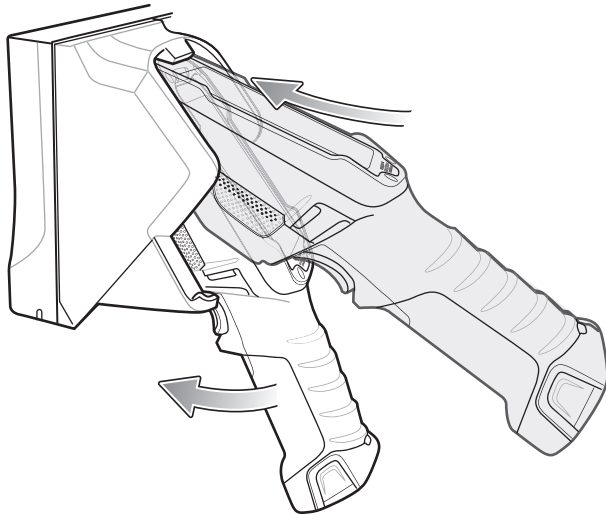
1. Connect the DC line cord to power supply.
2. Connect DC line cord to power input on cradle.
3. Connect Ethernet cable to Ethernet port 1 on cradle.
4. Connect other end of Ethernet cable to router port.
5. Connect the AC line cord to the power supply.
6. Plug the AC line cord into an AC outlet.

## Charging the Device

To charge the device:

1. Insert the device into a slot to begin charging.



**Figure 24** Insert Device into Cradle

2. Ensure the device is seated properly.

## Battery Charging

### Main Battery Charging

The device's Charging/Notification LED indicates the status of the battery charging in the device. The 6,700 mAh battery charges from 0 - 90% in less than four hours at room temperature. The 7,000 mAh battery charges from 0 - 90% in less than five hours at room temperature.

### Charging Temperature

Charge batteries in temperatures from 0 °C to 40 °C (32 °F to 104 °F). The device or cradle always performs battery charging in a safe and intelligent manner. At higher temperatures (e.g. approximately +37 °C (+98 °F)) the device or cradle may for small periods of time alternately enable and disable battery charging to keep the battery at acceptable temperatures. The device and cradle indicates when charging is disabled due to abnormal temperatures via its LED.

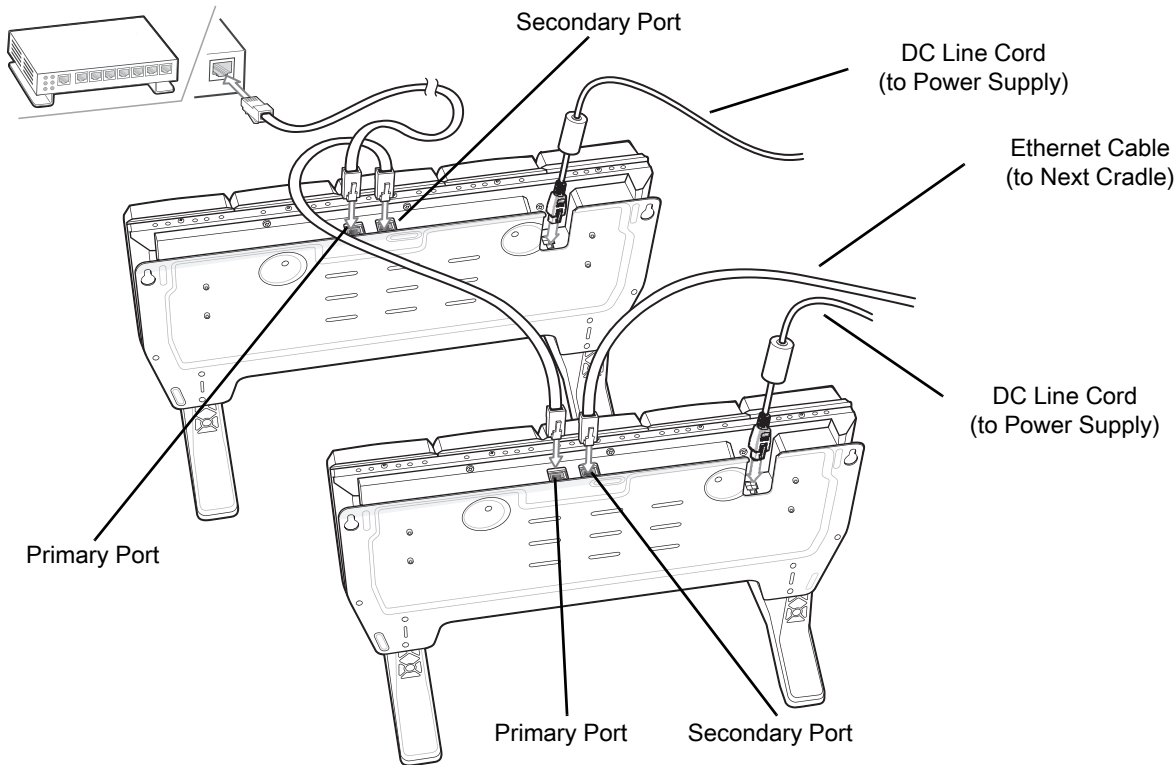
## Daisy-chaining Ethernet Cradles

Daisy-chain up to ten 5-Slot Ethernet cradles to connect several cradles to an Ethernet network. Use either a straight or crossover cable. Daisy-chaining should not be attempted when the main Ethernet connection to the first cradle is 10 Mbps as throughput issues will almost certainly result.

To daisy-chain 5-Slot Ethernet cradles:

1. Connect power to each 5-Slot Ethernet Cradle with Battery Charger.
2. Connect an Ethernet cable to port 1 on the back of the first cradle and to the Ethernet switch.
3. Connect an Ethernet cable to port 2 on the back of the first cradle to port 1 on the back of the second cradle.

**Figure 25** Daisy-Chaining 5-Slot Ethernet Cradles (Shown on Optional Desk Mount)



4. Connect additional cradles as described in step 2 and 3.

## Ethernet Settings

The following settings can be configured when using Ethernet communication:


- Proxy Settings
- Static IP.

## Configuring for a Proxy Server

A proxy server is a server that acts as an intermediary for requests from clients seeking resources from other servers. A client connects to the proxy server and requests some service, such as a file, connection, web page, or other resource, available from a different server. The proxy server evaluates the request according to its filtering rules. For example, it may filter traffic by IP address or protocol. If the request is validated by the filter, the proxy provides the resource by connecting to the relevant server and requesting the service on behalf of the client.

It is important for enterprise customers to be able to set up secure computing environments within their companies, making proxy configuration essential. Proxy configuration acts as a security barrier ensuring that the proxy server monitors all traffic between the Internet and the intranet. This is normally an integral part of security enforcement in corporate firewalls within intranets.

To configure the device for a proxy server:

1. Swipe down from the Status bar to open the Quick Access panel and then touch .
2. Touch **Network & Internet > Ethernet**.

3. Place the device into the Ethernet cradle slot.
4. Slide the switch to the **On** position.
5. Touch and hold **eth0** until the menu appears.
6. Touch **Modify proxy**.
7. Touch the **Proxy** drop-down list and select **Manual**.


**Figure 26** Ethernet Proxy Settings

<··> eth0  
 Proxy  
 Manual  
 Proxy hostname  
 proxy.example.com  
 Proxy port  
 8080  
 Bypass proxy for  
 example.com,mycomp.test.com,  
 CANCEL MODIFY

8. In the **Proxy hostname** text box, enter the address of the proxy server.
9. In the **Proxy port** text box, enter the port number for the proxy server.
10. In the **Bypass proxy for** text box, enter addresses for web sites that are not required to go through the proxy server. Use the separator “|” between addresses. Do not use spaces or carriage returns between addresses.
11. Touch **Modify**.
12. Touch .

## Configuring Ethernet Static IP Address

The device includes Ethernet cradle drivers. After inserting the device, configure Ethernet connection:

1. Swipe down from the Status bar to open the Quick Access panel and then touch .
2. Touch **Network & Internet > Ethernet**.
3. Place the device into the Ethernet cradle slot.
4. Slide the switch to the **On** position.
5. Touch **Eth0**.
6. Touch **Disconnect**.
7. Touch **Eth0**.
8. Touch and hold the IP Settings drop-down list and select **Static**.

**Figure 27** Static IP Settings



9. In the **IP address** field, enter the proxy server address.
10. If required, in the **Gateway** text box, enter a gateway address for the device.
11. If required, in the **Netmask** field, enter the network mask address.
12. If required, in the **DNS address** fields, enter a Domain Name System (DNS) address.
13. Touch **Connect**.
14. Touch .


## LED Indicators

There are two green LEDs on the side of the cradle and on each Ethernet port. These green LEDs light and blink to indicate the data transfer rate.

**Table 7** LED Data Rate Indicators

Data Rate	1000 LED	100/10 LED
1 Gbps	On/Blink	Off
100 Mbps	Off	On/Blink
10 Mbps	Off	On/Blink

## Establishing Ethernet Connection

1. Swipe down from the status bar to open the quick access panel and then touch  > **Network & Internet** > **Ethernet**.
2. Slide the Ethernet switch to the **ON** position.

3. Insert the device into a slot.
4. The <math>\leftrightarrow</math> icon appears in the Status bar.
5. Touch **Eth0** to view Ethernet connection details.

## 5-Slot Ethernet Cradle with Battery Charger

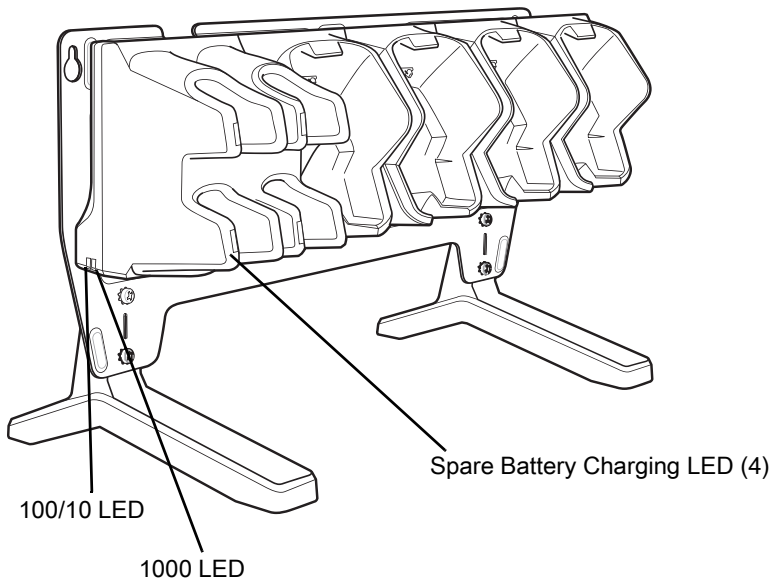


**CAUTION:** Ensure that you follow the guidelines for battery safety described in [Battery Safety Guidelines on page 167](#).

The 5-Slot Ethernet Cradle with Battery Charger:

- Provides 5.0 VDC (nominal) power for operating the device.
- Connects the device (up to five) to an Ethernet network.
- Simultaneously charges up to four devices.
- Simultaneously charges up to four spare batteries.

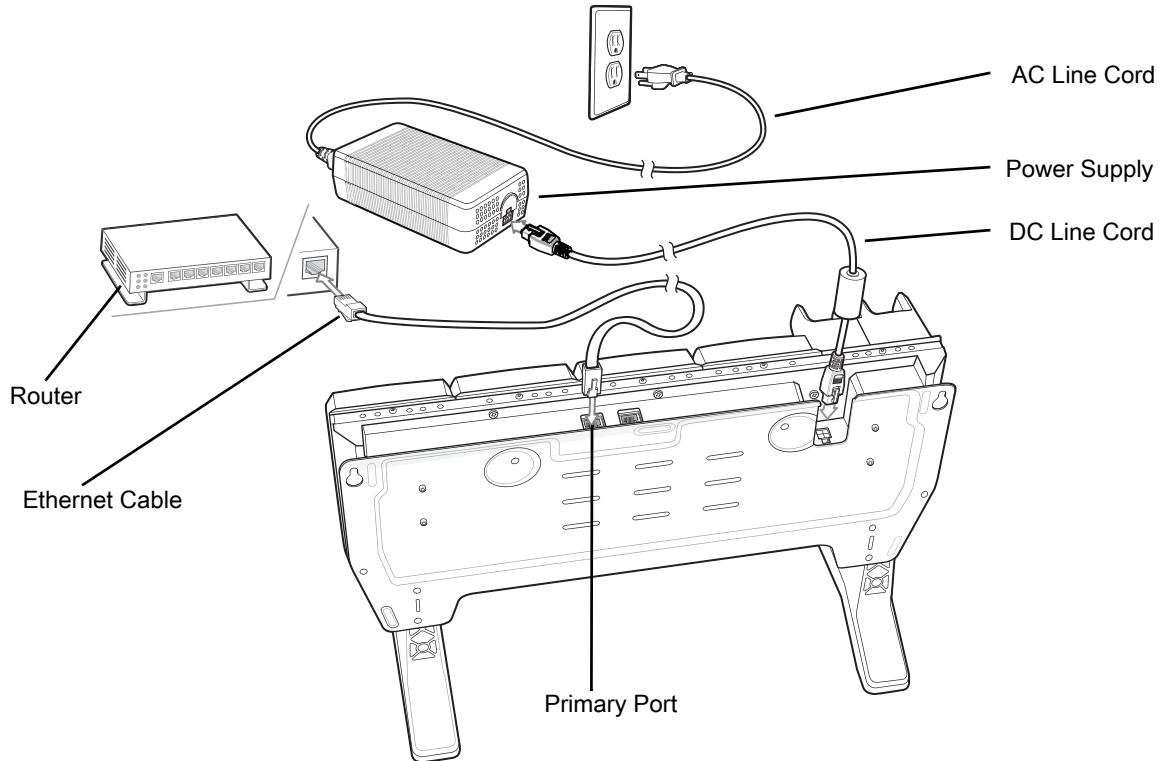
**Figure 28** 5-Slot Ethernet Cradle with Battery Charger (Shown on Optional Desk Mount)



## Setup

To setup the 5-Slot Ethernet cradle:

**Figure 29** 5-Slot Ethernet Cradle with Battery Charger Setup (Shown on Optional Desk Mount)



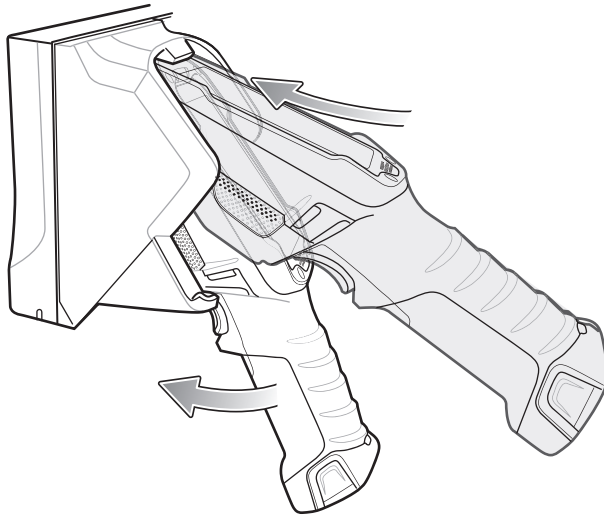
1. Connect the DC line cord to power supply.
2. Connect DC line cord to power input on cradle.
3. Connect Ethernet cable to Ethernet port 1 on cradle.
4. Connect other end of Ethernet cable to router port.
5. Connect the AC line cord to the power supply.
6. Plug the AC line cord into an AC outlet.

## Charging the Device

To charge the device:

1. Insert the device into a slot to begin charging.

**Figure 30** Insert Device into Cradle



2. Ensure the device is seated properly.

## Battery Charging

### Main Battery Charging

The device's Charging/Notification LED indicates the status of the battery charging in the device. The 6,700 mAh battery charges from 0 - 90% in less than four hours at room temperature. The 7,000 mAh battery charges from 0 - 90% in less than five hours at room temperature.

### Spare Battery Charging

The Spare battery Charging LED on the cup indicates the status of the spare battery charging. The 6,700 mAh battery charges from 0 - 90% in less than four hours at room temperature. The 7,000 mAh battery charges from 0 - 90% in less than five hours at room temperature.

**Table 8** Spare Battery Charging LED Indicators

State	Indication
Off	The battery is not charging. The battery is not inserted correctly in the cradle or connected to a power source. Cradle is not powered.
Solid Amber	Healthy battery is charging.
Solid Green	Healthy battery charging is complete.
Fast Blinking Red (2 blinks/second)	Charging error, e.g.: - Temperature is too low or too high. - Charging has gone on too long without completion (typically eight hours).
Solid Red	Unhealthy battery is charging or fully charged.

### Charging Temperature

Charge batteries in temperatures from 0 °C to 40 °C (32 °F to 104 °F). The device or cradle always performs battery charging in a safe and intelligent manner. At higher temperatures (e.g. approximately +37 °C (+98 °F)) the device or cradle may for small periods of time alternately enable and disable battery charging to keep the

battery at acceptable temperatures. The device and cradle indicates when charging is disabled due to abnormal temperatures via its LED.



## Daisy-chaining Ethernet Cradles

See [Daisy-chaining Ethernet Cradles on page 41](#).

## Ethernet Settings

See [Ethernet Settings on page 42](#).

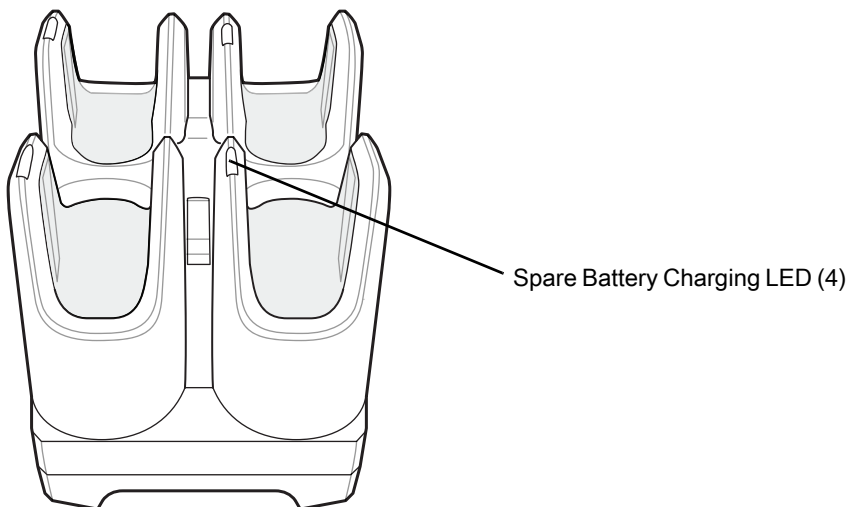
## Establishing Ethernet Connection

1. Swipe down from the status bar to open the quick access panel and then touch  > **Network & Internet** > **Ethernet**.
2. Slide the Ethernet switch to the **ON** position.
3. Insert the device into a slot.
4. The  icon appears in the Status bar.
5. Touch **Eth0** to view Ethernet connection details.

## 4-Slot Battery Charger

This section describes how to use the 4-Slot Battery Charger to charge up to four device batteries.

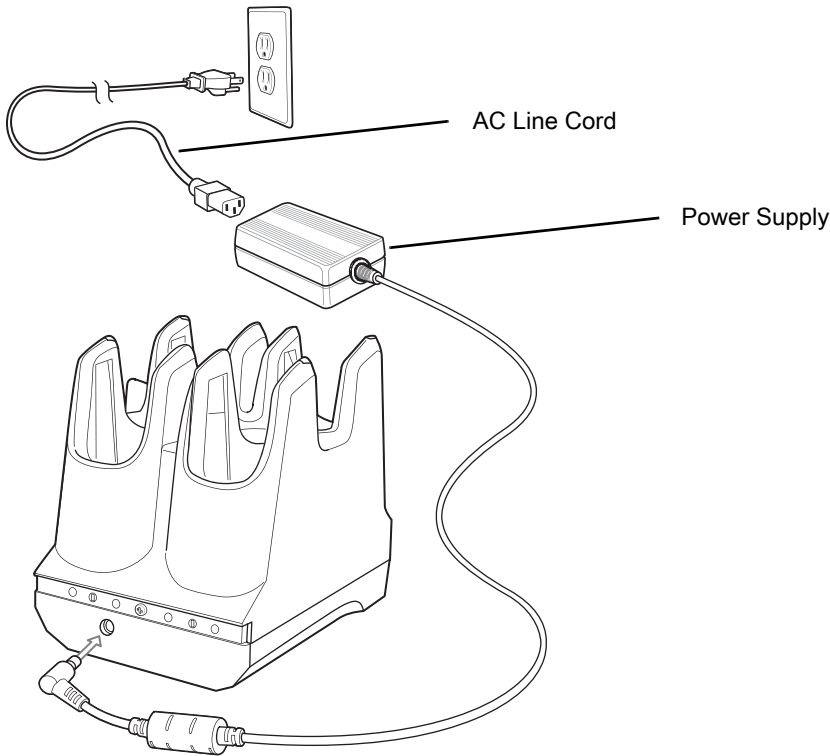
**Figure 31** 4-Slot Battery Charger





## Setup

**Figure 32** Four Slot Battery Charger Power Setup



## Charging Spare Batteries

1. Connect the charger to a power source.
2. Insert the battery into a battery charging well and gently press down on the battery to ensure proper contact.

The Spare Battery Charging LED on the cup indicates the status of the spare battery charging. The 6,700 mAh battery charges from 0 - 90% in less than four hours at room temperature. The 7,000 mAh battery charges from 0 - 90% in less than five hours at room temperature.

**Table 9** Spare Battery Charging LED Indicators

State	Indication
Off	The battery is not charging. The battery is not inserted correctly in the cradle or connected to a power source. Cradle is not powered.
Solid Amber	Healthy battery is charging.
Solid Green	Healthy battery charging is complete.
Fast Blinking Red (2 blinks/second)	Charging error, e.g.: - Temperature is too low or too high. - Charging has gone on too long without completion (typically eight hours).
Solid Red	Unhealthy battery is charging or fully charged.

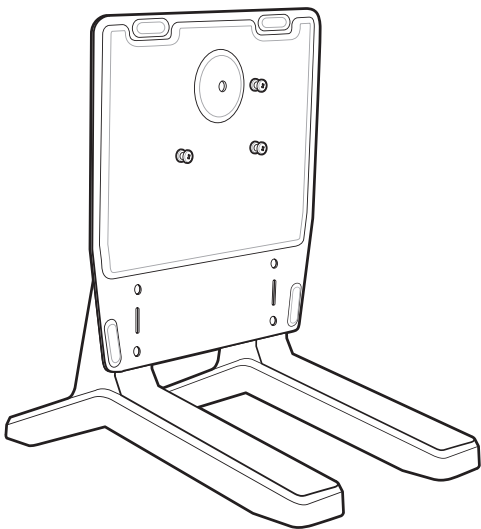
## Charging Temperature

Charge batteries in temperatures from 0 °C to 40 °C (32 °F to 104 °F). The device or cradle always performs battery charging in a safe and intelligent manner. At higher temperatures (e.g. approximately +37 °C (+98 °F)) the device or cradle may for small periods of time alternately enable and disable battery charging to keep the battery at acceptable temperatures. The device and cradle indicates when charging is disabled due to abnormal temperatures via its LED.

## 2-Slot Desk Bracket

Use the 2-Slot Desk Mount to mount the 2-Slot USB Charging cradle in a vertical position.

**Figure 33** 2-Slot Desk Mount

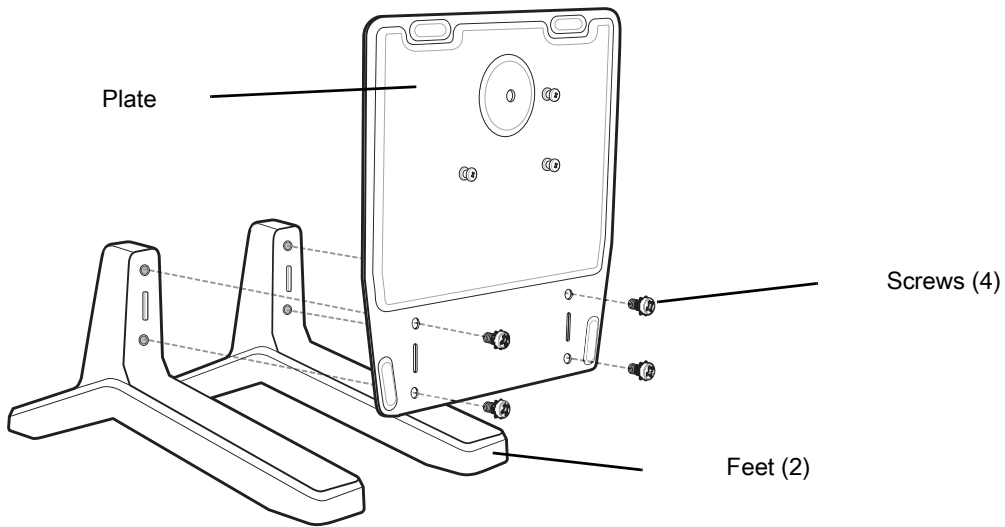


## Assembly

To assemble the 2-Slot Desk Mount:

1. Align plate mounting holes with holes in feet.

**Figure 34** Install Feet



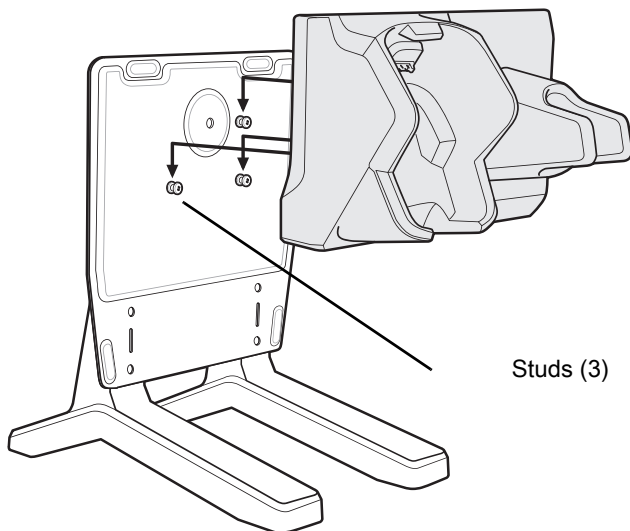
2. Secure plate to feet with four screws and four washers.

## Mounting Cradle

To mount the cradle:

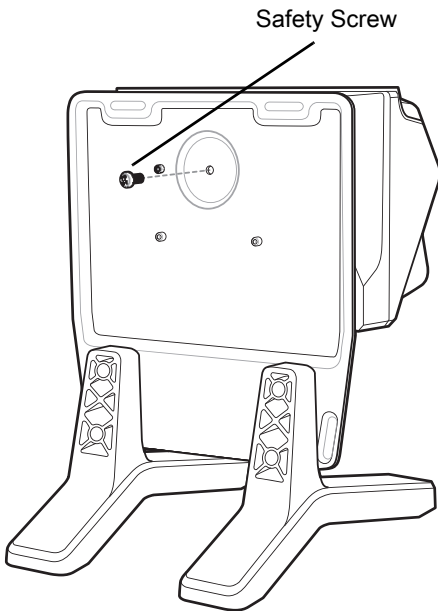
1. Align mounting slots on bottom of cradle with studs on plate.

**Figure 35** Install Cradle onto Desk Mount



2. Secure cradle to plate using safety screw.

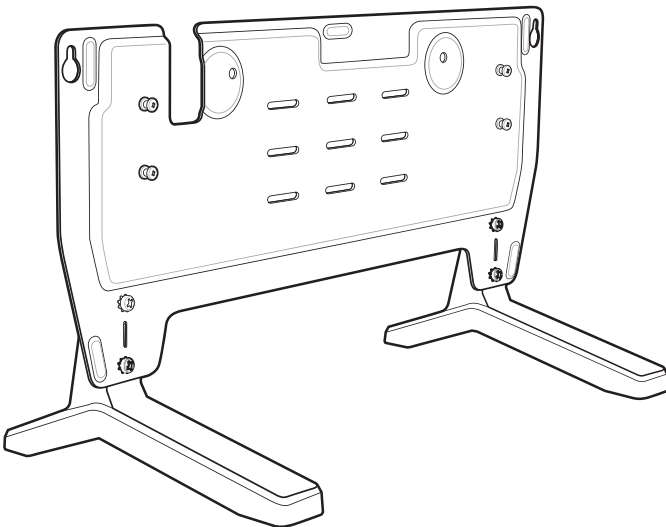
**Figure 36** Install Safety Screw



## 5-Slot Desktop Bracket

Use the 5-Slot Desk Mount to mount the 5-Slot Charge Only cradles or the 5-Slot Ethernet cradles in a vertical position.

**Figure 37** 5-Slot Desk Mount

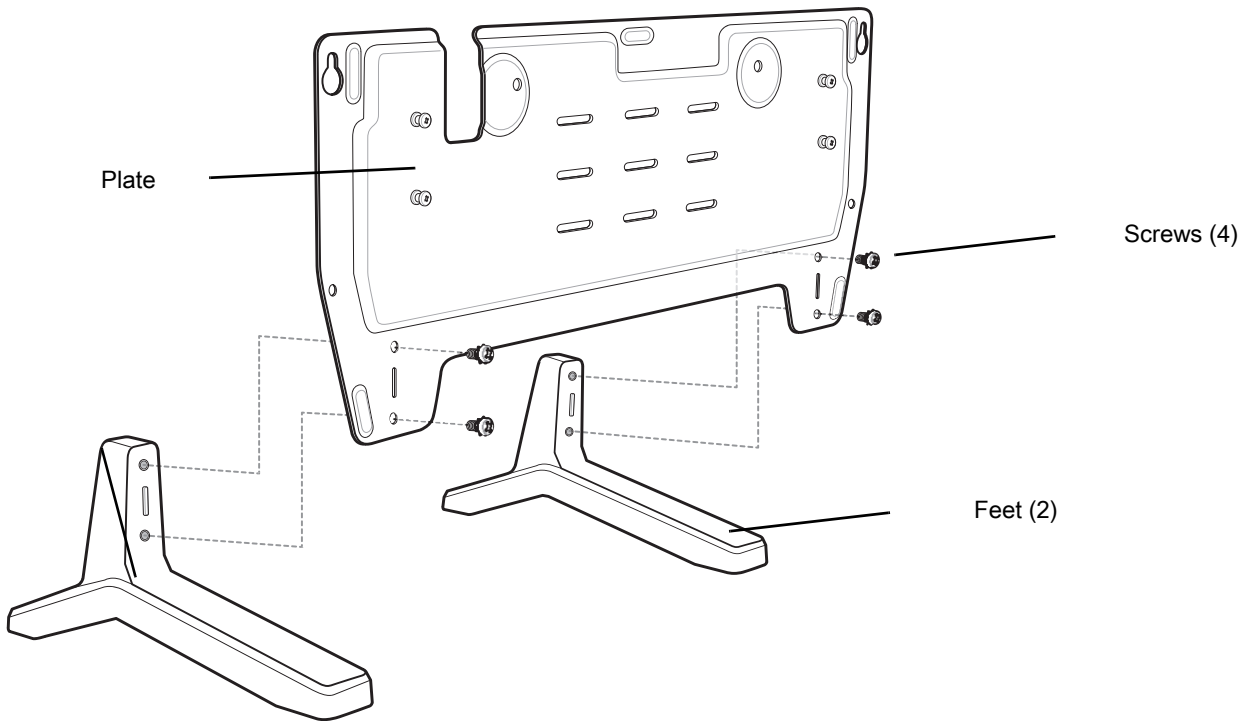


## Assembly

To assemble the 5-Slot Desk Mount:

1. Align plate mounting holes with holes in feet.

**Figure 38** Install Feet



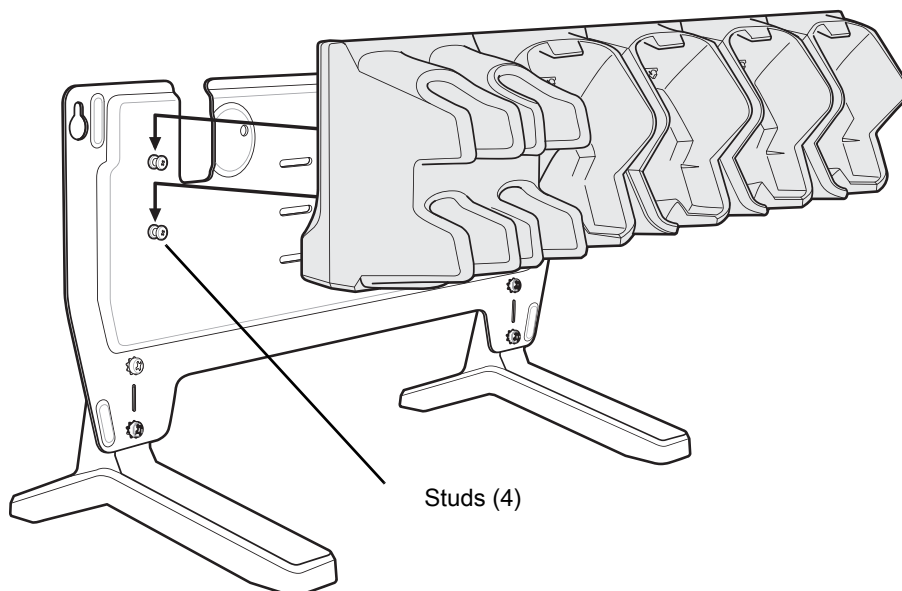
2. Secure plate to feet with four screws and four washers.

## Mount Cradle

To mount the cradle:

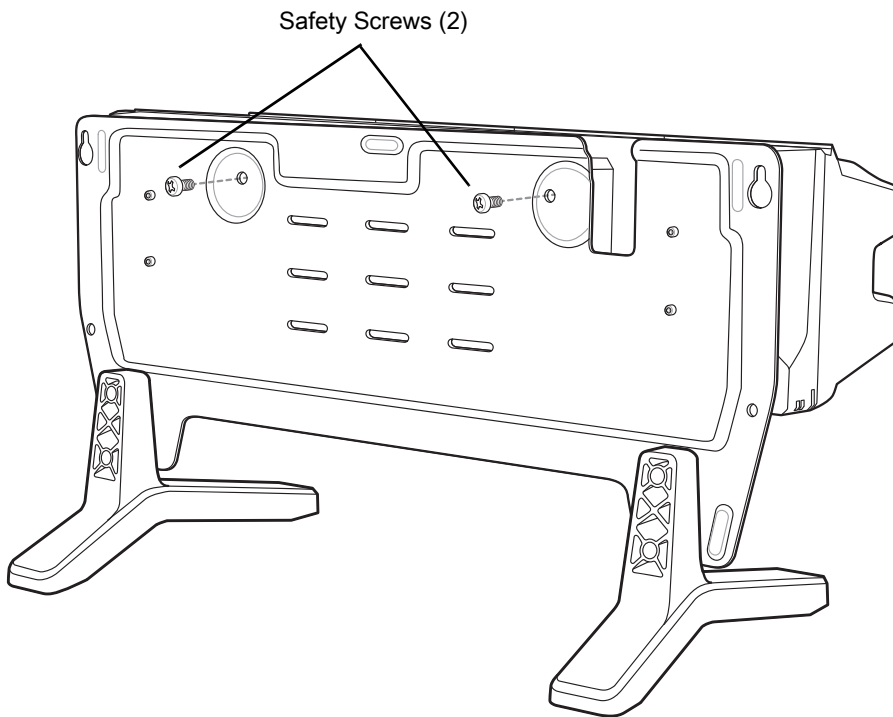
1. Align mounting slots on bottom of cradle with studs on plate.

**Figure 39** Install Cradle onto Desk Mount



2. Secure cradle to plate using two safety screws.

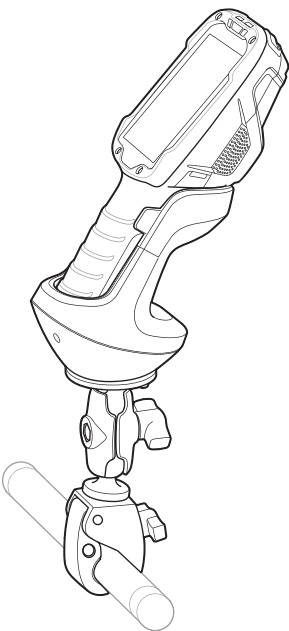
**Figure 40** Install Safety Screws



## Cart Mount

Use the Cart Mount to hold the device and perform hands-free scanning in Presentation Mode.

**Figure 41** Cart Mount

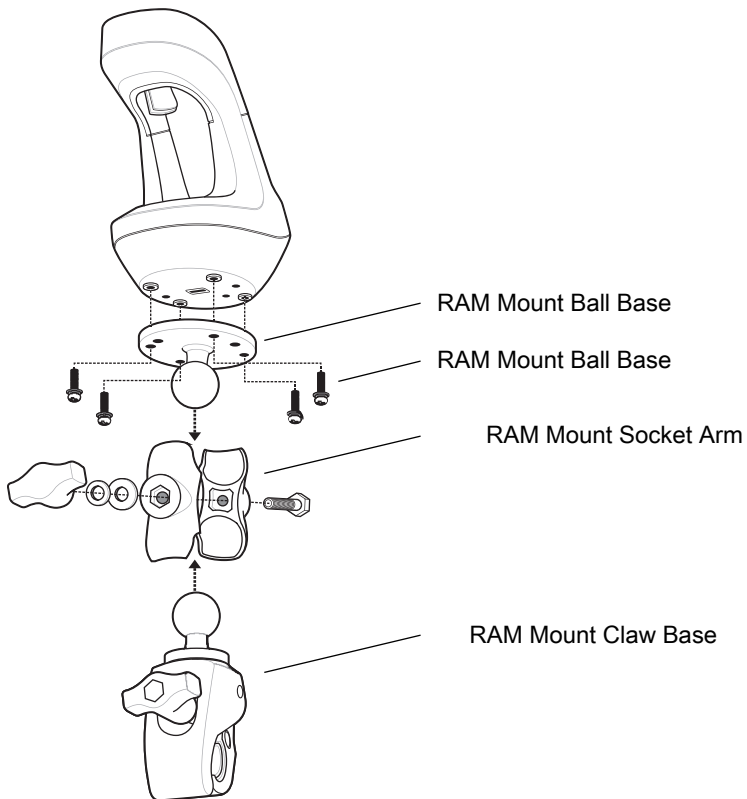


## Installation

To assemble the Cart Mount and RAM Mount:

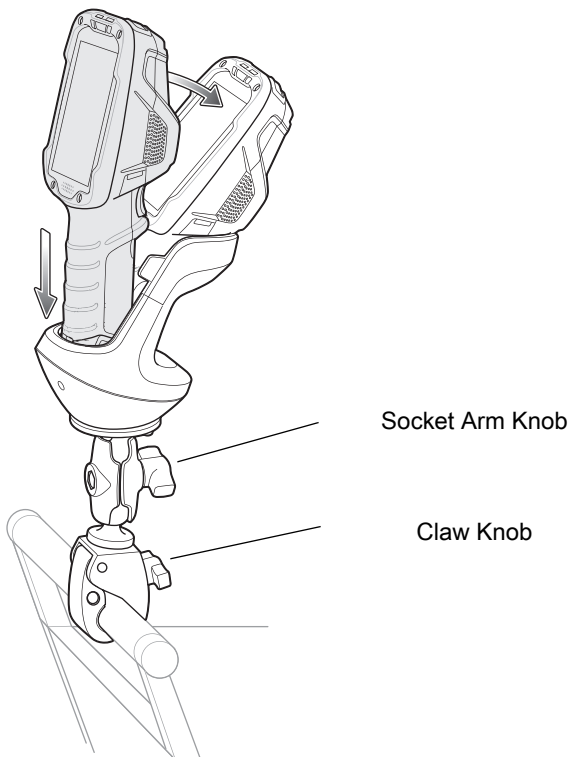
1. Secure the RAM Mount ball base to the bottom of the Cart Mount using four screws and four washers (provided).
2. Insert the socket arm to the ball base and claw base.
3. Slightly tighten the knob on the socket arm.

**Figure 42** Cart Mount Assembly



4. Squeeze the claw base and install on a cart rail.

**Figure 43** Cart Mount Installation on Cart Rail



5. Position the Cart Mount and tighten the claw knob and socket arm knob.
6. Insert the device handle into the Cart Mount cradle and rotate into the cradle.

## 5-Slot Cradle Rack Installation

Use the Rack/Wall Mount Bracket to mount a 5-slot cradle on a rack. When installing on a rack, first assemble the bracket and cradles/chargers and then install the assembly on the rack.

1. Place the power supply in bottom tray.
2. Connect AC line cord to power supply.
3. Connect DC line cord to power supply.
4. Secure power supply and cables to bottom tray with tie wraps.

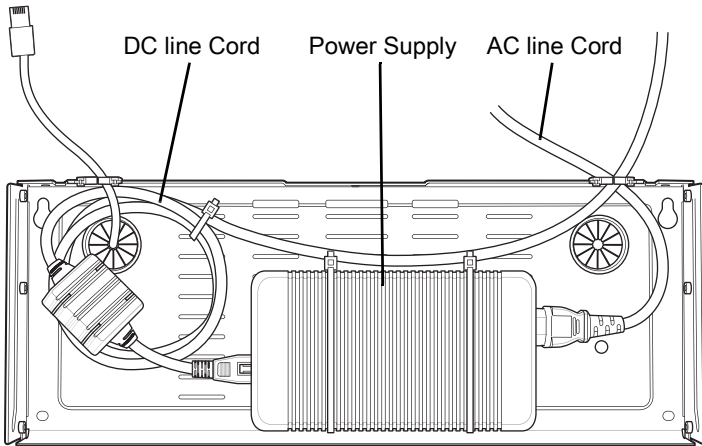


**NOTE:** Ensure tie wrap buckle is on side of power supply. Tie wrap buckle on top of power supply interferes with top tray.

5. Route cables through cable slots.

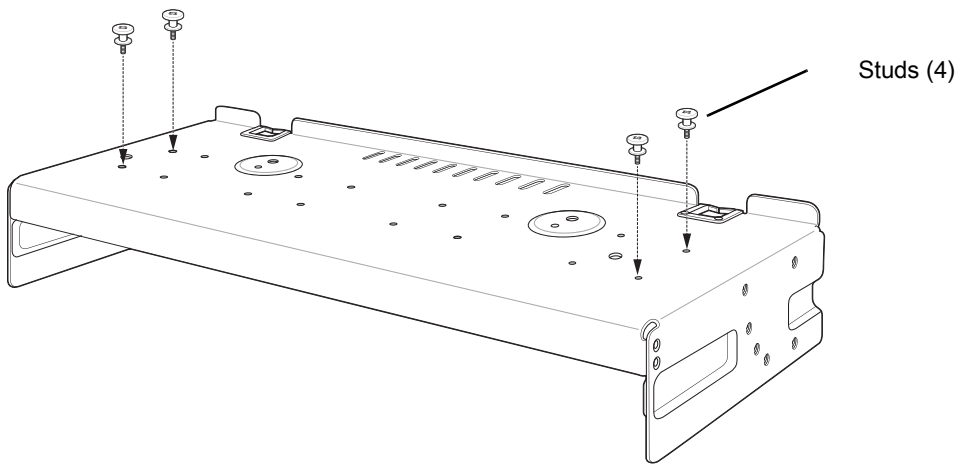


**Figure 44** Power Supply in Bottom Tray



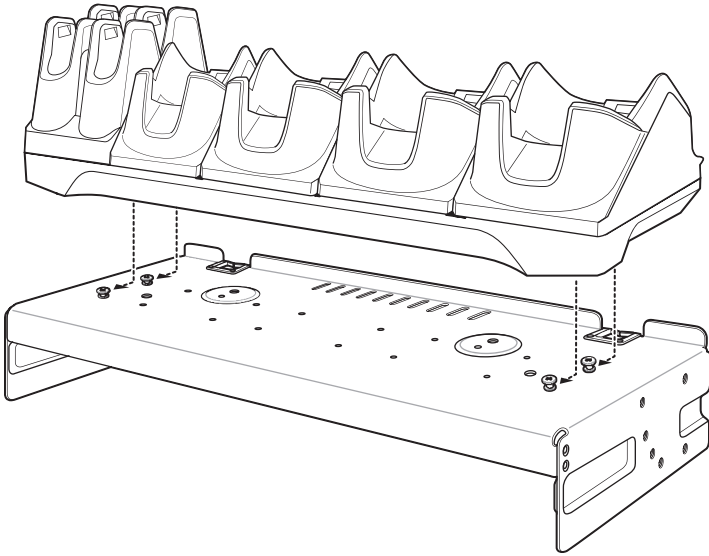
6. Secure four M2.5 studs to top tray as shown.

**Figure 45** Install Studs



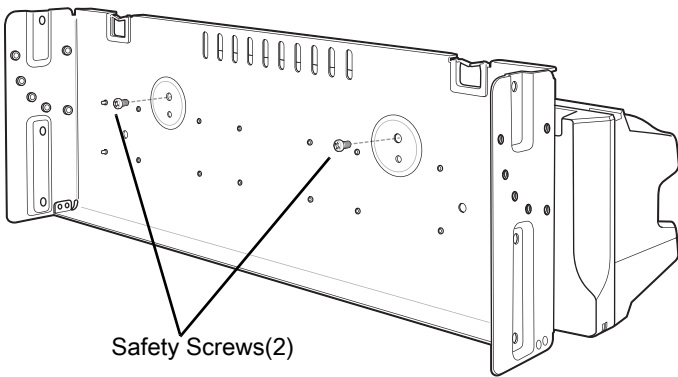
7. Align and install 5-Slot cradle onto studs of top tray.

**Figure 46** Align Cradle on Studs



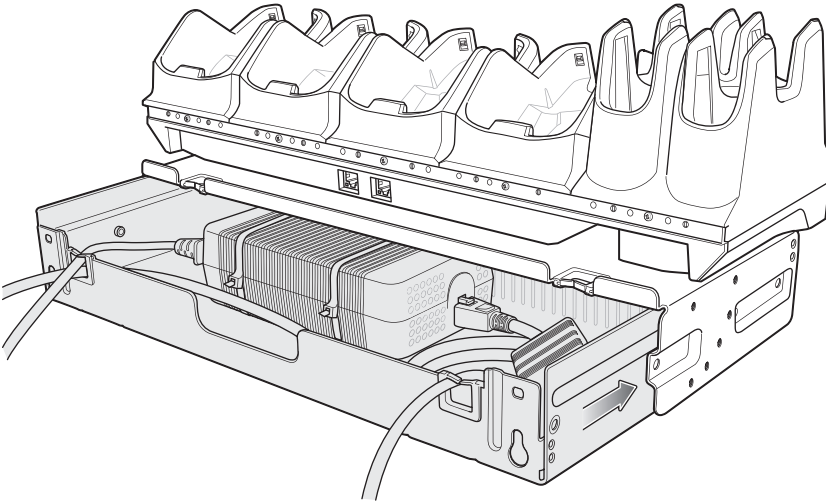
8. Secure cradle to top tray with two M2.5 safety screws.

**Figure 47** Secure Cradle



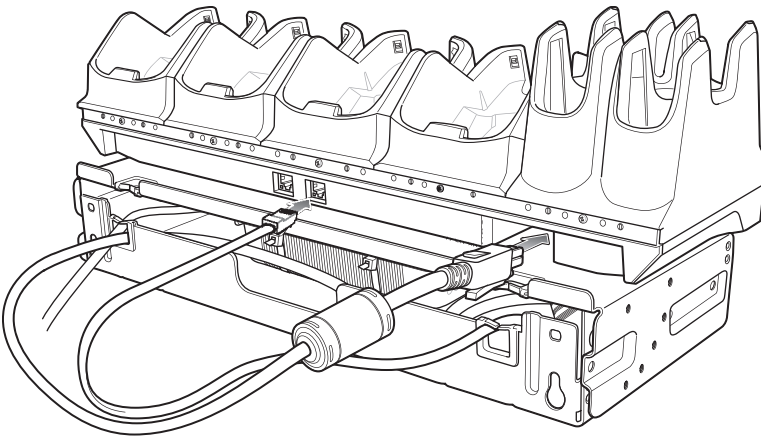
9. Slide top tray onto bottom tray.

**Figure 48** Slide Top Trap onto Bottom Tray

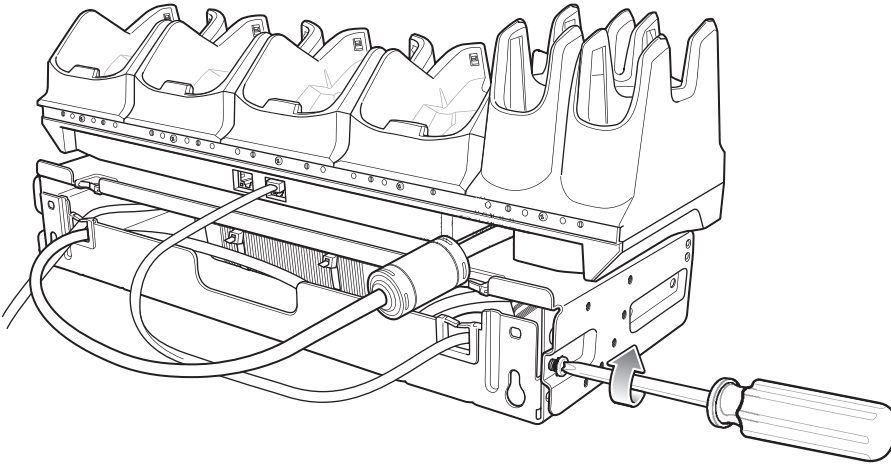


10. Connect cables to cradle.

**Figure 49** Connect Cables



11. Secure top tray to bottom tray with 4 M5 screws (two on each side).

**Figure 50** Secure Top and Bottom Tray

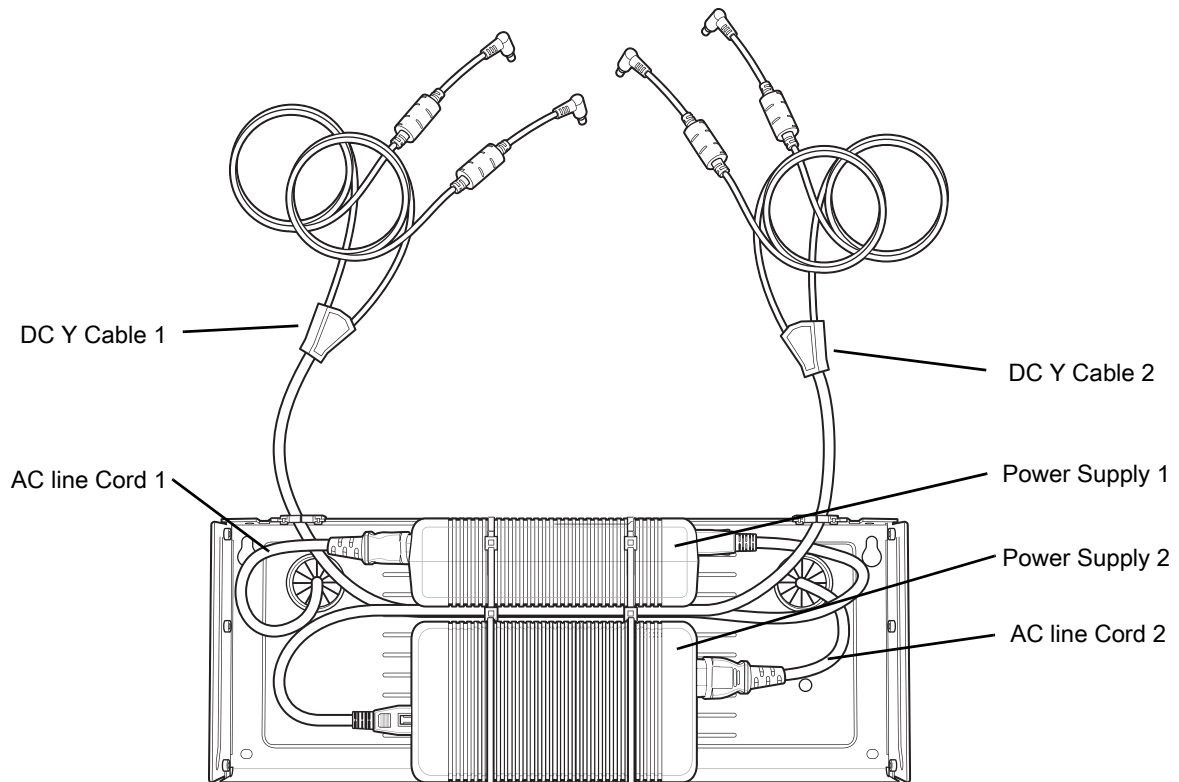
See [Rack Mount Installation on page 63](#) for installing the bracket assembly onto a rack.

## 4-Slot Battery Chargers Rack Installation

Use the Rack/Wall Mount Bracket to mount four 4-Slot Battery Chargers on a rack. When installing on a rack, first assemble the bracket and chargers and then install the assembly on the rack.

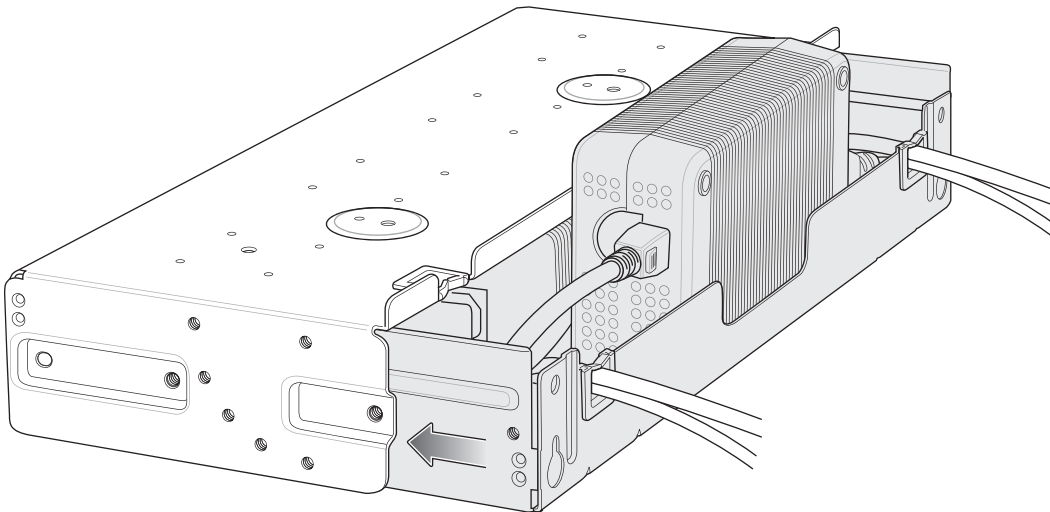
1. Place one power supply horizontally in bottom tray.
2. Place one power supply vertically in bottom tray.
3. Connect AC line cords to power supplies.
4. Connect DC line cords to power supplies.
5. Secure power supplies and cables to bottom tray with tie wraps.
6. Route cables through cable slots.

**Figure 51** Power Supplies in Bottom Tray



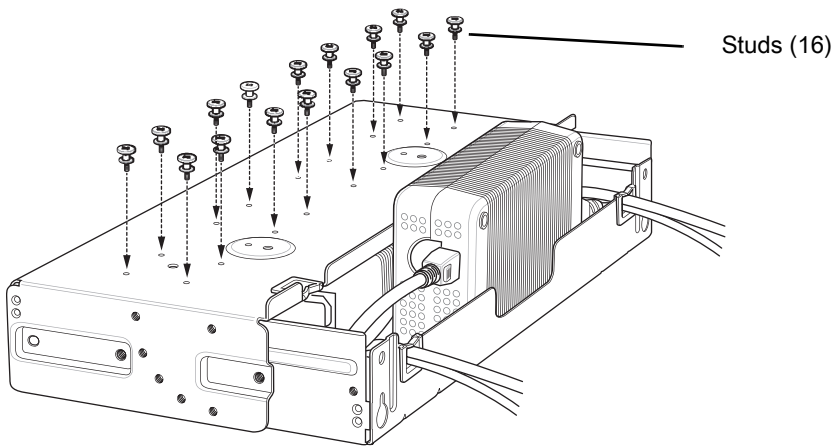
7. Slide top tray onto bottom tray until top tray touches vertical power supply.

**Figure 52** Slide top Tray onto Bottom Tray



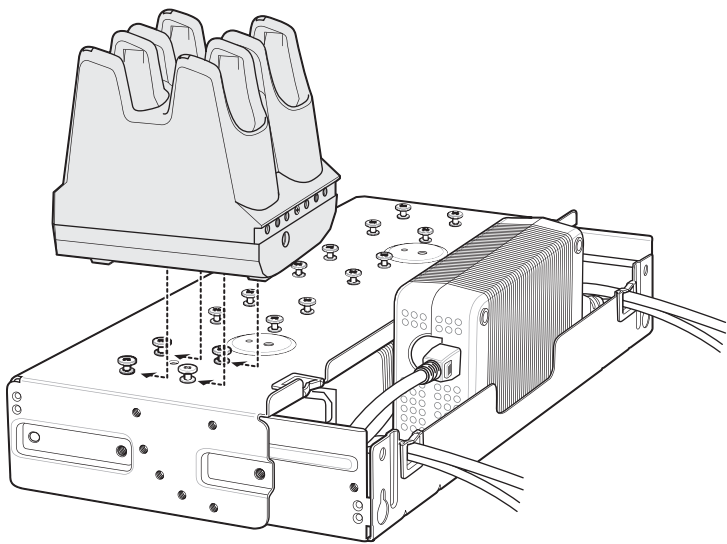
8. Install 16 M2.5 studs onto top tray as shown below.

**Figure 53** Install Studs



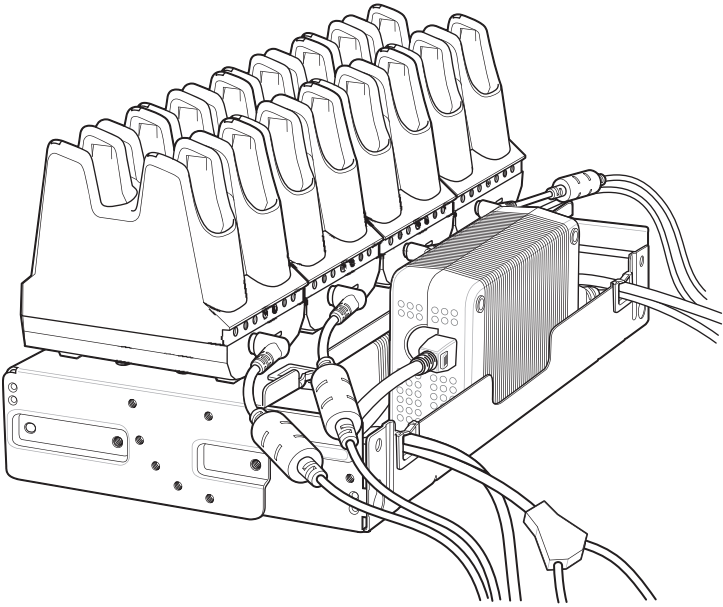
9. Align and install 4-Slot Battery Charger onto four studs.

**Figure 54** Align Chargers on Studs



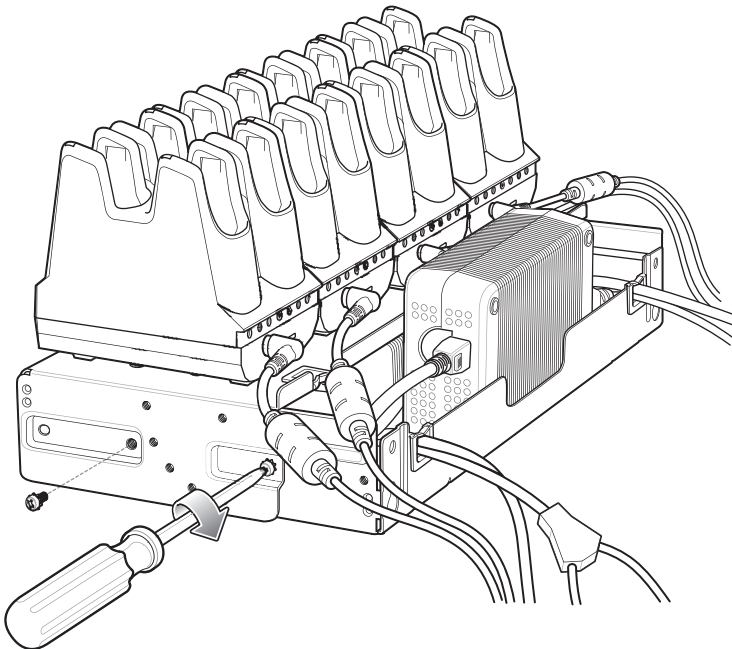
10. Connect DC Y cables to four 4-Slot Battery Chargers.

**Figure 55** Connect Cables



11. Secure top tray to bottom tray with four M5 screws (two on each side).

**Figure 56** Secure Top Tray to Bottom Tray



See [Rack Mount Installation on page 63](#) for installing the bracket onto a rack.

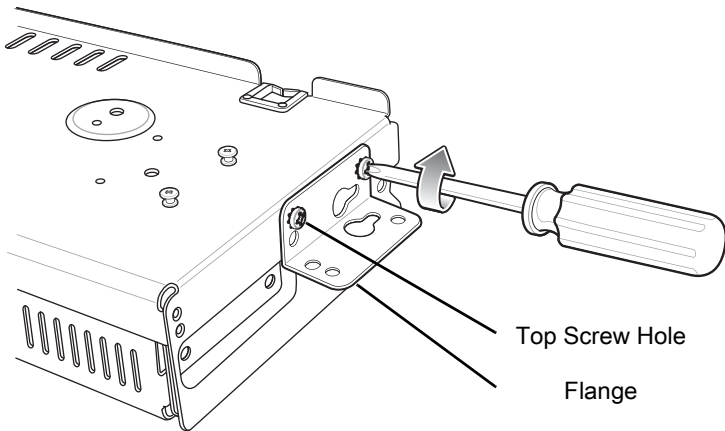
## Rack Mount Installation



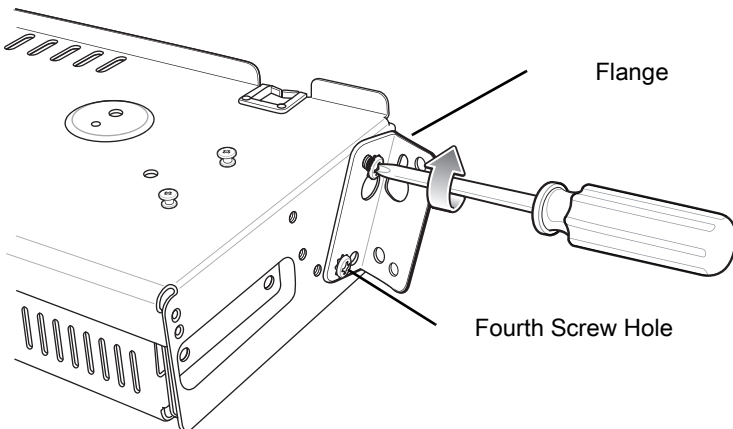
**NOTE:** Use screws provided with rack system. Refer to rack user documentation for instructions.

1. Secure mounting brackets to both sides of top tray with four M5 screws (two on each side). For 5-Slot cradles, position the flange for vertical installation. For 4-Slot Battery Chargers, position the flange for 25° installation.

**Figure 57** Flange Vertical Position (5-Slot Cradles)



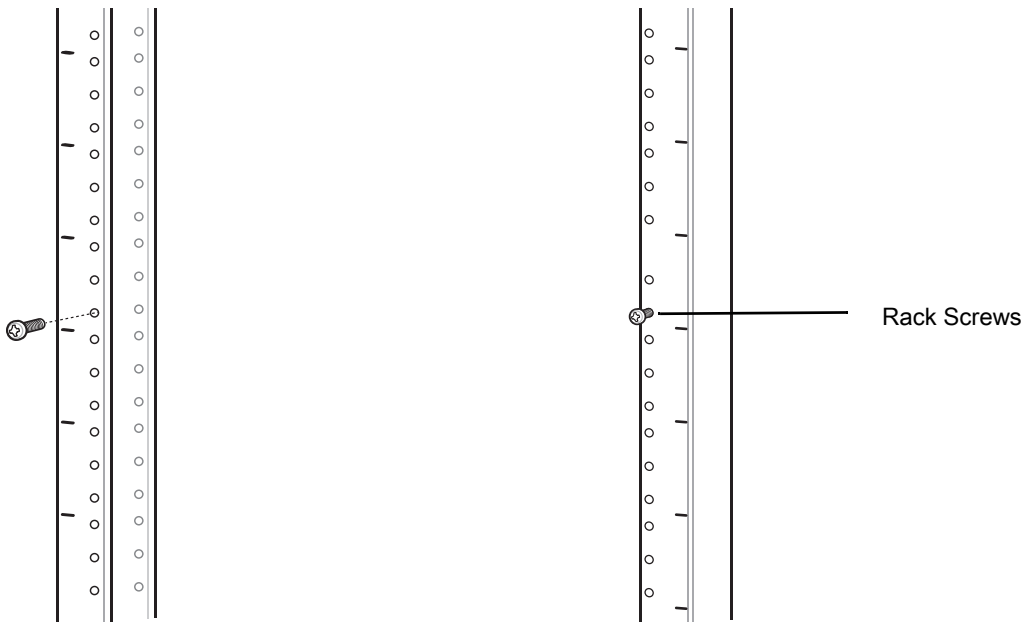
**Figure 58** Flange 25° Position (4-Slot Battery Chargers)



2. Install two rack system screws for top of mounting brackets. The screw heads should protrude half way from the rail.

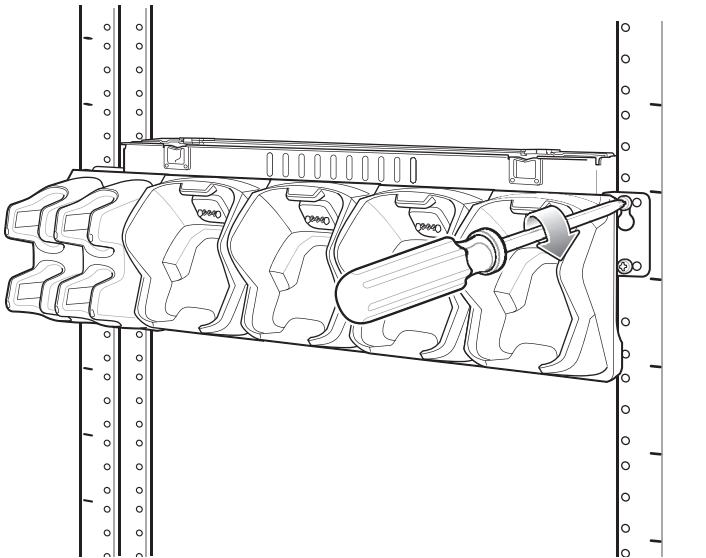


**Figure 59** Install Rack System Screws



3. Align the mounting bracket's top mounting key holes with the screws.
4. Place the brackets on the screws.

**Figure 60** Secure Bracket to Rack (Vertical Position Shown)



5. Secure the top screws.
6. Install bottom screws and tighten screws.
7. Route cables and connect to power source.



**CAUTION:** Installer should ensure that all building codes are followed when connecting the power supplies to an AC power

source.

While installing the brackets, power supplies and cables:

- Use tie wraps to secure cables to the bracket and rails.
- Coil cables wherever possible.
- Route power cables along the rails.
- Route inter-cradle cables to the side rails and then from the rails to the bracket.

## 5-Slot Cradle Wall Installation

Use the Rack/Wall Mount Bracket to mount a cradle on a wall. When installing on a wall, first assemble the bottom tray, install the bottom tray on the wall and then assemble the top tray.

Use mounting hardware (screws and/or anchors) appropriate for the type of wall mounting the bracket onto. The Mount Bracket mounting slots dimensions are 5 mm (0.2 in.). Fasteners must be able to hold a minimum of 20 Kg (44 lbs.)

For proper installation consult a professional installer. Failure to install the bracket properly can possibly result in damage to the hardware.

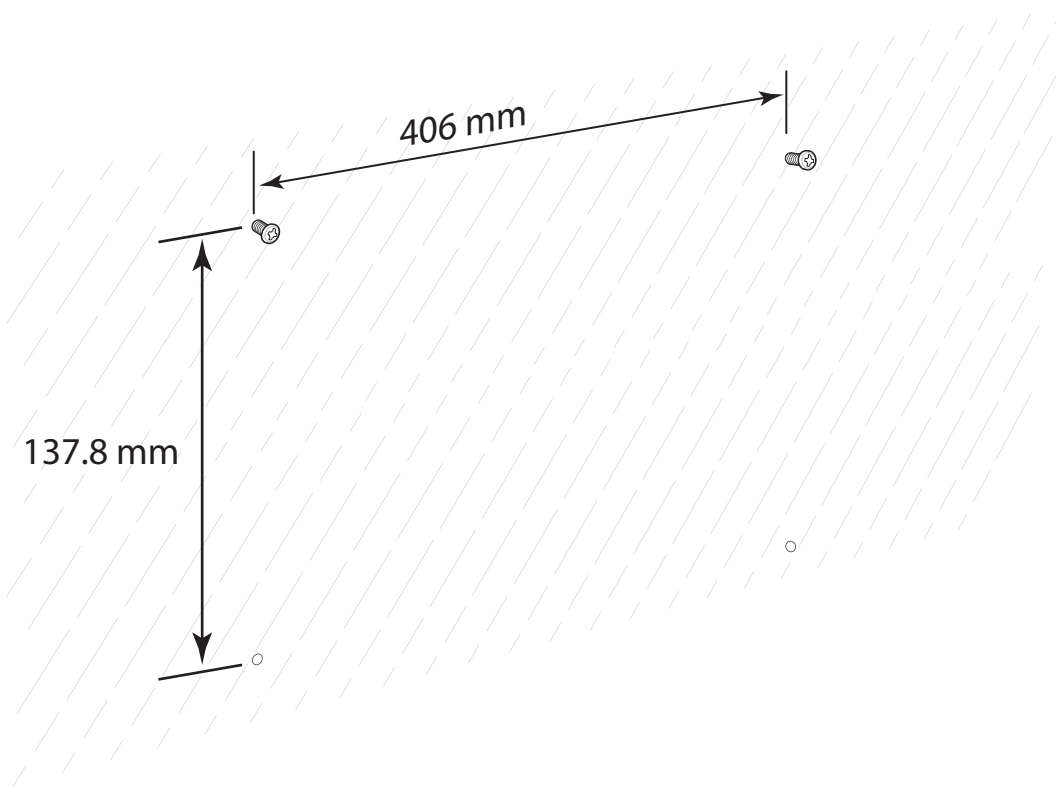
### Bottom Tray Assembly

See steps 1 through 5 in [5-Slot Cradle Rack Installation on page 56](#).

### Bracket Wall Mounting

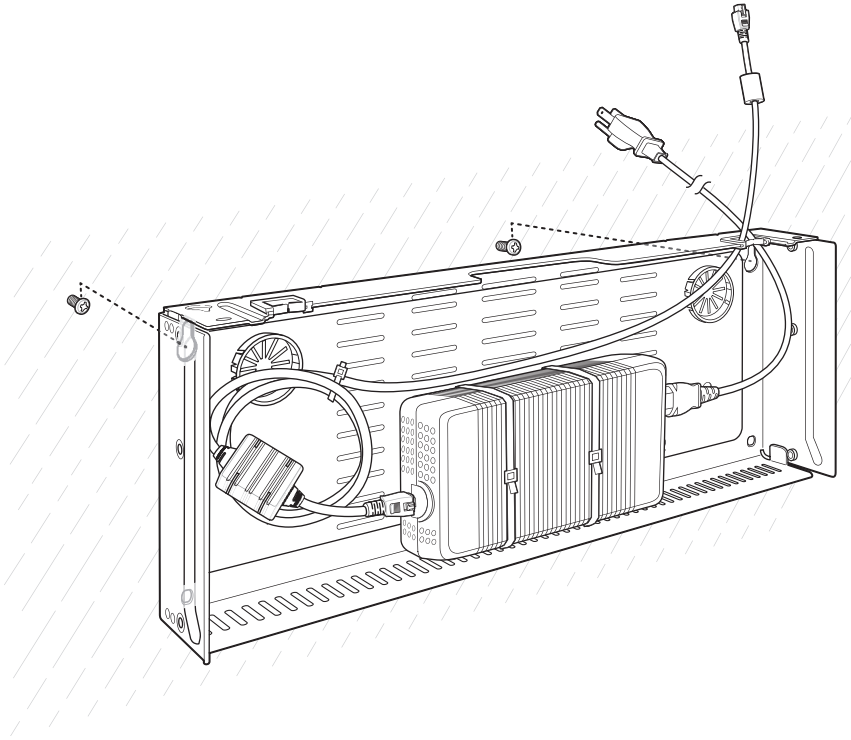
1. Drill holes and install anchors according to the template supplied with the bracket.
2. Install two screws for bottom of bracket. The screw heads should protrude 2.5 mm (0.01") from the wall.

**Figure 61** Vertical Wall Mounting Dimensions



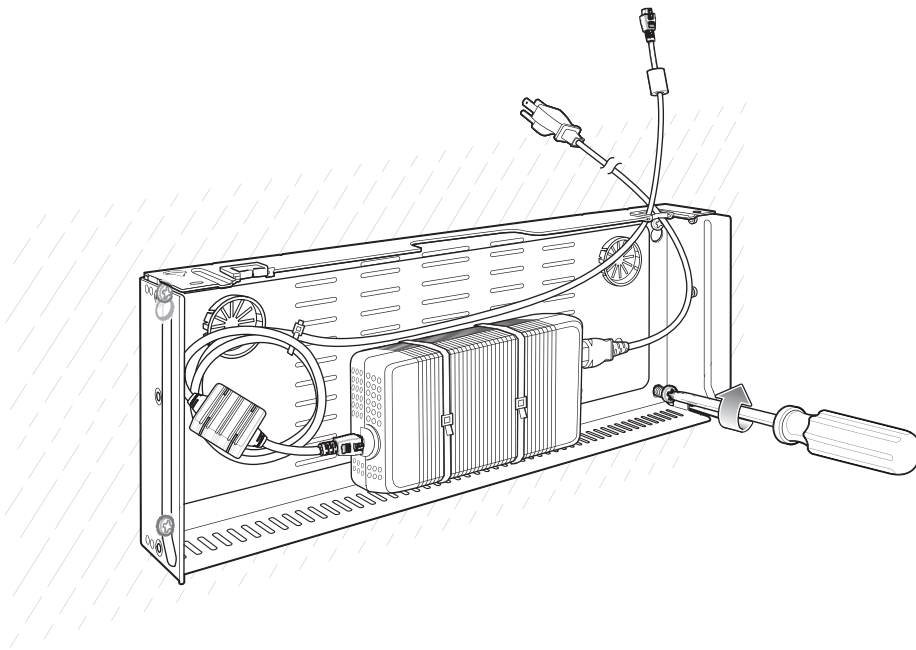
3. Align the mounting bracket's bottom mounting key holes with the screws.
4. Hang the bracket on the screws.

**Figure 62** Vertical Installation



5. Install two top screws.
6. Tighten all screws.

**Figure 63** Horizontal Installation - Tighten Screws



7. Assemble the top tray. See steps 6 through 8 in [5-Slot Cradle Rack Installation on page 56](#).
8. Slide the assembled top tray onto bottom tray.

9. Connect cables to cradle.
10. Secure top tray to bottom tray with four M5 screws (two on each side).
11. Route cables and connect to power source.



**CAUTION:** Installer should ensure that all building codes are followed when connecting the power supplies to an AC power source.

While installing the brackets, power supplies and cables:

- Use tie wraps to secure cables to the bracket.
- Coil cables wherever possible.
- Route power cables along wall and secure.

## 4-Slot Battery Charger Wall Installation

Use the Rack/Wall Mount Bracket to mount four 4-Slot Battery Chargers a cradle on a wall. When installing on a wall, first assemble the bottom tray, install the bottom tray on the wall and then assemble the top tray.

Use mounting hardware (screws and/or anchors) appropriate for the type of wall mounting the bracket onto. The Mount Bracket mounting slots dimensions are 5 mm (0.2 in.). Fasteners must be able to hold a minimum of 20 Kg (44 lbs.)

For proper installation consult a professional installer. Failure to install the bracket properly can possibly result in damage to the hardware.

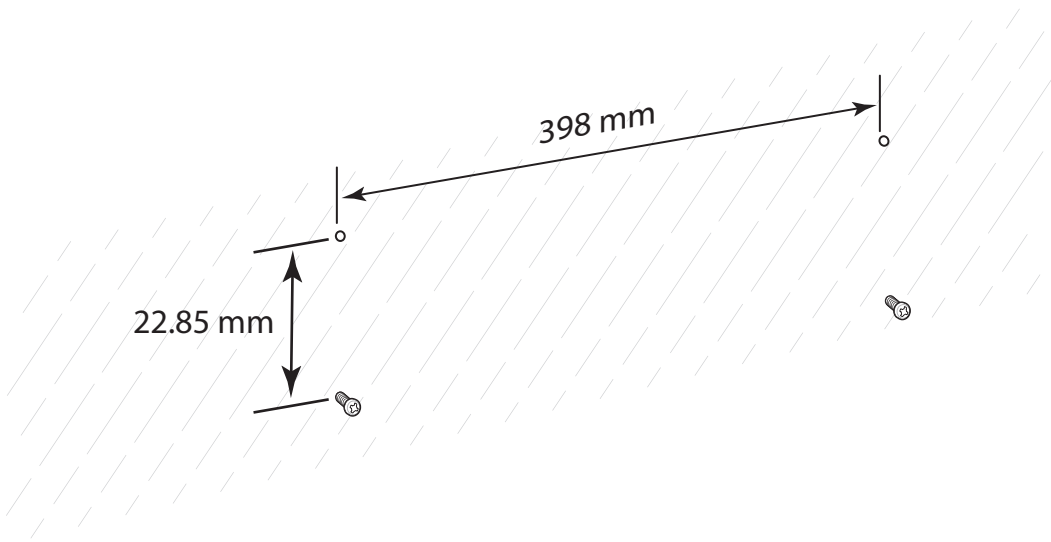
### Bottom Tray Assembly

See steps 1 through 5 in [4-Slot Battery Chargers Rack Installation on page 60](#).

### Bracket Wall Mounting

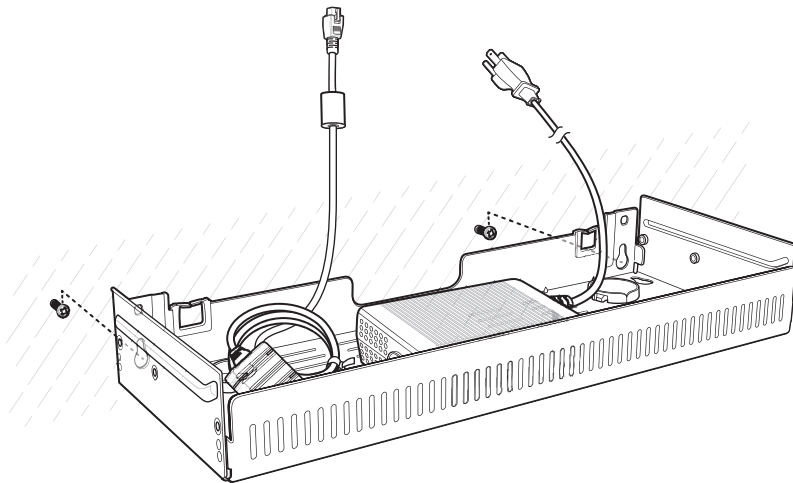
1. Drill holes and install anchors according to the template supplied with the bracket.
2. Install two screws for bottom of bracket. The screw heads should protrude 2.5 mm (0.01”) from the wall.

**Figure 64** Horizontal Mounting Template

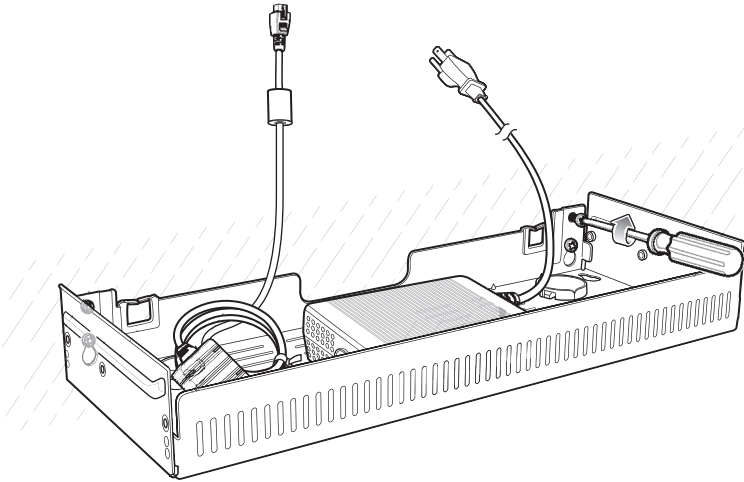


3. Align the mounting bracket's bottom mounting key holes with the screws.
4. Hang the bracket on the screws.

**Figure 65** Horizontal Installation



5. Install two top screws.
6. Tighten all screws.

**Figure 66** Horizontal Installation - Tighten Screws

7. Assemble the four 4-Slot Battery Chargers onto the bracket. See steps 7 through 11 in [4-Slot Battery Chargers Rack Installation on page 60](#).
8. Route cables and connect to power source.



**CAUTION:** Installer should ensure that all building codes are followed when connecting the power supplies to an AC power source.

While installing the brackets, power supplies and cables:

- Use tie wraps to secure cables to the bracket and rails.
- Coil cables wherever possible.
- Route power cables along the rails.
- Route inter-cradle cables to the side rails and then from the rails to the bracket.

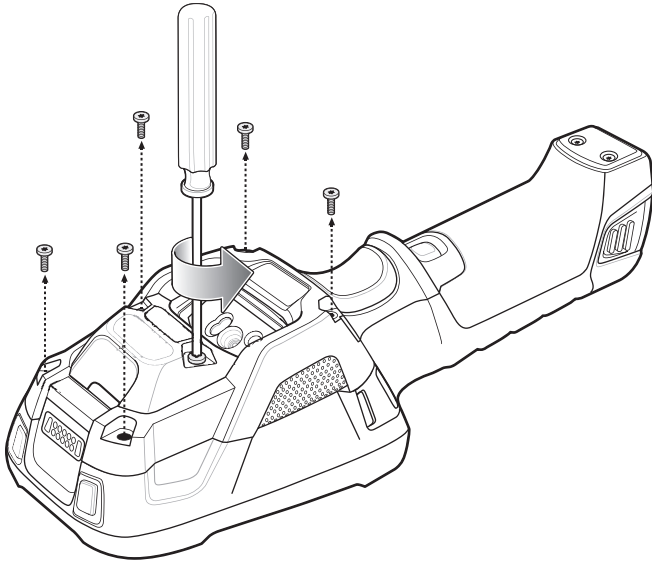
## Condensation Resistant Rear Bezel Replacement

The Condensation Resistant configurations contain a desiccant pack that must be replaced every five months. The desiccant pack is part of the Back Bezel. Replacement Back Bezel with desiccant pack comes in a vacuum sealed package. Do not open the package until instructed in the steps below. Install immediately after opening.

To replace the Back Bezel:

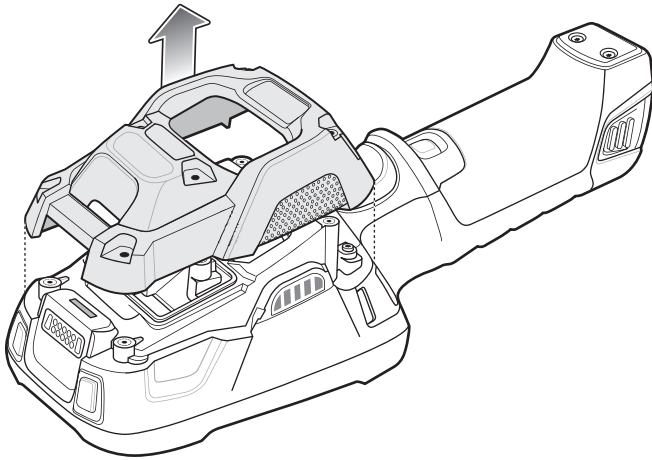
1. Remove six screws securing the Back Bezel.

**Figure 67** Remove Screws



2. Lift Rear Bezel.

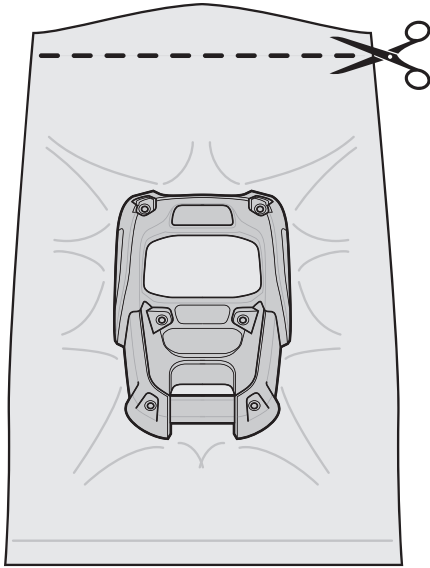
**Figure 68** Lift Rear Bezel



3. Cut the package open with scissors.

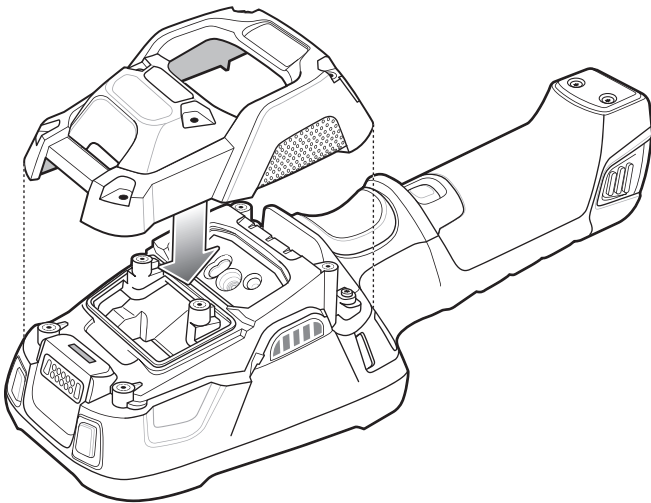


**Figure 69** Open Vacuum Bag



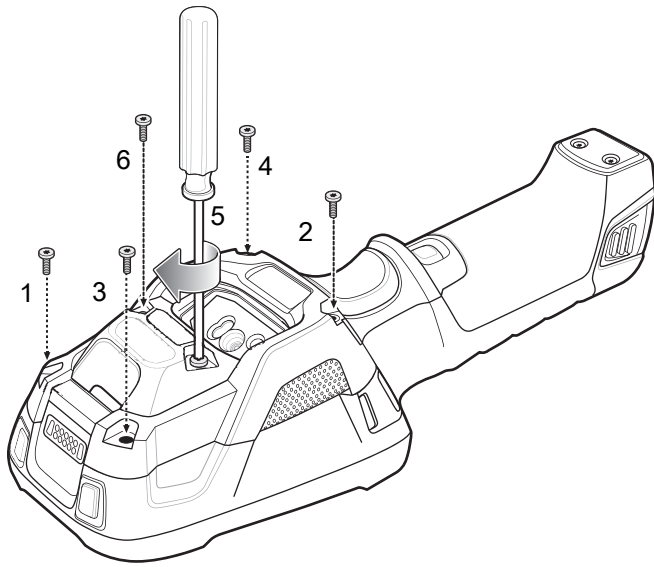
4. Remove Rear Bezel from package.
5. Align Rear Bezel with device.

**Figure 70** Align Back Bezel



6. Secure Rear Bezel using six screws with a torque requirement of  $4.5 \pm 0.2$  kgf.cm.

Figure 71 Secure Back Bezel



# USB Communication

## Introduction

This chapter provides information for transferring files between the device and a host computer.

## Transferring Files with a Host Computer via USB

Connect the device to a host computer using a USB cable to transfer files between the device and the host computer.

When connecting the device to a host computer, follow the host computer's instructions for connecting and disconnecting USB devices, to avoid damaging or corrupting files.

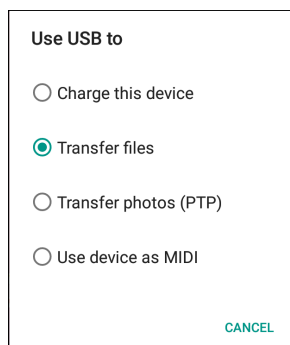
## Transferring Files



**NOTE:** Use Transfer files to copy files between the device (internal memory) and the host computer.

1. Connect a USB cable to the device.
2. Pull down the Notification panel and touch **USB charging this device**.  
By default, **Charge this device** is selected.

**Figure 1** Use USB to Dialog Box



3. Touch **Transfer files**.
4. On the host computer, open a file explorer application.
5. Locate the **device** as a portable device.

6. Open the **Internal storage** folder.
7. Copy files to and from the device or delete files as required.

## Connecting to the TC8300 as a Media Device



**NOTE:** Using Media Device, you can copy files to either the microUSB card or internal memory.

1. Connect the USB Charge cable to the device and then to the host computer.
2. **Connected as a media device** or **Connected as a camera** appears on the Status bar.
3. If **Connected as a camera** appears, pull down the Notification shade and touch **Connected as a camera** and then touch **Media device (MTP)**.
4. On the host computer, open a file explorer application.
5. Locate the **TC8300** as a portable device.
6. Open the **SD card**, **Internal storage** or **Enterprise storage** folder.
7. Copy or delete files as required.

## Connecting to the TC8300 as a Camera



**NOTE:** Using Camera, you can copy files to internal memory.

1. Connect the USB and Charging cable to the device and then to the host computer.
2. **Connected as a media device** or **Connected as a camera** or appears on the Status bar.
3. If **Connected as a media device** appears, pull down the Notification shade and touch **Connected as a media device** and then touch **Camera (PTP)**.
4. On the host computer, open a file explorer application.
5. Locate the **TC8300** as a portable device.
6. Open the **Internal storage** folder.
7. Copy or delete photos as required.

## Disconnect from the Host Computer

To disconnect the device from the host computer:



**CAUTION:** Carefully follow the host computer's instructions to disconnect USB devices correctly to avoid losing information.

1. On the host computer, unmount the device.
2. Remove the USB from the device.


# DataWedge

## Introduction

This chapter applies to DataWedge on Android devices. DataWedge is an application that reads data, processes the data and sends the data to an application.

## Accessing DataWedge

To access DataWedge:

1. Swipe up from the bottom of the Home screen and touch .

## Basic Scanning

Scanning can be performed using the following:

## Profiles

DataWedge is based on profiles and plug-ins. A profile contains information on how DataWedge should behave with different applications.

Profile information consists of:

- Associated application
- Input plug-in configurations
- Output plug-in configurations
- Process plug-in configurations.

Using profiles, each application can have a specific DataWedge configuration. For example, each user application can have a profile which outputs scanned data in the required format when that application comes to the foreground. DataWedge can be configured to process the same set of captured data differently based on the requirements of each application.

DataWedge includes the following pre-configured profiles which support specific built-in applications:

- Visible profiles:
  - **Profile0** - created automatically the first time DataWedge runs. Generic profile used when there are no user created profiles associated with an application.
  - **Launcher** - enables scanning when the Launcher is in foreground.
  - **DWDemo** - provides support for the DWDemo application.

Some Zebra applications are capable of capturing data by scanning. DataWedge is pre-loaded with private and hidden profiles for this purpose. There is no option to modify the private profiles.

## Profile0

**Profile0** can be edited but cannot be associated with an application. That is, **DataWedge** allows manipulation of plug-in settings for **Profile0** but it does not allow assignment of a foreground application. This configuration allows **DataWedge** to send output data to any foreground application other than applications associated with user-defined profiles when **Profile0** is enabled.

**Profile0** can be disabled to allow **DataWedge** to only send output data to those applications which are associated in user-defined profiles. For example, create a profile associating a specific application, disable **Profile0** and then scan. **DataWedge** only sends data to the application specified in the user-created profile. This adds additional security to **DataWedge** enabling the sending of data only to specified applications.

## Plug-ins

A plug-in is a software module utilized in DataWedge to extend its functionality to encompass technologies such as barcode scanning. The plug-ins can be categorized into three types based on their operations:

- Input Plug-ins
- Output Plug-ins
- Process Plug-ins.

### Input Plug-ins

An Input Plug-in supports an input device, such as a barcode scanner contained in, or attached to the device. **DataWedge** contains base plug-ins for these input devices.

**Barcode Scanner Input Plug-in** – The Barcode Scanner Input Plug-in is responsible for reading data from the integrated barcode scanner and supports different types of barcode readers including laser, imager and internal camera. Raw data read from the barcode scanner can be processed or formatted using Process Plug-ins as required. **DataWedge** has built-in feedback functionality for the barcode scanner to issue user alerts. The feedback settings can be configured according to user requirement.

### Process Plug-ins

Process Plug-ins are used in **DataWedge** to manipulate the received data according to the requirement, before sending to the foreground application via the Output Plug-in.


- **Basic Data Formatting Process Plug-in** – The Basic Data Formatting Plug-in allows **DataWedge** to add a prefix and/or a suffix to the captured data before passing it to an Output Plug-in.
- **Advanced Data Formatting Process Plug-in** – The Advanced Data Formatting Plug-in allows **DataWedge** to apply rules (actions to be performed based on defined criteria) to the data received via an input plug-in before passing it to an Output Plug-in.

## Output Plug-ins

Output Plug-ins are responsible for sending the data from Input Plug-ins to a foreground application on the device.

- **Keystroke Output Plug-in** – The Keystroke Output Plug-in collects and sends data received from the Input Plug-in to the foreground applications by emulating keystrokes.
- **Intent Output Plug-in** – The Intent Output Plug-in collects and sends data received from the Input Plug-ins to foreground applications using the Android Intent mechanism.
- **IP Output Plug-in** – The IP Output Plug-in collects and sends data received from the Input Plug-ins to a host computer via a network connection. Captured data can be sent over an IP network to a specified IP address and port using either TCP or UDP transport protocols.

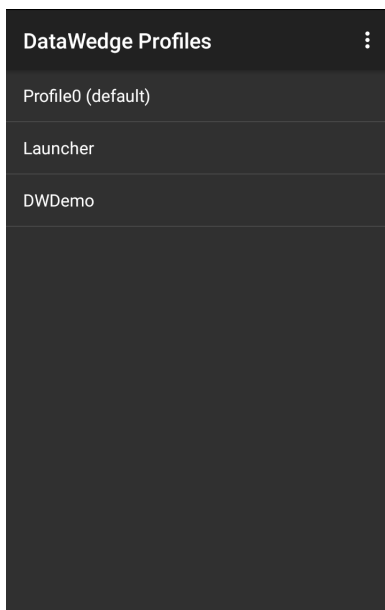
## Profiles Screen

To launch DataWedge, swipe up from the bottom of the screen and touch . By default, three profiles appear:

- **Profile0**
- **Launcher**
- **DWDemo**

Profile0 is the default profile and is used when no other profile can be applied.

**Figure 1** DataWedge Profiles Screen



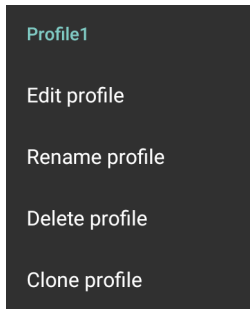
Profile names are color coded. Enabled profiles are white and disabled profiles are gray.

To configure a profile touch the profile name.

## Profile Context Menu

Touch and hold a profile to open a context menu that allows additional actions to be performed on the selected profile.

Figure 2 Profile Context Menu



The profile context menu allows the profile to be edited (same as just tapping on a profile), renamed or deleted.

## Options Menu


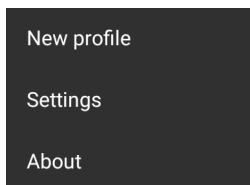


Touch  to open the options menu.

Figure 3 DataWedge Options Menu



The menu provides options to create a new profile, access to general DataWedge settings and DataWedge version information.

## Disabling DataWedge

1. Swipe up from the bottom of the screen and touch .
2. Touch .
3. Touch **Settings**.
4. Touch **DataWedge enabled**.

The blue check disappears from the checkbox indicating that DataWedge is disabled.

## Creating a New Profile

To create a new profile:



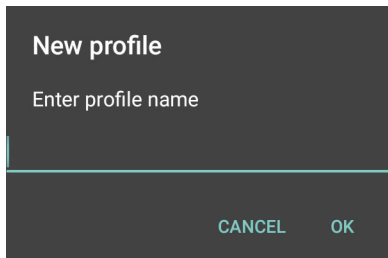
1. Swipe up from the bottom of the screen and touch .
2. Touch .
3. Touch **New profile**.
4. In the **New profile** dialog box, enter a name for the new profile. It is recommended that profile names be unique and made up of only alpha-numeric characters (A-Z, a-z, 0-9).



Figure 4 New Profile Name Dialog Box



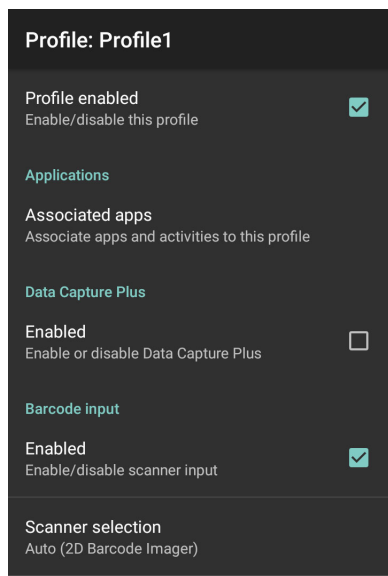
5. Touch **OK**.

The new profile name appears in the **DataWedge profile** screen.

## Profile Configuration

To configure the Profile0 or a user-created profile, touch the profile name.

Figure 5 Profile Configuration Screen



The configuration screen lists the following sections:

- Profile enabled
- Applications
- Data Capture Plus (DCP)
- Barcode Input
- Keystroke output
- Intent Output
- IP Output.

## Associating Applications

Use Applications option to associate applications with this profile. User created profiles should be associated with one or more applications and its activities.

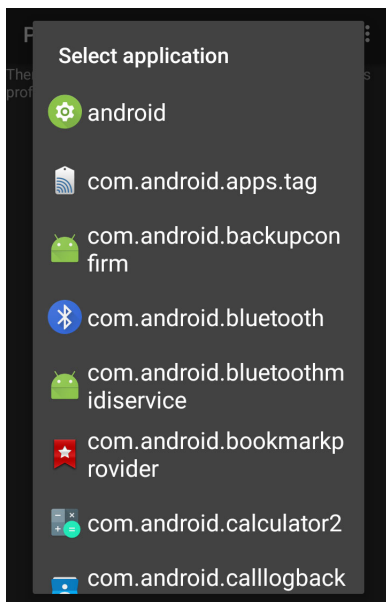
1. Touch **Associated apps**. A list of applications/activities associated with the profile displays. Initially the list does not contain any applications/activities.


**Figure 6** Associated Apps Screen



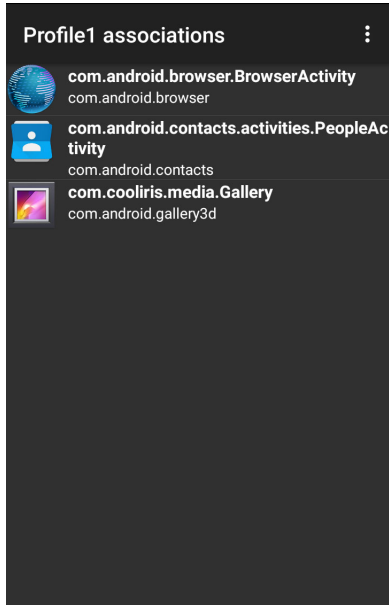
2. Touch **⋮**.
3. Touch **New app/activity**.

**Figure 7** Select Application Menu



4. In the **Select application** screen, select the desired application from the list.
5. In the **Select activity** menu, selecting the activity adds that application/activity combination to the associated application list for that profile. Selecting \* as the activity results in all activities within that application being associated to the profile. During operation, DataWedge tries to match the specific application/activity combinations with the foreground application/activity before trying to match the general application/\* combinations.
6. Touch .

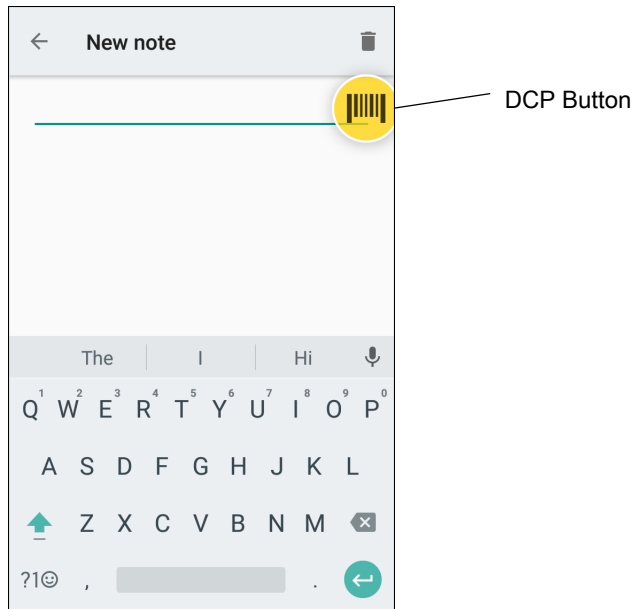
**Figure 8** Selected Application/Activity



## Data Capture Plus

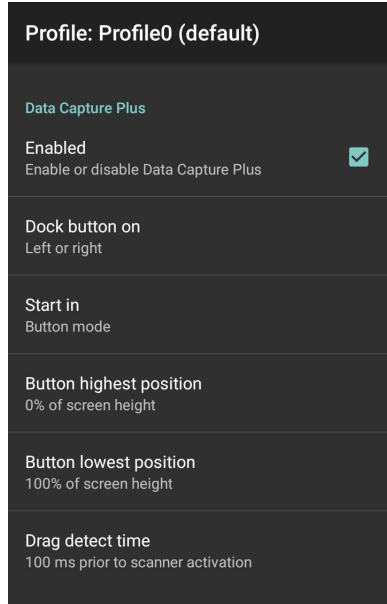
Data Capture Plus (DCP) is a DataWedge feature that enables the user to initiate data capture by touching a designated part of the screen. A variable screen overlay acts like a scan button.

Figure 9 Minimized Data Capture Panel



The DataWedge profile configuration screen allows the user to configure how the DCP appears on the screen once the particular profile is enabled. The DCP is hidden by default. Enabling DCP option displays seven additional configuration parameters.

Figure 10 Data Capture Panel Settings



- **Enable** - Select to enable Data Capture Plus (default - disabled).
- **Dock button on** - Select position of the button.
  - **Left or right** - Allows user to place the button on either the right or left edge of the screen.
  - **Left only** - Places the button on left edge of the screen.
  - **Right only** - Places the button on the right edge of the screen.

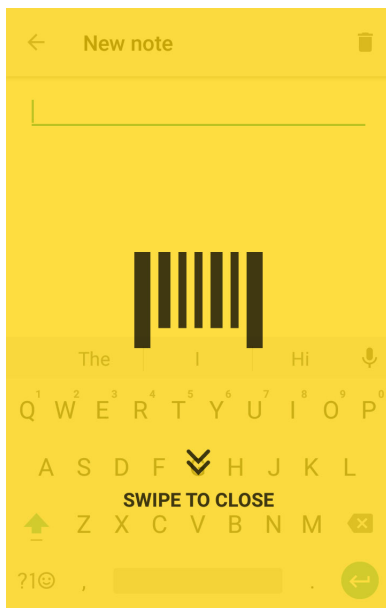
- **Start in** - Select the initial DCP state.
  - **Fullscreen mode** - DCP covers the whole screen.
  - **Button mode** - DCP displays as a circular button on the screen and can be switched to fullscreen mode.
  - **Button only mode** - DCP displays as a circular button on the screen and cannot be switched to fullscreen mode.
- **Button highest position** - Select the top of the range the user is allowed to move the DCP, given as a percent of the screen height (default - 0).
- **Button lowest position** - Select the bottom of the range the user is allowed to move the DCP, given as a percent of the screen height (default - 100).
- **Drag detect time** - Select the time in milliseconds that the scanner waits before activating scanner. This allows the user to drag the button without initiating scanner (default - 100 ms, maximum 1000 ms).



**NOTE:** The DCP does not appear if the scanner is disabled in the profile even though the **Enabled** option is set.

In Button mode, the user can place DCP in full screen mode by dragging the button over **Fullscreen mode**. The overlay covers the screen.

Figure 11 Maximized DCP



Swipe down to return to button mode.

## Barcode Input

Use the **Barcode Input** options to configure the Barcode Scanner Input Plug-in for the profile.

### Enabled

Enables or disables this plug-in. A check in the checkbox indicates that the plug-in is enabled.

### Scanner Selection

Configures which scanning device to use for barcode data capture when the profile is active.

- **Auto ( 2D Barcode Imager)**
- **2D Barcode Imager**
- **Auto (Serial SSI Scanner)**
- **Serial SSI Scanner**
- **Camera Scanner**
- **Bluetooth Scanner**
- **RS6000 Bluetooth Scanner**
- **DS3678 Bluetooth Scanner**
- **LI3678 Bluetooth Scanner**
- **DS2278 Bluetooth Scanner**
- **DS8178 Bluetooth Scanner**

## Hardware Trigger

Enables or disables the hardware trigger for scanning (Default - enabled). If disabled, pressing the hardware trigger will not scan a barcode. When the hardware trigger is disabled, it cannot be used for starting the scanning beam, but if scanning is started by a soft scan trigger intent, then a hardware trigger press cancels the scan.

## Auto Switch to Default on Event

This feature configures DataWedge to select an external scanner as the default scanning device immediately upon connection and revert to a built-in scanner when the external scanner is disconnected. External scanners include those connecting by Bluetooth, serial cable or snap-on module. Disabled by default. This is only available when **Scanner Selection** is set to **Auto**.

This helps reduce scanning workflow interruptions when a Bluetooth scanner is introduced and/or it becomes disconnected due to losing power or moving out of range.

For Bluetooth scanners, if the device was not previously paired, a pairing barcode displays prior to automatic connection.

- **Disabled** - No scanner switching occurs when an external scanner is connected or disconnected (default).
- **On connect** - Selects the external scanner as the default scanning device immediately upon connection.
- **On disconnect** - Reverts to a built-in scanner based on its position in an internally managed scanner list (which varies by host device). This is usually the scanner most recently used prior to the external connection (see notes below).
- **On connect/disconnect** - Selects an external scanner as the default scanning device immediately upon connection. Upon disconnection, reverts to the scanner set as the default prior to the external connection.



**NOTE:** The system selects the default scanner based on the connection state and the scanner's position in an internally managed scanner list. If the newly connected scanner is lower in the scanner list than the one currently selected as the default scanner, the newly connected scanner becomes the default scanner.

On devices with only one built-in scanner or imager, **On disconnect** reverts to that built-in scanner or imager.

## Configure Scanner Settings

Select Configure Scanner Settings to set the following:

- Select scanner to set parameters
- Decoders

- Decoder params
- UPC/EAN params
- Reader params
- Scan params
- UDI params
- Multibarcodes params
- Keep enabled on suspend

## Select Scanner to Set Parameters

Select a scanner from the available options to set the parameters for or select **All Scanners**.

## Decoders

Configures which barcode decoders are enabled or disabled. For best performance disable all unnecessary decoders.

Touch **Decoders**. The **Barcode input** screen appears. A check in the checkbox indicates that the decoder is enabled. By default the most commonly used decoders are enabled (shown below with an asterisk). The supported decoders are:



**NOTE:** DataWedge supports the decoders listed below but not all are validated on this device.


Table 1 Supported Decoders

Decoders	Camera	Internal Imager 965	Internal Imager SE4850-ER, SE4770-SR, SE4750-MR	Internal Imager SE4750-DP/SE4750-DPA	RS6000	DS2278	DS3678	LI3678	DS8178
Australian Postal	O	--	O	O	O	O	O	--	O
Aztec	X	--	X	X	X	X	X	--	X
Canadian Postal	O	--	O	O	O	--	--	--	--
Chinese 2 of 5	O	O	O	O	O	O	O	O	O
Codabar	X	X	X	X	X	X	X	X	X
Code 11	O	O	O	O	O	O	O	O	O
Code 128	X	X	X	X	X	X	X	X	X
Code 39	X	X	X	X	X	X	X	X	X
Code 93	O	O	O	O	O	O	O	O	O
Composite AB	O	--	O	O	O	O	O	--	O
Composite C	O	--	O	O	O	O	O	--	O
Discrete 2 of 5	O	O	O	O	O	O	O	O	O
Datamatrix	X	--	X	X	X	X	X	--	X
Dutch Postal	O	--	O	O	O	O	O	--	O
DotCode	X	O	X	O	O	O	O	O	O
EAN13	X	X	X	X	X	X	X	X	X
EAN8	X	X	X	X	X	X	X	X	X
Grid Matrix	O	O	O	O	O	O	O	O	O
GS1 DataBar	X	X	X	X	X	X	X	X	X
GS1 DataBar Expanded	X	X	X	X	X	X	X	X	X
GS1 DataBar Limited	O	O	O	O	O	O	O	O	O
GS1 Datamatrix	O	--	O	O	O	O	O	--	O
GS1 QRCode	O	--	O	O	O	O	O	--	O



Table 1 Supported Decoders (Continued)

Decoders	Camera	Internal Imager 965	Internal Imager SE4850-ER, SE4770-SR, SE4750-MR	Internal Imager SE4750-DP/SE4750-DPA	RS6000	DS2278	DS3678	LI3678	DS8178
HAN XIN	O	--	O	O	O	O	O	--	O
Interleaved 2 of 5	O	O	O	O	O	O	O	O	O
Japanese Postal	O	--	O	O	O	O	O	--	O
Korean 3 of 5	O	O	O	O	O	O	O	O	O
MAIL MARK	X	--	X	X	X	X	X	--	X
Matrix 2 of 5	O	O	O	O	O	O	O	O	O
Maxicode	X	--	X	X	X	X	X	--	X
MicroPDF	O	--	O	O	O	O	O	--	O
MicroQR	O	--	O	O	O	O	O	--	O
MSI	O	O	O	O	O	O	O	O	O
PDF417	X	--	X	X	X	X	X	--	X
QR Code	X	--	X	X	X	X	X	--	X
Decoder Signature	O	--	O	O	O	O	--	--	--
TLC 39	O	O	O	O	O	O	O	O	O
Trioptic 39	O	O	O	O	O	O	O	O	O
UK Postal	O	--	O	O	O	O	O	--	O
UPCA	X	X	X	X	X	X	X	X	X
UPCE0	X	X	X	X	X	X	X	X	X
UPCE1	O	D	O	O	O	O	O	O	O
US4state	O	--	O	O	O	O	O	--	O
US4state FICS	O	--	O	O	O	O	O	--	O
US Planet	O	--	O	O	O	O	O	--	O
US Postnet	O	--	O	O	O	O	O	--	O

Touch  to return to the previous screen.

## Decoder Params

Use **Decode Params** to configure individual decoder parameters.



**NOTE:** Not all parameter options are available with all scanners. See the DataWedge app on each device for the available scanners and parameter options.

### Codabar

- **CLSI Editing** - Enable this parameter to strip the start and stop characters and insert a space after the first, fifth, and tenth characters of a 14-character Codabar symbol. Enable this feature if the host system requires this data format (default - disabled).
- **Length1** - Use to set decode lengths (default - 6). See Decode Lengths for more information.
- **Length2** - Use to set decode lengths (default - 55). See Decode Lengths for more information.
- **NOTIS Editing** - Enable this parameter to strip the start and stop characters from a decoded Codabar symbol. Enable this feature if the host system requires this data format (default - disabled).
- **Redundancy** - Sets the reader to read the barcode twice before accepting data. A check in the checkbox indicates that redundancy is enabled (default - enabled).

### Code 11

- **Length1** - Use to set decode lengths (default - 4). See Decode Lengths for more information.
- **Length2** - Use to set decode lengths (default - 55). See Decode Lengths for more information.
- **Redundancy** - Sets the reader to read the barcode twice before accepting data. A check in the checkbox indicates that redundancy is enabled (default - enabled).
- **Report Check Digit** - Transmit Code 11 data with or without the check digit. A check in the checkbox indicates to send Code 11 data with check digit (default - disabled).
- **Verify Check Digit** - Check the integrity of all Code 11 symbols to verify that the data complies with the specified check digit algorithm. This selects the check digit mechanism for the decoded Code 11 barcode.
  - **No Check Digit** - Do not verify check digit.
  - **1 Check Digit** - Barcode contains one check digit (default).
  - **2 Check Digits** - Barcode contains two check digits.

### Code128

- **Code128 Reduced Quiet Zone** - Enables decoding of margin-less Code 128 barcodes (default - disabled).
- **Ignore Code128 FNC4** - When enabled, and a Code 128 barcode has an embedded FNC4 character, it will be removed from the data and the following characters will not be changed. When the feature is disabled, the FNC4 character will not be transmitted but the following character will have 128 added to it (default - disabled).
- **Check ISBT Table** - The ISBT specification includes a table that lists several types of ISBT barcodes that are commonly used in pairs. If ISBT128 Concat Mode is set, enable Check ISBT Table to concatenate only those pairs found in this table. Other types of ISBT codes are not concatenated. A check in the checkbox indicates that redundancy is enabled (default - disabled).
- **Enable GS1-128** - Set the GS1 128 subtype. A check in the checkbox indicates that the option is enabled (default - enabled).
- **Enable ISBT128** - Set the ISBT128 subtype. A check in the checkbox indicates that the option is enabled (default - enabled).
- **Enable Plain Code128** - Set the Plain Code128 subtype. Enables other (non-EAN or ISBT) Code 128 subtypes. A check in the checkbox indicates that the option is enabled (default - enabled).

- **ISBT128 Concatenation Mode** - Select an option for concatenating pairs of ISBT code types:
  - **Concat Mode Never** - Do not concatenate pairs of ISBT codes encountered (default).
  - **Concat Mode Always** - There must be two ISBT codes in order to decode and perform concatenation. Does not decode single ISBT symbols.
  - **Concat Mode Auto** - Decodes and concatenates pairs of ISBT codes immediately. If only a single ISBT symbol is present, the device must decode the symbol the number of times set via DataWedge Configuration 4 - 11 Redundancy - Code128 before transmitting its data to confirm that there is no additional ISBT symbol.
- **Length1** - Use to set decode lengths (default - 0). See Decode Lengths for more information.
- **Length2** - Use to set decode lengths (default - 55). See Decode Lengths for more information.
- **Redundancy** - Sets the reader to read the barcode twice before accepting data. A check in the checkbox indicates that redundancy is enabled (default - disabled).
- **Security Level** - The scanner offers four levels of decode security for Code 128 barcodes. Select increasing levels of security for decreasing levels of barcode quality. There is an inverse relationship between security and scanner aggressiveness, so choose only that level of security necessary for any given application.
  - **Security Level 0** - This setting allows the scanner to operate in its most aggressive state, while providing sufficient security in decoding most "in-spec" barcodes.
  - **Security Level 1** - This setting eliminates most misdecodes (default).
  - **Security Level 2** - Select this option if Security level 1 fails to eliminate misdecodes.
  - **Security Level 3** - If Security Level 2 is selected and misdecodes still occur, select this security level. Be advised, selecting this option is an extreme measure against mis-decoding severely out of spec barcodes. Selecting this level of security significantly impairs the decoding ability of the scanner. If this level of security is needed, try to improve the quality of the barcodes.

### Code39

- **Code39 Reduced Quiet Zone** - Enables decoding of margin-less Code 39 barcodes (default - disabled).
- **Convert Code39 To Code32** - Code 32 is a variant of Code 39 used by the Italian pharmaceutical industry. Scan the appropriate barcode below to enable or disable converting Code 39 to Code 32 (default - disabled).
- **Full ASCII**- Code 39 Full ASCII is a variant of Code 39 that pairs characters to encode the full ASCII character set. To enable or disable Code 39 Full ASCII (default - disabled),
- **Length1** - Use to set decode lengths (default - 0). See Decode Lengths for more information.
- **Length2** - Use to set decode lengths 4 (default - 55). See Decode Lengths for more information.
- **Redundancy** - Sets the reader to read the barcode twice before accepting data. A check in the checkbox indicates that redundancy is enabled (default - disabled).
- **Report Check Digit** - Transmit Code 39 data with or without the check digit. A check in the checkbox indicates to send Code 39 data with check digit (default - disabled).
- **Report Code32 Prefix** - Scan the appropriate barcode to enable or disable adding the prefix character "A" to all Code 32 barcodes (default - disabled).

- **Security Level** - Options: **Security level 0**, **Security Level 1**, **Security Level 2** and **Security Level 3** (default - Security level 1).
  - **Security Level 0** - This setting allows the scanner to operate in its most aggressive state, while providing sufficient security in decoding most “in-spec” barcodes.
  - **Security Level 1** - This setting eliminates most misdecodes (default).
  - **Security Level 2** - Select this option if Security level 1 fails to eliminate misdecodes.
  - **Security Level 3** - If Security Level 2 is selected and misdecodes still occur, select this security level. Be advised, selecting this option is an extreme measure against mis-decoding severely out of spec barcodes. Selecting this level of security significantly impairs the decoding ability of the scanner. If this level of security is needed, try to improve the quality of the barcodes.
- **Verify Check Digit** - Enable this feature to check the integrity of all Code 39 symbols to verify that the data complies with a specified check digit algorithm. The digital scanner decodes only those Code 39 symbols that include a modulo 43 check digit. Enable this feature only if the Code 39 symbols contain a modulo 43 check digit (default - disabled).

### Code93

- **Length1** - Use to set decode lengths (default - 0). See Decode Lengths for more information.
- **Length2** - Use to set decode lengths (default - 55). See Decode Lengths for more information.
- **Redundancy** - Sets the reader to read the barcode twice before accepting data. A check in the checkbox indicates that redundancy is enabled (default - disabled).

### Composite AB

- **UCC Link Mode**
  - **Link Flag ignored** - 1D component is transmitted regardless of whether a 2D component is detected.
  - **Always Linked** - 1D and the 2D components are transmitted. If 2D is not present, the 1D component is not transmitted.
  - **Auto Discriminate** - the digital scanner determines if there is a 2D portion, then transmits the 1D component, as well as the 2D portion if present. (default).

### Discrete 2 of 5

- **Length1** - Use to set decode lengths (default - 0). See Decode Lengths for more information.
- **Length2** - Use to set decode lengths (default - 14). See Decode Lengths for more information.
- **Redundancy** - Sets the reader to read the barcode twice before accepting data. A check in the checkbox indicates that redundancy is enabled (default - enabled).

### Grid Matrix

- **Inverse** - Specify the reflectance for decoding Grid Matrix barcodes.
  - **Disabled (0)** - Decode Grid Matrix barcodes with normal reflectance only.
  - **Enabled (1)** - Decode Grid Matrix barcodes with inverse reflectance only.
  - **Auto (2)** - Decodes both normal and inverse reflectance Grid Matrix barcodes. (default - enabled).
- **Mirror** - Specify whether mirrored Grid Matrix barcodes are decoded.
  - **Disabled (0)** - Decode non-mirrored Grid Matrix barcodes only.
  - **Enabled (1)** - Decode mirrored Grid Matrix barcodes only.
  - **Auto (2)** - Decodes both mirrored and non-mirrored Grid Matrix barcodes. (default - enabled).

**GS1 DataBar Limited**

- **GS1 Limited Security Level**

- **GS1 Security Level 1** - This setting allows the scanner to operate in its most aggressive state, while providing sufficient security in decoding most “in-spec” barcodes.
- **GS1 Security Level 2** - This setting eliminates most misdecodes (default).
- **GS1 Security Level 3** - Select this option if Security level 2 fails to eliminate misdecodes.
- **GS1 Security Level 4** - If Security Level 3 is selected and misdecodes still occur, select this security level. Be advised, selecting this option is an extreme measure against mis-decoding severely out of spec barcodes. Selecting this level of security significantly impairs the decoding ability of the scanner. If this level of security is needed, try to improve the quality of the barcodes.

**HAN XIN**

- **HAN XIN Inverse**

- **Disable** - Disables decoding of HAN XIN inverse barcodes (default).
- **Enable** - Enables decoding of HAN XIN inverse barcodes.
- **Auto** - Decodes both HAN XIN regular and inverse barcodes.

**Interleaved 2 of 5**

- **Check Digit**

- **No Check Digit** - A check digit is not used. (default)
- **USS Check Digit** - Select to check the integrity of all Interleaved 2 of 5 symbols to verify the data complies with either the Uniform Symbology Specification (USS) check digit algorithm.
- **OPCC Check Digit** - Select to check the integrity of all Interleaved 2 of 5 symbols to verify the data complies with either the Optical Product Code Council (OPCC) check digit algorithm.
- **Length1** - Use to set decode lengths (default - 14). See Decode Lengths for more information.
- **Length2** - Use to set decode lengths (default - 10). See Decode Lengths for more information.
- **Redundancy** - Sets the reader to read the barcode twice before accepting data. A check in the checkbox indicates that redundancy is enabled (default - enabled).
- **Report Check Digit** - Transmit Interleaved 2 of 5 data with or without the check digit. A check in the checkbox indicates to send Interleaved 2 of 5 data with check digit (default - disabled).
- **I2of5 Security Level** - Options: **I2of5 Security level 0**, **I2of5 Security Level 1**, **I2of5 Security Level 2** and **I2of5 Security Level 3** (default - I2of5 Security level 1).
- **Convert ITF-14 To EAN13** - Convert 14-character Interleaved 2 of 5 barcodes to EAN-13, and transmit as EAN-13. The Interleaved 2 of 5 barcode must be enabled and must have a leading zero and a valid EAN-13 check digit. A check in the checkbox indicates that the option is enabled (default - disabled).
- **I2of5 Reduced Quiet Zone** - Enables decoding of margin-less I2of5 barcodes (default - disabled).

**Matrix 2 of 5**

- **Length1** - Use to set decode lengths (default - 10). See Decode Lengths for more information.
- **Length2** - Use to set decode lengths (default - 0). See Decode Lengths for more information.
- **Redundancy** - Sets the reader to read the barcode twice before accepting data. A check in the checkbox indicates that redundancy is enabled (default - disabled).
- **Report Check Digit** - Transmit Matrix 2 of 5 data with or without the check digit. A check in the checkbox indicates to send Matrix 2 of 5 data with check digit (default - enabled).
- **Verify Check Digit** - Enable this feature to check the integrity of all Matrix 2 of 5 symbols to verify that the data complies with a specified check digit algorithm (default - enabled).

**MSI**

- **Check Digit** - With MSI symbols, one check digit is mandatory and always verified by the reader. The second check digit is optional.
  - **One Check Digit** - Verify one check digit (default).
  - **Two Check Digits** - Verify two check digits.
- **Check Digit Scheme** - Two algorithms are possible for the verification of the second MSI check digit. Select the algorithm used to encode the check digit.
  - **Mod-11-10** - First check digit is MOD 11 and second check digit is MOD 10 (default).
  - **Mod-10-10** - Both check digits are MOD 10.
- **Length 1** - Use to set decode lengths (default - 4). See Decode Lengths for more information.
- **Length 2** - Use to set decode lengths (default - 55). See Decode Lengths for more information.
- **Redundancy** - Sets the reader to read the barcode twice before accepting data. A check in the checkbox indicates that redundancy is enabled (default - enabled).
- **Report Check Digit** - Transmit MSI data with or without the check digit. A check in the checkbox indicates to send MSI data with check digit (default - disabled).

**Trioptic 39**

- **Redundancy** - Sets the reader to read the bar code twice before accepting data. A check in the checkbox indicates that redundancy is enabled (default - disabled).

**UK Postal**

- **Report Check Digit** - Transmit UK Postal data with or without the check digit. A check in the checkbox indicates to send UK Postal data with check digit (default - disabled).

**UPCA**

- **Preamble** - Preamble characters are part of the UPC symbol consisting of Country Code and System Character. Select the appropriate option to match the host system.  
There are three options for transmitting a UPCA preamble:
  - **Preamble None** - Transmit no preamble.
  - **Preamble Sys Char** - Transmit System Character only (default).
  - **Preamble Country and Sys Char** - Transmit System Character and Country Code ("0" for USA). Select the appropriate option to match the host system.
- **Report Check Digit** - The check digit is the last character of the symbol used to verify the integrity of the data. Enables or disables this option. A check in the checkbox indicates that the option is enabled (default - enabled).

**UPCE0**

- **Convert UPCE0 To UPCA** - Enable to convert UPCE0 (zero suppressed) decoded data to UPC-A format before transmission. After conversion, the data follows UPC-A format and is affected by UPC-A programming selections. Disable to transmit UPCE0 decoded data as UPCE0 data, without conversion (default - disabled).

- **Preamble** - Preamble characters are part of the UPC symbol consisting of Country Code and System Character. Select the appropriate option to match the host system.  
There are three options for transmitting a UPCE0 preamble:
  - **Preamble None** - Transmit no preamble (default).
  - **Preamble Sys Char** - Transmit System Character only.
  - **Preamble Country and Sys Char** - Transmit System Character and Country Code (“0” for USA).
- **Report Check Digit** - The check digit is the last character of the symbol used to verify the integrity of the data. Enables or disables this option. A check in the checkbox indicates that the option is enabled (default - disabled).

### UPCE1

- **Convert UPCE1 To UPCA** - Enable this to convert UPCE1 decoded data to UPC-A format before transmission. After conversion, the data follows UPC-A format and is affected by UPC-A programming selections. Disable this to transmit UPCE1 decoded data as UPCE1 data, without conversion (default - disabled).
- **Preamble** - Preamble characters are part of the UPC symbol consisting of Country Code and System Character. Select the appropriate option to match the host system.  
There are three options for transmitting a UPCE1 preamble:
  - **Preamble None** - Transmit no preamble (default).
  - **Preamble Sys Char** - Transmit System Character only.
  - **Preamble Country and Sys Char** - Transmit System Character and Country Code (“0” for USA).
- **Report Check Digit** - The check digit is the last character of the symbol used to verify the integrity of the data. Enables or disables this option. A check in the checkbox indicates that the option is enabled (default - disabled).

### US Planet

- **Report Check Digit** - The check digit is the last character of the symbol used to verify the integrity of the data. Enables or disables this option. A check in the checkbox indicates that the option is enabled (default - disabled).

### Decode Lengths

The allowable decode lengths are specified by options **Length1** and **Length2** as follows:

- Variable length: Decode symbols containing any number of characters.
  - Set both **Length1** and **Length2** to 0.
- Range: Decode a symbol with a specific length range (from *a* to *b*, including *a* and *b*).
  - Set **Length1** to *a* and set **Length2** to *b*.
- Two Discrete Lengths: Decode only symbols containing either of two selected lengths.
  - Set both **Length1** or **Length2** to the specific lengths. **Length1** must be greater than **Length2**.
- One Discrete Length: Decode only symbols containing a specific length.
  - Set both **Length1** and **Length2** to the specific length.

### UPC EAN Params

Allows the configuration of the parameters that apply to more than one UPC or EAN decoder.



**NOTE:** Not all parameter options are available with all scanners. See the DataWedge app on each device for the available scanners and parameter options.

- **Convert DataBar To UPC EAN** - If this is set it converts DataBar barcodes to UPC/EAN format. For this setting to work UPC/EAN symbologies must be enabled. A check in the checkbox indicates that the option is enabled. (default - disabled).
- **UPC Reduced Quiet Zone** - Enables decoding of margin-less UPC barcodes. (default - disabled)
- **Bookland** - Enable Bookland decoding. A check in the checkbox indicates that the option is enabled. (default - disabled).
- **Bookland Format** - If Bookland EAN is enabled, select one of the following formats for Bookland data:
  - **Format ISBN-10** - The decoder reports Bookland data starting with 978 in traditional 10-digit format with the special Bookland check digit for backward-compatibility. Data starting with 979 is not considered Bookland in this mode. (default)
  - **Format ISBN-13** - The decoder reports Bookland data (starting with either 978 or 979) as EAN-13 in 13-digit format to meet the 2007 ISBN-13 protocol.
- **Coupon** - Enables Coupon code decoding. Note that in order to successfully decode Coupon codes, all of the correct decoders must be enabled. A check in the checkbox indicates that the option is enabled. (default - disabled).
- **Coupon Report Mode** - Traditional coupon symbols are composed of two barcode: UPC/EAN and Code 128. A new coupon symbol is composed of a single Data Expanded barcode. The new format offers more options for purchase values (up to \$999.999) and supports complex discount offers as a second purchase requirement. An interim coupon symbol also exists that contain both types of barcodes: UPC/EAN and Databar Expanded. This format accommodates both retailers that do not recognize or use the additional information included in the new coupon symbol, as well as those who can process new coupon symbols.
  - **Old Coupon Report Mode** - Scanning an old coupon symbol reports both UPC and Code 128, scanning an interim coupon symbol reports UPC, and scanning a new coupon symbol reports nothing (no decode).
  - **New Coupon Report Mode** - Scanning an old coupon symbol reports either UPC or Code 128, and scanning an interim coupon symbol or a new coupon symbol reports Databar Expanded.
  - **Both Coupon Report Modes** - Scanning an old coupon symbol reports both UPC and Code 128, and scanning an interim coupon symbol or a new coupon symbol reports Databar Expanded. (default)
- **Ean Zero Extend** – Enable this parameter to add five leading zeros to decoded EAN-8 symbols to make them compatible in format to EAN-13 symbols. Disable this to transmit EAN-8 symbols as is. Default – disabled.
- **Linear Decode** - This option applies to code types containing two adjacent blocks, for example, UPC-A, EAN-8, EAN-13. Enable this parameter to transmit a bar code only when both the left and right blocks are successfully decoded within one laser scan. Enable this option when bar codes are in proximity to each other (default - enabled).
- **Retry Count** - Retry count for auto-discriminating for supplementals. Possible values are 2 to 20 inclusive. Note that this flag is only considered if Supplemental Mode - UPC EAN is set to one of the following values: **Supplementals Auto, Supplementals Smart, Supplementals 378-379, Supplementals 978-979, Supplementals 977** or **Supplementals 414-419-434-439** (2 to 20, default 10).



- **Security Level** - The scanner offers four levels of decode security for UPC/EAN barcodes. Select higher security levels for lower quality barcodes. There is an inverse relationship between security and decode speed, so be sure to choose only that level of security necessary for the application.
  - **Level 0** - This default setting allows the scanner to operate fastest, while providing sufficient security in decoding “in-spec” UPC/EAN barcodes.
  - **Level 1** - As barcode quality levels diminish, certain characters become prone to misdecodes before others (i.e., 1, 2, 7, 8). If the scanner is misdecoding poorly printed barcodes, and the misdecodes are limited to these characters, select this security level. (default).
  - **Level 2** - If the scanner is misdecoding poorly printed barcodes, and the misdecodes are not limited to characters 1, 2, 7, and 8, select this security level.
  - **Level 3** - If the scanner is still misdecoding, select this security level. Be advised, selecting this option is an extreme measure against misdecoding severely out of spec barcodes. Selecting this level of security can significantly impair the decoding ability of the scanner. If this level of security is necessary, try to improve the quality of the barcodes.
- **Supplemental2** - Enables or disables this option. A check in the checkbox indicates that the option is enabled.
- **Supplemental5** - Enables or disables this option. A check in the checkbox indicates that the option is enabled.
- **Supplemental Mode**
  - **No Supplementals** - the scanner is presented with a UPC/EAN plus supplemental symbol, the scanner decodes UPC/EAN and ignores the supplemental characters (default).
  - **Supplemental Always** - the scanner only decodes UPC/EAN symbols with supplemental characters, and ignores symbols without supplementals.
  - **Supplementals Auto** - the scanner decodes UPC/EAN symbols with supplemental characters immediately. If the symbol does not have a supplemental, the scanner must decode the barcode the number of times set via UPC/EAN Supplemental Redundancy before transmitting its data to confirm that there is no supplemental.
  - **Supplemental Smart** - Enables smart supplementals. In this mode the decoder returns the decoded value of the main block right away if it does not belong to one of the following supplemental types: 378, 379, 977, 978, 979, 414, 419, 434 or 439. If the barcode starts with one of the prefixes it searches the image more aggressively for a supplemental. Tries to scan the supplemental if it is present. If the supplemental scanning failed, then the main barcode is returned.
  - **Supplemental 378-379** - Enables (auto-discriminate) supplemental for UPC/EAN codes starting with 378 or 379. Disables reading of supplementals for any other UPC/EAN barcode not starting with 378 or 379. Tries to scan the supplemental if it is present. If the supplemental scanning failed, then the main barcode is returned.
  - **Supplemental 978-979** - Enables (auto-discriminate) supplemental for UPC/EAN codes starting with 978 or 979. Disables reading of supplementals for another UPC/EAN barcode not starting with 978 or 979. Tries to scan the supplemental if it is present. If the supplemental scanning failed, then the main barcode is returned.
  - **Supplemental 414-419-434-439** - Enables (auto-discriminate) supplemental for UPC/EAN codes starting with 414, 419, 434 or 439. Disables reading of supplementals for another UPC/EAN barcode 4 - 16 not starting with 414, 419, 434 or 439. Tries to scan the supplemental if it is present. If the supplemental scanning failed, then the main barcode is returned.
  - **Supplemental 977** - Enables (auto-discriminate) supplemental for UPC/EAN codes starting with 977. Disables reading of supplementals for another UPC/EAN barcode not starting with 977. Tries to scan the supplemental if it is present. If the supplemental scanning failed, then the main barcode is returned.

## Reader Params

Allows the configuration of parameters specific to the selected barcode reader.



**NOTE:** Not all parameter options are available with all scanners. See the DataWedge app on each device for the available scanners and parameter options.

- **Character Set Configuration** - Used to support the GB2312 Chinese characters encoding.
  - **Character Set Selection** - Allows the user to convert the barcode data if different from default encoding type.
    - **Auto Character Set Selection (Best Effort)** - Automatic character convert option. Tries to decode data from the Preferred selection. The first correct decodable character set is used to convert the data and is sent.
    - **ISO-8859-1** - Part of the ISO/IEC 8859 series of ASCII-based standard character encodings. It is generally intended for Western European languages.
    - **Shift\_JIS** - Shift Japanese Industrial Standards (JIS) is a character encoding for the Japanese language.
    - **GB18030** - Chinese coded character set that defines the required language and character support necessary for software in China.
    - **UTF-8** - A character encoding capable of encoding all possible characters, or code points, defined by Unicode (default).
  - **Auto Character Set Preferred Order** - In **Auto Character Set Selection** mode, the system will try to decode the data in a preference order of character sets. The algorithm used is a best effort one. That is, there could be cases where the data can be decoded from more than one character set. The first character set from the preferred list which can decode the data successfully will be chosen to decode the data and sent to the user. Any other character set that is in the list but lower in the preferred order, would not be considered, even if the data could be successfully decoded using such character set.
 

The preferred character set and its preference order is configurable to the user through the **Auto Character Set Preferred Order** menu. Users can change the order by dragging the icon for that menu item. To delete an item, long press on an item and the **Delete** option will appear. To add a new item, tap the menu icon at top right corner and options to add UTF-8 and GB2312 will appear.

    - **UTF-8** - A character encoding capable of encoding all possible characters, or code points, defined by Unicode (default).
    - **GB2312** - Character set of the People's Republic of China, used for simplified Chinese characters.
  - **Auto Character Set Failure Option** - If the system cannot find a character set from the preferred list that can be used to successfully decode the data, the character set selected in **Auto Character Set Failure Option** is used to decode the data and send to the user. If **NONE** is used, Null data is returned as string data.
    - **NONE**
    - **UTF-8** - A character encoding capable of encoding all possible characters, or code points, defined by Unicode (default).
    - **ISO-8859-1** - Part of the ISO/IEC 8859 series of ASCII-based standard character encodings. It is generally intended for Western European languages.
    - **Shift\_JIS** - ended for Western European languages.
    - **Shift\_JIS** - Shift Japanese Industrial Standards (JIS) is a character encoding for the Japanese language.
    - **GB18030** - Chinese coded character set that defines the required language and character support necessary for software in China.
- **1D Quiet Zone Level** - Sets the level of aggressiveness in decoding barcodes with a reduced quiet zone (the area in front of and at the end of a barcode), and applies to symbologies enabled by a Reduced Quiet

Zone parameter. Because higher levels increase the decoding time and risk of misdecodes, Zebra strongly recommends enabling only the symbologies which require higher quiet zone levels, and leaving Reduced Quiet Zone disabled for all other symbologies.

Options are:

- **0** - The scanner performs normally in terms of quiet zone.
- **1** - The scanner performs more aggressively in terms of quiet zone (default).
- **2** - The scanner only requires one side EB (end of barcode) for decoding.
- **3** - The scanner decodes anything in terms of quiet zone or end of barcode.
- **Adaptive Scanning** - When adaptive scanning is enabled, the scan engine toggles between wide and narrow, allowing the scan engine to decode barcodes based on the distance.
  - **Disable**
  - **Enable** (default).
- **Beam Width** - Beam Width is applicable only with linear scanners.
  - **Narrow**
  - **Normal** (default)
  - **Wide**
- **Aim mode** - Turns the scanner cross-hairs on or off.
  - **On** - Cross-hair is on (default).
  - **Off** - Cross-hair is off.
- **Aim Timer** - Sets the maximum amount of time that aiming remains on (0 - 60,000 ms in increments of 100 ms). A value of 0 sets the aim to stay on indefinitely (default - 500).
- **Aim Type** - Set the aiming usage.
  - **Trigger** - A trigger event activates decode processing, which continues until the trigger event ends or a valid decode occurs (default).
  - **Timed Hold** - A trigger pull and hold activates the laser for aiming, which continues until the trigger is released, a valid decode, or the decode session time-out is expired.
  - **Timed Release** - A trigger pull activates the laser for aiming, which continues until a valid decode or the remaining decode session time has expired.
  - **Press and Release** - A trigger pull and release activates the laser for aiming, which continues until a trigger is pressed again, a valid decode, or the decode session time-out is expired.
  - **Presentation** - Automatically activates the scanner and starts scanning immediately when a barcode is presented in its field of view, without any trigger press.
  - **Continuous Read** - When the imager detects an object in its field of view, it triggers and attempt to decode.
  - **Press and Sustain** - Starts the scan beam when the trigger is pressed and continues the decode session until the Beam Timer is expired, barcode is decoded or read is canceled. Scan beam is not stopped when the trigger is released. This avoids unexpected cancellations of a read by subsequently pressing the trigger button of the device; subsequent trigger presses while the beam is ON have no effect.
- **Beam Timer** - Sets the maximum amount of time that the reader remains on (0 - 60,000 ms in increments of 100 ms). A value of 0 sets the reader to stay on indefinitely (default -5000).
- **Time Delay to Low Power** - Sets the time the decoder remains active after decoding. After a scan session, the decoder waits this amount of time before entering Low Power Mode. Options: **1 Second** (default), **30 Seconds**, **1 Minute** or **5 Minutes**.
- **Different Symbol Timeout** - Controls the time the scanner is inactive between decoding different symbols. Programmable in 500 msec increments from 0 to 5 seconds. The default is 500 msec.

- **DPM External Illumination** - Controls illumination for DPM barcodes.
- **Direct** - Scanner uses only direct (white) illumination. Recommended for use with dot peen barcodes - tilt the part 30 degrees for optimal decoding.
- **Indirect** - Scanner uses only red illumination. Recommended for use with laser etched barcodes on cylinders or curved, rough, grainy, highly reflective, or visibly machined surfaces.
- **Cycle (default)**- Scanner cycles alternately between direct and indirect illumination. The scanner starts with the illumination used during the last successful decode.
- **DPM Mode** - Mode to optimize DPM barcode decoding performance based on barcode size (Default value is Mode 2).
- **Disabled** - No special processing.
- **Mode 1**- Optimizes decoding performance for smaller DPM barcodes, typically found on electronics and medical instruments, especially on smooth surfaces. These barcodes tend to be laser etched or direct printed.
- **Mode 2 (default)** - Optimizes decoding performance for larger DPM barcodes, typically found on industrial parts, especially on rough, grainy or visibly machined surface. These barcodes tend to be dot peen or laser etched.
- **DPM Illumination Control** - Controls illumination for DPM barcodes: (default - Cycle Illumination).
  - **Direct Illumination** - Scanner uses only direct (white) illumination. Recommended for use with dot peen barcodes - tilt the part 30 degrees for optimal decoding.
  - **Indirect Illumination** - Scanner uses only red illumination. Recommended for use with laser etched barcodes on cylinders or curved, rough, grainy, highly reflective, or visibly machined surfaces.
  - **Cycle Illumination** - Scanner cycles alternately between direct and indirect illumination. The scanner starts with the illumination used during the last successful decode.
- **DMP Mode** - Mode to optimize DPM barcode decoding performance based on barcode size (default - DPM Mode 2).
  - **Disabled** - No special processing.
  - **DPM Mode 1** - Optimizes decoding performance for smaller DPM barcodes, typically found on electronics and medical instruments, especially on smooth surfaces. These barcodes tend to be laser etched or direct printed.
  - **DPM Mode 2** - Optimizes decoding performance for larger DPM barcodes, typically found on industrial parts, especially on rough, grainy or visibly machined surface. These barcodes tend to be dot peen or laser etched.
- **Digimarc Decoding** - Enables/disables support for Digimarc, which encodes and invisibly integrates traditional barcode data onto product packaging. Supported with internal imager only. (default - Enabled).
- **Illumination Brightness** - Sets the brightness of the illumination by altering LED power. The default is 10, which is maximum LED brightness. For values from 1 to 10, LED brightness varies from lowest to highest level of brightness.
- **Illumination mode** - Turns imager illumination on and off. This option is only available when **Bluetooth Scanner** is selected in the **Barcode input, Scanner selection** option.
  - **Off** - Illumination is off.
  - **On** - Illumination is on (default).
- **Inverse 1D Mode** - This parameter allows the user to select decoding on inverse 1D barcodes.
  - **Disable** - Disables decoding of inverse 1D barcodes (default).
  - **Enable** - Enables decoding of only inverse 1D barcodes.
  - **Auto** - Allows decoding of both twice positive and inverse 1D barcodes.

- **Keep Pairing Info After Reboot**
  - **Disable** - Disables the ability to keep pairing info after reboot.
  - **Enable** - Enables the ability to keep pairing info after reboot. (default).
- **LCD Mode** - Enables or disables LCD mode. LCD mode enhances the ability of the imager to read barcodes from LCD displays such as cellphones.
  - **Disable** - Disables the LCD mode (default).
  - **Enable** - Enables LCD mode.
- **Linear Security Level** - Sets the number of times a barcode is read to confirm an accurate decode.
  - **Security Short or Codabar** - Two times read redundancy if short barcode or Codabar (default).
  - **Security All Twice** - Two times read redundancy for all barcodes.
  - **Security Long and Short** - Two times read redundancy for long barcodes, three times for short barcodes.
  - **Security All Thrice** - Three times read redundancy for all barcodes.
- **HW Engine Low Power Timeout** - Time (0 - 1,000 ms in increments of 50 ms) of inactivity before scanner enters low-power mode from (default - 250)..
- **Picklist** - Allows the imager to decode only the barcode that is directly under the cross-hair/reticle (+) part of the pattern. This feature is useful in applications where multiple barcodes may appear in the field of view during a decode session and only one of them is targeted for decode.
  - **Disabled** – Disables Picklist mode. Any barcode within the field of view can be decoded (default).
  - **Enabled** – Enables Picklist mode so that only the barcode under the projected reticle can be decoded.
- **Poor Quality Decode Effort** - Enable poor quality barcode decoding enhancement feature.
- **Same Symbol Timeout** - Controls the time the scanner is inactive between decoding same symbols. Programmable in 500 msec increments from 0 to 5 seconds. The default is 500 msec.
- **Scanning Modes** - Scanning options available on the device.
  - **Single** - Set to scan general barcodes (default).
  - **UDI** - Set to scan healthcare specific barcodes.
  - **MultiBarcode** - Set to scan multiple barcodes. When this option is selected, the **Multibarcodes params** can be set to read from 2 to 10 barcodes on a single scan.

## Scan Params

Allows the configuration of Code ID and decode feedback options.



**NOTE:** Not all parameter options are available with all scanners. See the DataWedge app on each device for the available scanners and parameter options.

- **Code ID Type** - A Code ID character identifies the code type of a scanned barcode. This is useful when the reader is decoding more than one code type. Select a code ID character to insert between the prefix and the decoded symbol.
  - **Code ID Type None** - No prefix (default)
  - **Code ID Type AIM** - Insert AIM Character prefix.
  - **Code ID Type Symbol** - Insert Symbol character prefix.
- **Engine Decode LED** - Use to turn on scanner red LED when the scan beam is emitting either by scanner trigger or using soft scan button.
- **BT Disconnect On Exit** - Bluetooth connection is disconnected when data capture application is closed .
- **Connection Idle Time** - Set connection idle time. The Bluetooth connection disconnects after being idle for set time.

- **Display BT Address Barcode** - Enable or disable displaying Bluetooth Address bar code if there is no Bluetooth scanner being paired when application tries to enable the Bluetooth scanner.
- **Establish Connection Time** - The timeout which the device will try to enable or reconnect to the Bluetooth scanner when the Bluetooth scanner is not in the vicinity or not paired.
- **Audio Feedback Mode** - Select good decode audio indication.
  - **Local Audio Feedback** - Good decode audio indication on device only.
  - **Remote Audio Feedback** - Good decode audio indication.
  - **Both** - Good decode audio indication on device and scanner (default).
  - **Disable** - No good decode audio indication on either device or scanner.
- **LED Feedback Mode** - Select good decode LED indication.
  - **Local LED Feedback** - Good decode LED indication on device only.
  - **Remote LED Feedback** - Good decode LED indication on scanner.
  - **Both** - Good decode LED indication on device and scanner (default).
  - **Disable** - No good decode LED indication on either device or scanner.
- **Decode Audio Feedback** - Select an audio tone to sound upon a good decode (default optimized-beep).
- **Decode Screen Notification** - Select to enable the display of a one second translucent green screen overlay as a notification for each successful decode. Default - disabled.



**NOTE:** For **Decode Screen Notification** to work, **Display over other apps** permission must be granted for the application.

- **Decode Screen Notification Timer** - Set the amount of time (in milliseconds) that the green decode screen stays lit (500 - 1500). (default - 1000).
- **Decode Screen Translucency Level** - Set the level of translucency for the green decode screen (20 - 50). (default - 35).
- **Decoding LED Notification** - Enable the device to light the red Data Capture LED when data capture is in progress. (default - disabled).
- **Decode Feedback LED Timer** - Set the amount of time (in milliseconds) that the green Data Capture LED stays lit after a good decode. (default - 75 msec.)
- **Beep Volume Control** - Set the good decode beep to a system or other sound. This allows for independent control of the good beep volume.



**NOTE:** Not all ringtones are fully supported as decode tones and those of longer length may be truncated when used as a decode tone. The recommendation is to test the selected tone for operation before deployment to a customer site.

- **Ringer** - Set the good decode beep to the ringer sound.
- **Music and Media** - Set the good decode beep to the media sound.
- **Alarms** - Set the good decode beep to the alarm sound.
- **Notifications** - Set the good decode beep to the notification sound (default).

## UDI Params

Allows the configuration of parameters specific to healthcare barcodes.

- **Enable UDI-GSI** - Enable UDI using GS1 standards (default - enabled).
- **Enable UDI-HIBCC** - Enable UDI using HIBCC standards (default - enabled).
- **Enable UDI-ICCBBA** - Enable UDI using ICCBBA standards (default - enabled).

## Multibarcodes params

Set the number of barcodes that the device can read on a single scan from 2 to 10. Must also enable **Reader Params > Scanning Modes > MultiBarcode** option.

## Keep enabled on suspend

Keep Bluetooth scanner enabled after suspend (default-disabled).

## Voice Input

Zebra GMS devices have a built in Google speech recognition engine. By making use of the speech engine capabilities, DataWedge has extended automated data capturing to user applications through voice. Currently, DataWedge does not capture data for Voice Input.

Voice data capturing starts after you speak the predefined start phrase and it stops after you speak the data or speak the end phrase, if one was defined.



### IMPORTANT:

- Simultaneous use of Voice Input in DataWedge and Google Voice is not supported.
- Voice Input is not supported if the Enterprise Home Screen (EHS) is in restricted mode. However, enabling all of the privilege settings in EHS reinstates Voice Input.
- Voice Input is not supported if the device language is changed to another language, for example Chinese.

Use **Voice Input** to configure the Voice Input Plug-in.

- **Enabled** - Enables or disables this plug-in. A check in the checkbox indicates that the plug-in is enabled.
- **Data capture start phrase** - Starts data capture with the phrase entered in this field. This field is mandatory. (Default - **start**).  
Providing numbers and other special characters as the data capture start phrase is not supported.
- **Data capture end phrase** - Ends data capture with the phrase entered in this field or keep it blank if not required. This field is not mandatory. (Default - Blank).
- **Tab command** - Enables the Tab command, which sends a tab key when the user speaks the command **send tab**. The commands are supported only when the device is at the **waiting for start phrase** state.
- **Enter command** - Enables the Enter command, which sends an enter key when the user speaks the command **send enter**. The commands are supported only when the device is at the **waiting for start phrase** state.
- **Data type** - Allows the user to configure the data type. Set the data type to limit the data capture according to the preferences specified. Available options:
  - **Any** - Scanning a barcode of ABC123, returns ABC123.
  - **Alpha** - Scanning a barcode of ABC123, returns ABC only.
  - **Numeric** - Scanning a barcode of ABC, returns 123 only.
- **Start phrase waiting tone** - Enables or disables this option. Enables audio feedback for **waiting for start**. This option notifies the user that the device is waiting to start the speech engine if you miss the toast message and the **waiting for start** state changes.
- **Data capture waiting tone** - Enables or disables this option. Enables audio feedback for **waiting for data**. This option notifies the user that the device is waiting to capture data if you miss the toast message.

- **Validation window** - Enables or disables the **Validate captured data** window. Enable this option to validate the result that you speak. The window displays the data spoken and the data can be edited on the same screen if any modification is needed. This is very useful when used with the offline mode.

Editing in the Validation window is not supported if Keystroke Input is enabled in the profile where Voice Input is enabled.

- **Offline speech recognition** - Enables or disables speech recognition. Enable this option to use Voice Input when you do not have access to the Internet. This option uses an offline recognition speech engine to detect the data you speak.

## Keystroke Output

DataWedge supports Keystroke Output, which collects the processed data and sends it to the foreground application as a series of keystrokes which helps data capturing to applications without writing any code. DataWedge sends captured data via intents, where user applications can consume them in their applications without worrying about the complexities to write code to capture the data.

Use to configure the Keystroke Output Plug-in for the profile.

- **Enabled** — Enables or disables this plug-in. A check in the checkbox indicates that the plug-in is enabled (default - enabled).
- **Action key character** - Enables decoding of a special character embedded within a barcode data for use in native Android applications. This feature is helpful when populating or executing a form.
  - **None** - Action key character feature is disabled (default).
  - **Tab** - Tab character code in a barcode is processed. When DataWedge detects this character code in a barcode, move the focus to the next field.
  - **Line feed** - Line feed character code in a barcode is processed. When DataWedge detects this character code in a barcode, move the focus to the next field.
  - **Carriage return** - Carriage return character code in a barcode is processed. When DataWedge detects this character code in a barcode, move the focus to the next field.
- **Inter character delay** - Set the delay between keystrokes (in milliseconds).
- **Delay Multibyte characters only** - If Inter character delay is set, enable Delay Multibyte characters only to delay only the multibyte characters.
- **Key event delay** - Set the amount of time (in milliseconds) of the wait time for control characters. (default - 0.)
- **Data formatting and ordering** - Allows formatting and ordering of UDI and Multibarcodes data.
  - **UDI specific** - Allows the output order of acquired UDI data to be adjusted and the optional insertion of a tab, line feed, or carriage return character between tokens.
    - **Send tokens** - Set to select the output format for UDI data. (default - disabled)
    - **Token separator** - Set to select a separator character. If no separator character is selected when Send tokens is set to Barcodes and tokens, two instances of the same data are sent. (default - none)
    - **Token order** - Set to include or exclude Tokens from the output and adjust their output order.
  - **Multibarcodes specific** - Allows the optional insertion of a tab, line feed, or carriage return between each barcode.
    - **Barcode separator** - Set to select a separator character. If no separator character is selected, the data set is sent as a single string.



- **Advanced data formatting** - is a way to customizing data before transmission. Use advanced data formatting (ADF) to edit scan data to suit requirements.
  - **Enable** - Enables or disables ADF. A check in the checkbox indicates that ADF is enabled (default - disabled).
  - **Rules** - ADF uses rules to customize data. These rules perform detailed actions when the data meets certain criteria. One rule may consist of single or multiple criteria applied to single or multiple actions. See [Generating Advanced Data Formatting Rules on page 111](#) for more information.
- **Basic data formatting** - Allows the configuration of any data formatting for the related Output Plug-in. When the plug-in is disabled, any data is passed on without modification.
  - **Enabled** - Enables or disables Basic Data Formatting. A check in the checkbox indicates that it is enabled (default - enabled).
  - **Prefix to data** - Add characters to the beginning of the data when sent.
  - **Suffix to data** - Add characters to the end of the data when sent.
  - **Send data** - Set to transfer the captured data to the foreground application. Disabling this option prevents the actual data from being transmitted. However, the prefix and suffix strings, if present, are still transmitted even when this option is disabled (default - enabled).
  - **Send as hex** - Set to send the data in hexadecimal format. A check in the checkbox indicates that the plug-in is enabled (default - disabled).
  - **Send TAB key** - Set to append a tab character to the end of the processed data. A check in the checkbox indicates that the plug-in is enabled (default - disabled).
  - **Send ENTER key** - Set to append an Enter character to the end of the processed data. A check in the checkbox indicates that the plug-in is enabled (default - disabled).

## Intent Output

Allows configuration of the Intent Output Plug-in for the profile. The Intent Output Plug-in allows the captured data to be sent to an application in the form of an implicit Intent. Refer to the Android Developer web site for more information, [developer.android.com](http://developer.android.com).

- **Enabled** - Enables or disables this plug-in. A check in the checkbox indicates that the plug-in is enabled (default - disabled).
- **Intent action** - Enter the Intent Action name (required).
- **Intent category** - Enter the Intent Category name (required).
- **Intent delivery** - Select the method by which the intent is delivered:
  - Send via StartActivity
  - Send via startService (default)
  - Broadcast intent
- **Receiver foreground flag** - Set Broadcast intent flag in Intent delivery. (DS3678).
- **Advanced data formatting** - is a way to customizing data before transmission. Use advanced data formatting (ADF) to edit scan data to suit requirements.
  - **Enable** - Enables or disables ADF. A check in the checkbox indicates that ADF is enabled (default - disabled).
  - **Rules** - ADF uses rules to customize data. These rules perform detailed actions when the data meets certain criteria. One rule may consist of single or multiple criteria applied to single or multiple actions. See [Generating Advanced Data Formatting Rules on page 111](#) for more information.

- **Basic data formatting** - Allows configuration of any data formatting for the related Output Plug-in. When the plug-in is disabled any data is passed on without modification.
  - **Enabled** - Enables or disables Basic Data Formatting. A check in the checkbox indicates that it is enabled (default - enabled).
  - **Prefix to data** - Add characters to the beginning of the data when sent.
  - **Suffix to data** - Add characters to the end of the data when sent.
  - **Send data** - Set to transfer the captured data to the foreground application. Disabling this option prevents the actual data from being transmitted. However, the prefix and suffix strings, if present, are still transmitted even when this option is disabled (default - enabled).
  - **Send as hex** - Set to send the data in hexadecimal format. A check in the checkbox indicates that the plug-in is enabled (default - disabled).
  - **Send TAB key** - Set to append a tab character to the end of the processed data. A check in the checkbox indicates that the plug-in is enabled (default - disabled).
  - **Send ENTER key** - Set to append an Enter character to the end of the processed data. A check in the checkbox indicates that the plug-in is enabled (default - disabled).

## Intent Overview

The core components of an Android application (its activities, services, and broadcast receivers) are activated by intents. An intent is a bundle of information (an Intent object) describing a desired action - including the data to be acted upon, the category of component that should perform the action, and other pertinent instructions. Android locates an appropriate component to respond to the intent, launches a new instance of the component if one is needed, and passes it the Intent object.

Components advertise their capabilities, the kinds of intents they can respond to, through intent filters. Since the system must learn which intents a component can handle before it launches the component, intent filters are specified in the manifest as `<intent-filter>` elements. A component may have any number of filters, each one describing a different capability. For example, if the manifest contains the following:

```
<intent-filter . . . >
<action android:name="android.intent.action.DEFAULT" />
<category android:name="android.intent.category.MAIN" />
</intent-filter>
```

In the Intent output plug-in configuration, the **Intent action** would be:

```
android.intent.category.DEFAULT
```

and the Intent category would be:

```
android.intent.category.MAIN.
```

The **Intent delivery** option allows the method by which the intent is delivered to be specified. The delivery mechanisms are **Send via startActivity**, **Send via startService** or **Broadcast intent**.

The decode related data added to the Intent's bundle can be retrieved using the `Intent.getStringExtra()` and `Intent.getSerializableExtra()` calls, using the following String tags:

- String LABEL\_TYPE\_TAG = "com.symbol.emdk.datawedge.label\_type";
  - String contains the label type of the barcode.

- String DATA\_STRING\_TAG = “com.symbol.emdk.datawedge.data\_string”;
  - String contains the output data as a String. In the case of concatenated barcodes, the decode data is concatenated and sent out as a single string.
- String DECODE\_DATA\_TAG = “com.symbol.emdk.datawedge.decode\_data”;
  - Decode data is returned as a list of byte arrays. In most cases there will be one byte array per decode. For barcode symbologies that support concatenation, for example, Codabar, Code128, MicroPDF, etc., the decoded data is stored in multiple byte arrays (one byte array per barcode). Clients can get data in each byte array by passing an index.

Most scanning applications might want the user to be able to decode data and for that decode data to be sent to the **\*current\*** activity but not necessarily displayed. If this is the case, then the activity needs to be marked as 'singleTop' in its AndroidManifest.xml file. If your activity is not defined as singleTop, then on every decode, the system will create another copy of your Activity and send the decode data to this second copy.

Finally there will be a configuration option for each process plug-in so that the process plug-in can be configured specifically for the intent output, which in this case is the basic data formatting process plug-in.

## IP Output



**NOTE:** IPWedge application is required on a host computer. Download the IPWedge application from the Support Central web site: [www.zebra.com/support](http://www.zebra.com/support).

IP Output allows DataWedge to send captured data to a host computer via a network connection. Captured data can be sent over an IP network to a specified IP address and port using either TCP or UDP transport protocols.

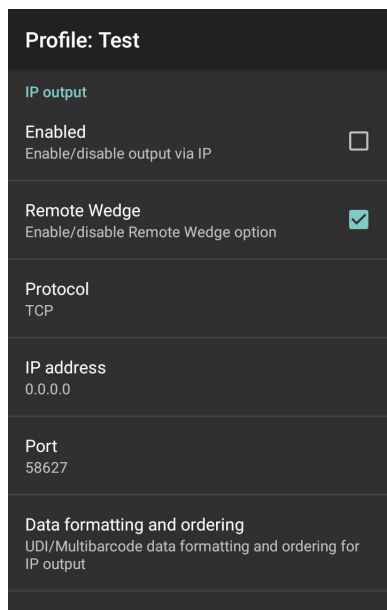
- **Enabled** - Enables or disables this plug-in. A check in the checkbox indicates that the plug-in is enabled (default - disabled).
- **Remote Wedge** - Enable or disable the Remote Wedge option (default - enabled). Remote Wedge is used with the IPWedge application.
- **Protocol** - Select the protocol used by the remote application. Options: **TCP** (default) or **UDP**.
- **IP address** - Enter the IP address used by the remote application (default - 0.0.0.0).
- **Port** - Enter the port number used by the remote application (default - 58627).
- **Data formatting and ordering** - Allows formatting and ordering of UDI and Multibarcodes data.
  - **UDI specific** - Allows the output order of acquired UDI data to be adjusted and the optional insertion of a tab, line feed, or carriage return character between tokens.
    - **Send tokens** - Set to select the output format for UDI data. (default - disabled)
    - **Token separator** - Set to select a separator character. If no separator character is selected when Send tokens is set to Barcodes and tokens, two instances of the same data are sent. (default - none)
    - **Token order** - Set to include or exclude Tokens from the output and adjust their output order.
- **Advanced data formatting** - is a way of customizing data before transmission. Use advanced data formatting (ADF) to edit scan data to suit requirements.
  - **Enable** - Enables or disables ADF. A check in the checkbox indicates that ADF is enabled (default - disabled).
  - **Rules** - ADF uses rules to customize data. These rules perform detailed actions when the data meets certain criteria. One rule may consist of single or multiple criteria applied to single or multiple actions. See [Generating Advanced Data Formatting Rules on page 111](#) for more information.

- **Basic data formatting** - Allows configuration of any data formatting for the related Output Plug-in. When the plug-in is disabled any data is passed on without modification.
  - **Enabled** - Enables or disables Basic Data Formatting. A check in the checkbox indicates that it is enabled (default - enabled).
  - **Prefix to data** - Add characters to the beginning of the data when sent.
  - **Suffix to data** - Add characters to the end of the data when sent.
  - **Send data** - Set to transfer the captured data to the foreground application. Disabling this option prevents the actual data from being transmitted. However, the prefix and suffix strings, if present, are still transmitted even when this option is disabled (default - enabled).
  - **Send as hex** - Set to send the data in hexadecimal format. A check in the checkbox indicates that the plug-in is enabled (default - disabled).
  - **Send TAB key** - Set to append a tab character to the end of the processed data. A check in the checkbox indicates that the plug-in is enabled (default - disabled).
  - **Send ENTER key** - Set to append an Enter character to the end of the processed data. A check in the checkbox indicates that the plug-in is enabled (default - disabled).

## Usage

This section provides information on how to configure IP Output using the DataWedge configuration user interface. To use IP Output in a particular DataWedge profile (for example: **Profile0**), scroll downward on **IP Output**.

Figure 12 IP Output Screen



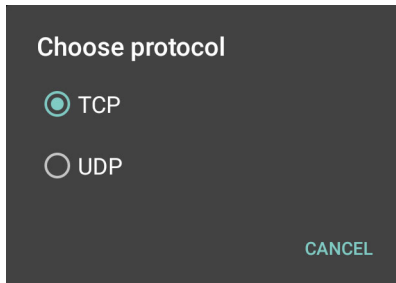
## Using IP Output with IPWedge

IPWedge is a computer application that can be easily configured to retrieve data sent over network by DataWedge IP Output. Refer to the IPWedge User Manual on how to install and configure in a host computer. To enable IP Output to send captured data to a remote computer that is installed with IPWedge:

1. In **IP Output**, touch **Enabled**.  
A check appears in the checkbox.

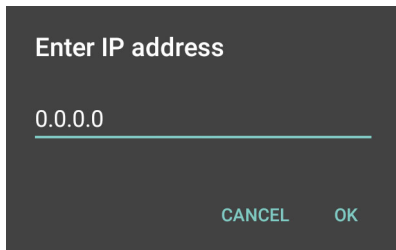
2. Ensure **Remote Wedge** option is enabled.
3. Touch **Protocol**.
4. In the **Choose protocol** dialog box, touch the same protocol selected for the IPWedge computer application. (TCP is the default).

Figure 13 Protocol Selection



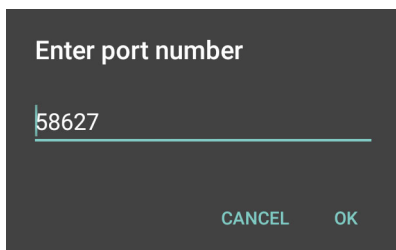
5. Touch **IP Address**.
6. In the **Enter IP Address** dialog box, enter the IP address of host computer to send data to.

Figure 14 IP Address Entry



7. Touch **Port**.
8. In the **Enter port number** dialog box, enter same port number selected for IPWedge computer application.

Figure 15 Port Number Entry



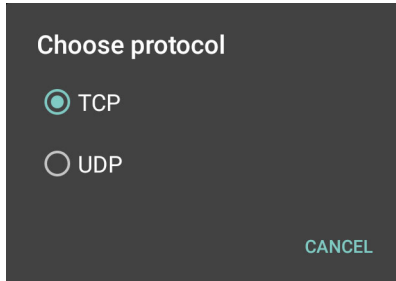
9. Configure **Advanced data formatting** and **Basic data formatting** Plug-in if any required modification to be done to captured data before sending to remote computer.

## Using IP Output without IPWedge

IP Output Plug-in can be used to send captured data from DataWedge to a remote device or host computer without using IPWedge. At the data receiving end, the host computer or mobile device should have an application, that listens to TCP or UDP data coming from a configured port and IP address in the IP Output plug-in. To enable IP Output to send captured data to a remote computer:

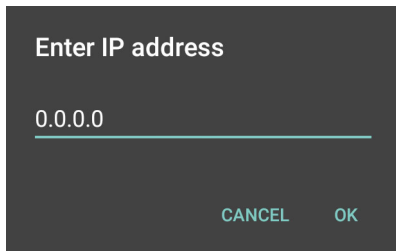
1. In **IP Output**, touch **Enabled**.  
A check appears in the checkbox.
2. Ensure **Remote Wedge** option is disabled.
3. Touch **Protocol**.
4. In the **Choose protocol** dialog box, touch the same protocol selected in the client application. (TCP is the default).

Figure 16 Protocol Selection



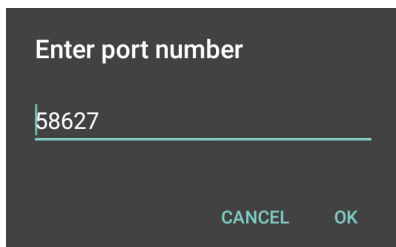
5. Touch **IP Address**.
6. In the **Enter IP address** dialog box, enter the IP address of host computer to send data to.

Figure 17 IP Address Entry



7. Touch **Port**.
8. In the **Enter port number** dialog box, enter the port number that the host computer application is listening on.

Figure 18 Port Number Entry



9. Configure **Advanced Data Formatting** and **Basic Data Formatting** Plug-in if any required modification to be done to captured data before sending to remote computer.

## Generating Advanced Data Formatting Rules

The ADF plug-in applies rules (actions to be performed based on defined criteria) to the data received via an input plug-in before sending it to the output plug-in.

- **Rules** - The ADF process plug-in consists of one or more rules. DataWedge formats the output data according to the first matching rule. A rule is a combination of criteria and a set of actions to be performed, upon fulfillment of the criteria set in the rule.
- **Criteria** - Criteria can be set according to Input plug-in, symbology, matching string within the data (at the specified position) and/or data length. Received data must match the defined criteria in order for the data to be processed.
- **Actions** - A set of procedures defined to format data. There are four types of actions which are for formatting cursor movement, data modification, data sending and delay specifications. An action can be defined to send the first number of characters to the Output plug-in, pad the output data with spaces or zeros, remove spaces in data, etc.

## Configuring ADF Plug-in

Configuring the ADF plug-in consists of creating a rule, defining the criteria and defining the actions.


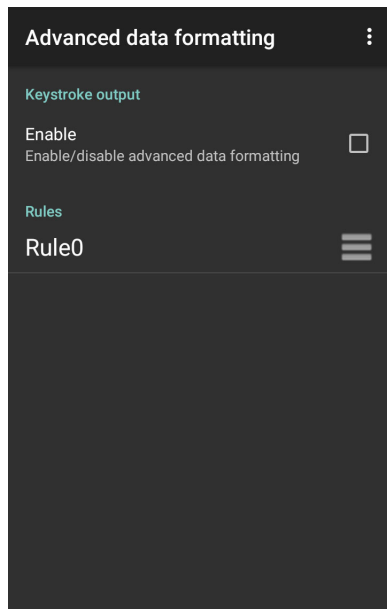
1. Swipe up from the bottom of the screen and touch .
2. Touch a DataWedge profile.
3. In **Keystroke Output**, touch **Advanced data formatting**.

Figure 19 Advanced Data Formatting Screen



4. Touch the **Enable** checkbox to enable ADF.

## Creating a Rule



**NOTE:** By default, **Rule0**, is the only rule in the Rules list.

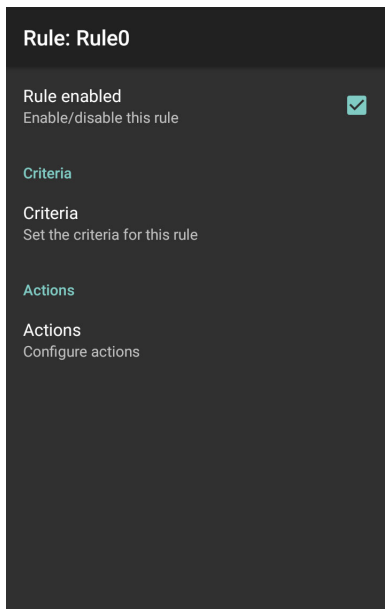
1. Touch .

2. Touch **New rule**.
3. Touch the **Enter rule name** text box.
4. In the text box, enter a name for the new rule.
5. Touch **OK**.

## Defining a Rule

1. Touch the newly created rule in the **Rules** list.

Figure 20 Rule List Screen



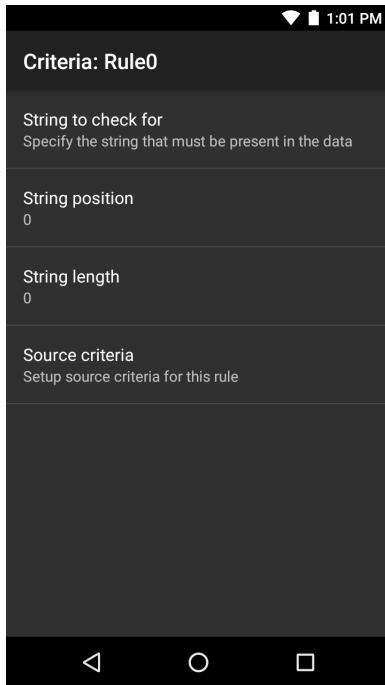
2. Touch the **Rule enabled** check box to enable the current rule.

## Defining Criteria

1. Touch **Criteria**.

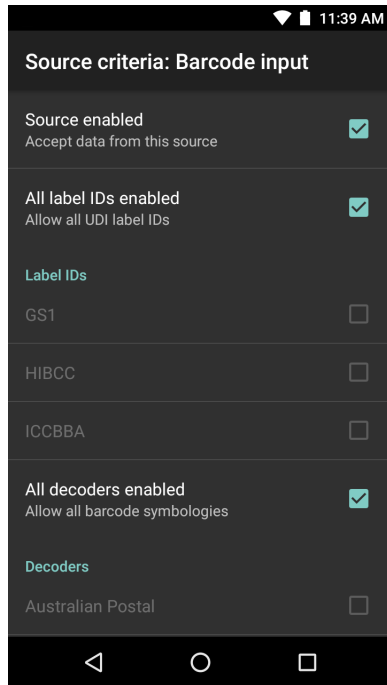




Figure 21 Criteria Screen



2. Touch **String to check for** option to specify the string that must be present in the data.
3. In the **Enter the string to check for** dialog box, enter the string
4. Touch **OK**.
5. Touch **String position** option to specify the position of the string specified in the **String to check for** option. The ADF rule is only applied if the specific string in **String to check for** is found at the specified **String position** location (zero for the start of the string).
6. Touch the **+** or **-** to change the value.
7. Touch **OK**.
8. Touch **String length option** to specify a length for the received data. The ADF rule only applies to the barcode data with that specified length.
9. Touch the **+** or **-** to change the value.
10. Touch **OK**.
11. Touch **Source criteria** option to associate an input device to an ADF rule. The ADF rule only applies to data received from associated input devices.
12. Touch **Barcode input**. Options vary depending upon the device configuration.
13. Touch the **Source enabled** checkbox to accept data from this source.

Figure 22 Barcode Input Screen






14. For general barcode inputs, touch the **All decoders enabled** checkbox to select all bar code symbologies. Deselect the **All decoders enabled** checkbox to individually select the symbologies.
15. Touch  until the **Rule** screen appears.
16. If required, repeat steps to create another rule.
17. Touch  until the Rule screen appears.

## Defining an Action



**NOTE:** By default the **Send remaining** action is in the **Actions** list.

1. Touch .
2. Touch **New action**.
3. In the **New action** menu, select an action to add to the **Actions** list. See [Table 2 on page 115](#) for a list of supported ADF actions.
4. Some Actions require additional information. Touch the Action to display additional information fields.
5. Repeat steps to create more actions.
6. Touch .
7. Touch .

## Deleting a Rule

1. Touch and hold on a rule until the context menu appears.
2. Touch **Delete rule** to delete the rule from the **Rules** list.



**NOTE:** When there is no rule available for ADF plug-in or all rules are disabled, DataWedge passes decoded data to the

output plug-in without processing the data.

## Order Rules List



**NOTE:** When there are no rules defined, ADF passes the captured data through as is. In contrast, when rules are defined but all are disabled, ADF does not pass any captured data through.

Rules are processed in top-down order. The rules that are on top of the list are processed first. Use the icon next to the rule to move it to another position in the list.

*Table 2 ADF Supported Actions*

Type	Actions	Description
Cursor Movement	Skip ahead	Moves the cursor forward by a specified number of characters. Enter the number of characters to move the cursor ahead.
	Skip back	Moves the cursor back by a specified number of characters. Enter the number of characters to move the cursor back.
	Skip to start	Moves the cursor to the beginning of the data.
	Move to	Moves the cursor forward until the specified string is found. Enter the string in the data field.
	Move past a	Moves the cursor forward past the specified string. Enter the string in the data field.
Data Modification	Crunch spaces	Remove spaces between words to one and remove all spaces at the beginning and end of the data.
	Stop space crunch	Stops space crunching. This disables the last <b>Crunch spaces</b> action.
	Remove all spaces	Remove all spaces in the data.
	Stop space removal	Stop removing spaces. This disables the last <b>Remove all spaces</b> action.
	Remove leading zeros	Remove all zeros at the beginning of data.
	Stop zero removal	Stop removing zeros at the beginning of data. This disables the previous <b>Remove leading zeros</b> action.
	Pad with zeros	Left pad data with zeros to meet the specified length. Enter the number zeros to pad.
	Stop pad zeros	Stop padding with zeros. This disables the previous <b>Pad with zeros</b> action.
	Pad with spaces	Left pad data with spaces to meet the specified length. Enter the number spaces to pad.
	Stop pad spaces	Stop padding with spaces. This disables the previous <b>Pad with spaces</b> action.
	Replace string	Replaces a specified string with a new string. Enter the string to replace and the string to replace it with.
	Stop all replace string	Stop all <b>Replace string</b> actions.

Table 2 ADF Supported Actions (Continued)

Type	Actions	Description
Data Sending	Send next	Sends the specified number of characters from the current cursor position. Enter the number of characters to send.
	Send remaining	Sends all data that remains from the current cursor position.
	Send up to	Sends all data up to a specified string. Enter the string.
	Send pause	Pauses the specified number of milliseconds before continuing the next action. Enter the amount of time in milliseconds.
	Send string	Sends a specified string. Enter the string to send.
	Send char	Sends a specified ASCII/ Unicode character. Enter a character value. The maximum Unicode character value can be entered is U-10FFFF (= 1114111 in decimal).

## Deleting an Action

1. Touch and hold the action name.
2. Select **Delete action** from the context menu.

## ADF Example

The following illustrates an example of creating Advanced Data Formatting:


When a user scans a barcode with the following criteria:







- Code 39 barcode.
- length of 12 characters.
- contains 129 at the start position.

Modify the data as follows:

- Pad all sends with zeros to length 8.
- send all data up to character X.
- send a space character.

To create an ADF rule for the above example:

1. Swipe up from the bottom of the screen and touch .
2. Touch **Profile0**.
3. Under **Keystroke Output**, touch **Advanced data formatting**.
4. Touch **Enable**.
5. Touch **Rule0**.
6. Touch **Criteria**.
7. Touch **String to check for**.
8. In the **Enter the string to check for** text box, enter 129 and then touch **OK**.
9. Touch **String position**.

10. Change the value to 0.
11. Touch **OK**.
12. Touch **String length**.
13. Change value to 12.
14. Touch **OK**.
15. Touch **Source criteria**.
16. Touch **Barcode input**.
17. Touch **All decoders enabled** to disable all decoders.
18. Touch **Code 39**.
19. Press  three times.
20. Touch **Actions**.
21. Touch and hold on the **Send remaining rule** until a menu appears.
22. Touch **Delete action**.
23. Touch .
24. Touch **New action**.
25. Select **Pad with zeros**.
26. Touch the **Pad with zeros** rule.
27. Touch **How many**.
28. Change value to 8 and then touch **OK**.
29. Press .
30. Touch .
31. Touch **New action**.
32. Select **Send up to**.
33. Touch **Send up to** rule.
34. Touch **String**.
35. In the **Enter a string** text box, enter x.
36. Touch **OK**.
37. Touch .
38. Touch .
39. Touch **New action**.
40. Select **Send char**.
41. Touch **Send char** rule.
42. Touch **Character code**.

43. In the **Enter character code** text box, enter 32.

44. Touch **OK**.


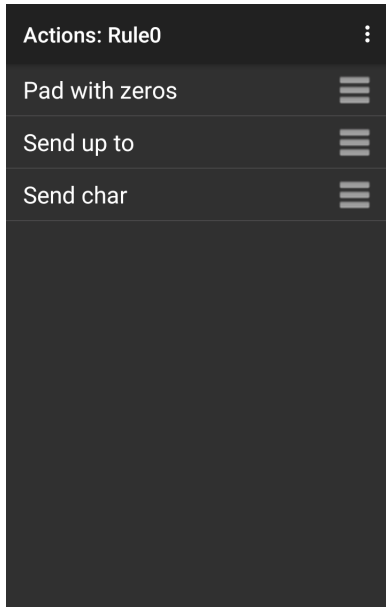
45. Touch .

Figure 23 ADF Sample Screen



46. Ensure that an application is open on the device and a text field is in focus (text cursor in text field).

47. Aim the exit window at the barcode.

Figure 24 Sample Barcode



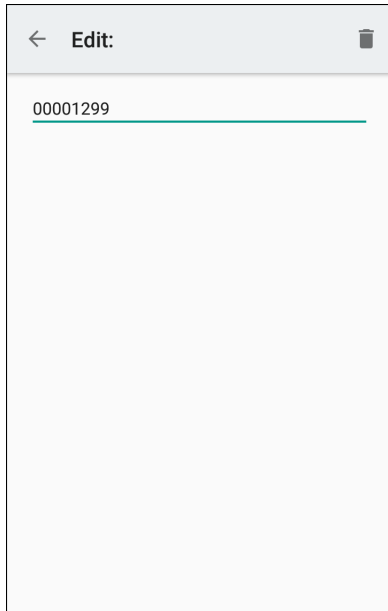
48. Press and hold the scan button.

The red laser aiming pattern turns on to assist in aiming. Ensure that the barcode is within the area formed by the aiming pattern. The LED light red to indicate that data capture is in process.

49. The LED lights green, a beep sounds and the device vibrates, by default, to indicate the barcode was decoded successfully. The LED lights green and a beep sounds, by default, to indicate the barcode was decoded successfully. The formatted data 000129X<space>appears in the text field.

Scanning a Code 39 barcode of 1299X15598 does not transmit data (rule is ignored) because the barcode data did not meet the length criteria.

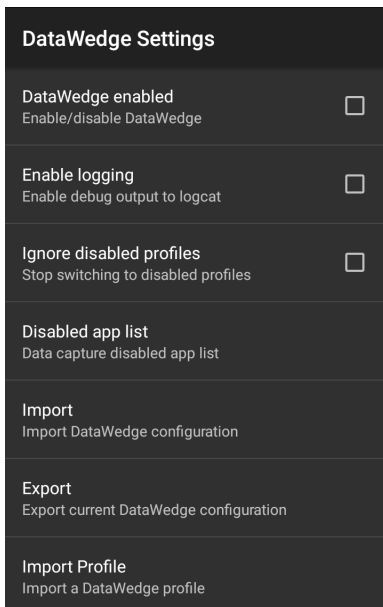
Figure 25 Formatted Data



## DataWedge Settings

The DataWedge Settings screen provides access to general, non-profile related options. Touch  > **Settings**.



Figure 26 DataWedge Settings Window



- **DataWedge enabled** - Enables or disables DataWedge. To disable DataWedge uncheck this option (default - enabled).
- **Enable logging** - Enables or disables debug output file to logcat. To enable logging check this option (default - disabled).



- **Ignore disabled profiles** - Prevents DataWedge from switching to a Profile that is not enabled. In such instances, the Profile switch is ignored and the current Profile remains active Profile0 must be disabled to use this feature (default - disabled).
- **Disable app list** - Disables scanning functions for selected applications or activities.
- **Import** - Allows import of a DataWedge configuration file. The imported configuration replaces the current configuration.
- **Export** - Allows export of the current DataWedge configuration.
- **Import Profile** - Allows import of a DataWedge profile file.
- **Export Profile** - Allows export of a DataWedge profile.
- **Restore** - Return the current configuration back to factory defaults.
- **Reporting** - Configures reporting options.

### Importing a Configuration File

1. Copy the configuration file to the microSD card `/Android/data/com.symbol.datawedge/files` folder.
2. Swipe up from the bottom of the screen and touch .
3. Touch .
4. Touch **Settings**.
5. Touch **Import**.
6. Touch **filename to import**.

The configuration file (datawedge.db) is imported and replaces the current configuration.



### Exporting a Configuration File

1. Swipe up from the bottom of the screen and touch .
2. Touch .
3. Touch **Settings**.
4. Touch **Export**.
5. In the **Export to** dialog box, select the location to save the file.
6. Touch **Export**. The configuration file (datawedge.db) is saved to the selected location.

### Importing a Profile File





**NOTE:** Do not change the filename of the of the profile file. If the filename is changed, the file will not be imported.

1. Copy the profile file to the On Device Storage `/Android/data/com.symbol.datawedge/files` folder.
2. Swipe up from the bottom of the screen and touch .
3. Touch .
4. Touch **Settings**.
5. Touch **Import Profile**.





6. Touch the profile file to import.
7. Touch **Import**. The profile file (**dwprofile\_x.db**, where x = the name of the profile) is imported and appears in the profile list.

## Exporting a Profile

1. Swipe up from the bottom of the screen and touch .
2. Touch .
3. Touch **Settings**.
4. Touch **Export Profile**.
5. Touch the profile to export.
6. Touch **Export**.  
The profile file (dwprofile\_x.db, where x = name of the profile) is saved to the root of the On-device Storage.

## Restoring DataWedge

To restore DataWedge to the factory default configuration:

1. Swipe up from the bottom of the screen and touch .
2. Touch .
3. Touch **Settings**.
4. Touch **Restore**.
5. Touch **Yes**.

## Configuration and Profile File Management

The configuration or profile settings for DataWedge can be saved to a file for distribution to other devices.

After making configuration or profile changes, export the new configuration or profile to the root of the On-device Storage. The configuration file created is automatically named datawedge.db. The profile file created is automatically named dwprofile\_x.db, where x is the profile name. The files can then be copied to the On-device Storage of other devices and imported into DataWedge on those devices. Importing a configuration or profile replaces the existing settings.

## Enterprise Folder

Internal storage contains the Enterprise folder (**/enterprise**). The Enterprise folder is persistent and maintains data after an Enterprise reset. After an Enterprise Reset, DataWedge checks folder **/enterprise/device/settings/datawedge/enterprisereset/** for a configuration file, datawedge.db or a profile file, dwprofile\_x.db. If the file is found, it imports the file to replace any existing configuration or profile.



**NOTE:** A Factory Reset deletes all files in the Enterprise folder.

## Auto Import

DataWedge supports remote deployment of a configuration to a device, using tools such as commercially available third-party Mobile Device Management (MDM) systems. DataWedge monitors the `/enterprise/device/settings/datawedge/autoimport` folder for the DataWedge configuration file (datawedge.db) or a profile file (dwprofile\_x.db). When DataWedge launches it checks the folder. If a configuration or profile file is found, it imports the file to replace any existing configuration or profile. Once the file has been imported it is deleted from the folder.

While DataWedge is running it receives a notification from the system that a file has been placed into the `/enterprise/device/settings/datawedge/autoimport` folder. When this occurs, DataWedge imports this new configuration or profile, replacing the existing one and delete the file. DataWedge begins using the imported configuration immediately.



**NOTE:** A Factory Reset deletes all files in the `/enterprise` folder.

It is strongly recommended that the user exits DataWedge before remotely deploying any configuration or profile. It is required that the file permissions are set to 666.

The `/enterprise` folder cannot be seen with **Files** app or other user-level tools. Moving configuration files to and from the `/autoimport` or `/enterprisereset` folders must be done programmatically, or with a staging client app or MDM.

## Reporting

DataWedge 6.6 (and higher) can report the results of the importation of device Profiles. These HTML reports display settings differences between the originating (source) database and the target (destination) device. This allows administrators to easily identify differences and make adjustments to compensate for disparities in hardware or software capabilities from one device to another. Reports always use the destination device as the basis against which to compare incoming settings files.

## Programming Notes

The following paragraphs provide specific programming information when using DataWedge.

### Overriding Trigger Key in an Application

To override the trigger key in an application, create a profile for the application that disables the Barcode input. In the application, use standard APIs, such as `onKeyDown()` to listen for the `KEYCODE_BUTTON_L1` and `KEYCODE_BUTTON_R1` presses.

### Capture Data and Taking a Photo in the Same Application

To be able to capture bar code data and take a photo in the same application:

- Create a Datawedge profile pertaining to the picture taking Activity in your application that disables scanning and use standard Android SDK APIs to control the Camera.
- The default Datawedge profile takes care of the scanning in the application. You might want to create another DataWedge profile that caters to any specific scanning needs, associated to your Application's Activity pertaining to scanning.

## Disable DataWedge on Device and Mass Deploy

To disable DataWedge and deploy onto multiple devices:

1. Swipe up from the bottom of the Home screen and touch **DataWedge**.
2. Touch **⋮**.
3. Touch **Settings**.
4. Unselect the **DataWedge enabled** check box.
5. Export the DataWedge configuration. See [Exporting a Configuration File on page 120](#) for instructions. See [Configuration and Profile File Management on page 121](#) for instructions for using the auto import feature.

## DataWedge APIs

DataWedge APIs operate primarily through Android intents - specific commands that can be used by other applications to control data capture without the need to directly access the DataWedge UI.

## Soft Scan Trigger

DataWedge allows a native Android application to programmatically start, stop, or toggle the scan trigger state. The application can issue an Android Broadcast Intent, to control the scanner, without requiring the scan key to be pressed. The active DataWedge profile is required to control all the parameters during a scan operation.

### Function Prototype

```
Intent i = new Intent();
i.setAction("com.symbol.datawedge.api.ACTION");
i.putExtra("com.symbol.datawedge.api.SOFT_SCAN_TRIGGER", "<parameter>");
```

### Parameters

The structure of the broadcast intent that resolves to the soft scan is:

**ACTION** [String]: "com.symbol.datawedge.api.ACTION"

**EXTRA\_DATA** [String]: "com.symbol.datawedge.api.SOFT\_SCAN\_TRIGGER"

**<parameter>**: The parameter as a string, using any of the following:

- **START\_SCANNING** - starts scanning when triggered
- **STOP\_SCANNING** - stops or interrupts scanning when triggered
- **TOGGLE\_SCANNING** - toggles between **START\_SCANNING** and **STOP\_SCANNING** when triggered.

## Scanner Input Plugin

The ScannerInputPlugin API command can be used to enable/disable the scanner plug-in being used by the currently active Profile. Disabling the scanner plug-in effectively disables scanning in that Profile, regardless of

whether the Profile is associated or unassociated. Valid only when Barcode Input is enabled in the active Profile.



**NOTE:** Use of this API changes only the runtime status of the scanner; it does not make persistent changes to the Profile.

## Function Prototype

```
Intent i = new Intent();
i.setAction(ACTION);
i.putExtra(EXTRA_DATA, "<parameter>");
```

## Parameters

**action:** String "com.symbol.datawedge.api.ACTION\_SCANNERINPUTPLUGIN"

**extra\_data:** String "com.symbol.datawedge.api.EXTRA\_PARAMETER"

**<parameter>:** The parameter as a string, using either of the following:

- "ENABLE\_PLUGIN" - enables the plug-in
- "DISABLE\_PLUGIN" - disables the plug-in

## Return Values

None.

Error and debug messages will be logged to the Android logging system which then can be viewed and filtered by the logcat command. You can use logcat from an ADB shell to view the log messages, for example:

```
$ adb logcat -s DWAPI
```

Error messages will be logged for invalid actions and parameters.

## Example

```
// define action and data strings
String scannerInputPlugin = "com.symbol.datawedge.api.ACTION_SCANNERINPUTPLUGIN";
String extraData = "com.symbol.datawedge.api.EXTRA_PARAMETER";

public void onResume() {
    // create the intent
    Intent i = new Intent();
    // set the action to perform
    i.setAction(scannerInputPlugin);
    // add additional info
    i.putExtra(extraData, "DISABLE_PLUGIN");
    // send the intent to DataWedge
    context.this.sendBroadcast(i);
}
```

## Comments

This Data Capture API intent allows the scanner plug-in for the current Profile to be enabled or disabled. For example, activity A launches and uses the Data Capture API intent to switch to ProfileA in which the scanner plug-in is enabled, then at some point it uses the Data Capture API to disable the scanner plug-in. Activity B is launched. In DataWedge, ProfileB is associated with activity B. DataWedge switches to ProfileB. When activity A comes back to the foreground, in the `onResume` method, activity A needs to use the Data Capture API intent to switch back to ProfileA, then use the Data Capture API intent again to disable the scanner plug-in, to return back to the state it was in.



**NOTE:** Use of this API changes only the runtime status of the scanner; it does not make persistent changes to the Profile. The above assumes that ProfileA is not associated with any applications/activities, therefore when focus switches back to activity A, DataWedge will not automatically switch to ProfileA therefore activity A must switch back to ProfileA in its `onResume` method. Because DataWedge will automatically switch Profile when an activity is paused, it is recommended that this API function be called from the `onResume` method of the activity.

## Enumerate Scanners

Use the `enumerateScanners` API command to get a list of scanners available on the device.

### Function Prototype

```
Intent i = new Intent();
i.setAction("com.symbol.datawedge.api.ACTION");
i.putExtra("com.symbol.datawedge.api.ENUMERATE_SCANNERS", "");
```

### Parameters

**ACTION** [String]: "com.symbol.datawedge.api.ENUMERATE\_SCANNERS"

## Return Values

The enumerated list of scanners will be returned via a broadcast Intent. The broadcast Intent action is "com.symbol.datawedge.api.ACTION\_ENUMERATEDSCANNERLIST" and the list of scanners is returned as a string array (see the example below).

Error and debug messages will be logged to the Android logging system which then can be viewed and filtered by the logcat command. You can use logcat from an ADB shell to view the log messages, for example:

```
$ adb logcat -s DWAPI
```

Error messages will be logged for invalid actions and parameters.

## Example

```

//
// Call before sending the enumeration query
//
public void registerReceiver(){
    IntentFilter filter = new IntentFilter();
    filter.addAction("com.symbol.datawedge.api.RESULT_ACTION");//RESULT_ACTION
    filter.addCategory(Intent.CATEGORY_DEFAULT);
    registerReceiver(enumeratingBroadcastReceiver, filter);
}
//
// Send the enumeration command to DataWedge
//
public void enumerateScanners(){
    Intent i = new Intent();
    i.setAction("com.symbol.datawedge.api.ACTION");
    i.putExtra("com.symbol.datawedge.api.ENUMERATE_SCANNERS", "");
    this.sendBroadcast(i);
}

public void unRegisterReceiver(){
    unregisterReceiver(enumeratingBroadcastReceiver);
}

//
// Create broadcast receiver to receive the enumeration result
//
private BroadcastReceiver enumeratingBroadcastReceiver = new BroadcastReceiver() {
    @Override
    public void onReceive(Context context, Intent intent) {
        String action = intent.getAction();
        Log.d(TAG, "Action: " + action);
        if(action.equals("com.symbol.datawedge.api.RESULT_ACTION")){
            //
            // enumerate scanners
            //
            if(intent.hasExtra("com.symbol.datawedge.api.RESULT_ENUMERATE_SCANNERS")) {
                ArrayList<Bundle> scannerList = (ArrayList<Bundle>)
intent.getSerializableExtra("com.symbol.datawedge.api.RESULT_ENUMERATE_SCANNERS");
                if((scannerList != null) && (scannerList.size() > 0)) {
                    for (Bundle bunb : scannerList){
                        String[] entry = new String[4];
                        entry[0] = bunb.getString("SCANNER_NAME");
                        entry[1] = bunb.getBoolean("SCANNER_CONNECTION_STATE")+"";
                        entry[2] = bunb.getInt("SCANNER_INDEX")+"";

                        entry[3] = bunb.getString("SCANNER_IDENTIFIER");

                        Log.d(TAG, "Scanner:" + entry[0] + " Connection:" + entry[1] + " Index:" + entry[2] + " ID:" + entry[3]);
                    }
                }
            }
        }
    }
};

```

## Comments

The scanner and its parameters are set based on the currently active Profile.

## Set Default Profile

Use the `setDefaultProfile` API function to set the specified Profile as the default Profile.

### Default Profile Recap

Profile0 is the generic Profile used when there are no user created Profiles associated with an application.

Profile0 can be edited but cannot be associated with an application. That is, DataWedge allows manipulation of plug-in settings for Profile0 but it does not allow assignment of a foreground application. This configuration allows DataWedge to send output data to any foreground application other than applications associated with user-defined Profiles when Profile0 is enabled.

Profile0 can be disabled to allow DataWedge to only send output data to those applications which are associated in user-defined Profiles. For example, create a Profile associating a specific application, disable Profile0 and then scan. DataWedge only sends data to the application specified in the user-created Profile. This adds additional security to DataWedge enabling the sending of data only to specified applications.

### Usage Scenario

A launcher application has a list of apps that a user can launch and that none of the listed apps has an associated DataWedge Profile. Once the user has selected an app, the launcher needs to set the appropriate DataWedge Profile for the selected app. This could be done by using `setDefaultProfile` to set the default Profile to the required Profile. Then when the user launches the selected app, DataWedge auto Profile switching switches to the default Profile (which is now the required Profile for that app).

If, for some reason, the launched app has an associated DataWedge Profile then that will override the set default Profile.

When control is returned to the launcher application, `resetDefaultProfile` can be used to reset the default Profile.

### Function Prototype

```
Intent i = new Intent();
i.setAction("com.symbol.datawedge.api.ACTION");
i.putExtra("com.symbol.datawedge.api.SET_DEFAULT_PROFILE", "<profile name>");
```

### Parameters

**ACTION** [String]: "com.symbol.datawedge.api.ACTION"

**EXTRA\_DATA** [String]: "com.symbol.datawedge.api.SET\_DEFAULT\_PROFILE"

**<profile name>**: The Profile name (a case-sensitive string) to set as the default Profile.

### Return Values

None.

Error and debug messages will be logged to the Android logging system which then can be viewed and filtered by the `logcat` command. You can use `logcat` from an ADB shell to view the log messages, for example:



```
$ adb logcat -s DWAPI
```

Error messages will be logged for invalid actions, parameters and failures, for example, Profile not found or associated with an application.

## Example

```
// define action and data strings
String setDefaultProfile = "com.symbol.datawedge.api.ACTION";
String extraData = "com.symbol.datawedge.api.SET_DEFAULT_PROFILE";

public void onResume() {
    // create the intent
    Intent i = new Intent();

    // set the action to perform
    i.setAction(setDefaultProfile);

    // add additional info (a name)
    i.putExtra(extraData, "myProfile");

    // send the intent to DataWedge
    this.sendBroadcast(i);
}
```

## Comments

The API command will have no effect if the specified Profile does not exist or if the specified Profile is already associated with an application. DataWedge will automatically switch Profiles when the activity is paused, so it is recommended that this API function be called from the onResume method of the activity.

Zebra recommends that this Profile be created to cater to all applications/activities that would otherwise default to using Profile0. This will ensure that these applications/activities continue to work with a consistent configuration.

## Reset Default Profile

Use the resetDefaultProfile API function to reset the default Profile back to Profile0.

## Function Prototype

```
Intent i = new Intent();
i.setAction("com.symbol.datawedge.api.ACTION");
i.putExtra("com.symbol.datawedge.api.RESET_DEFAULT_PROFILE", "");
```

## Parameters

**ACTION** [String]: "com.symbol.datawedge.api.ACTION"

**EXTRA\_DATA** [String]: "com.symbol.datawedge.api.RESET\_DEFAULT\_PROFILE".

## Return Values

None.

Error and debug messages will be logged to the Android logging system which then can be viewed and filtered by the logcat command. You can use logcat from an ADB shell to view the log messages, for example:

```
$ adb logcat -s DWAPI
```

Error messages will be logged for invalid actions, parameters and failures, for example, Profile not found or associated with an application.

## Example

```
::javascript
// define action string
String action = "com.symbol.datawedge.api.ACTION";
String extraData = "com.symbol.datawedge.api.RESET_DEFAULT_PROFILE";

public void onResume() {
    // create the intent
    Intent i = new Intent();

    // set the action to perform
    i.setAction(action);
    i.putExtra(extraData, ""); // empty since a name is not required
    this.sendBroadcast;
}
```

## Comments

None.

## Switch To Profile

Use the SwitchToProfile API action to switch to the specified Profile.

### Profiles Recap

DataWedge is based on Profiles and plug-ins. A Profile contains information on how DataWedge should behave with different applications.

Profile information consists of:

- Associated application
- Input plug-in configurations
- Output plug-in configurations
- Process plug-in configurations

DataWedge includes a default Profile, Profile0, that is created automatically the first time DataWedge runs.

Using Profiles, each application can have a specific DataWedge configuration. For example, each user application can have a Profile which outputs scanned data in the required format when that application comes to the foreground. DataWedge can be configured to process the same set of captured data differently based on the requirements of each application.



**NOTE:** Use of this API changes only the runtime status of the scanner; it does not make persistent changes to the Profile. A single Profile may be associated with one or many activities/apps, however, given an activity, only one Profile may be associated with it.

### Usage Scenario

An application has two activities. Activity A only requires EAN13 bar codes to be scanned. Activity B only requires Code 128 bar codes to be scanned. Profile EAN13 is configured to only scan EAN13 bar codes and is left unassociated. Profile Code128 is configured to scan Code 128 and is left unassociated. When Activity A launches it uses SwitchToProfile to activate Profile EAN13. Similarly, when Activity B launches it uses switchToProfile to activate Profile Code128.

If another activity/app comes to the foreground, DataWedge auto Profile switching will set the DataWedge Profile accordingly either to the default Profile or to an associated Profile.

When Activity A (or Activity B) comes back to the foreground it will use switchToProfile to reset the Profile back to Profile B (or Profile M).

### Function Prototype

```
Intent i = new Intent();
i.setAction("com.symbol.datawedge.api.ACTION");
i.putExtra("com.symbol.datawedge.api.SWITCH_TO_PROFILE", "<profile name>");
```

### Parameters

**ACTION** [String]: "com.symbol.datawedge.api.ACTION"

**EXTRA\_DATA** [String]: "com.symbol.datawedge.api.SWITCH\_TO\_PROFILE"

**<profile name>**: The Profile name (a case-sensitive string) to set as the active Profile.

## Return Values

None.

Error and debug messages will be logged to the Android logging system which then can be viewed and filtered by the logcat command. You can use logcat from an ADB shell to view the log messages, for example:

```
$ adb logcat -s DWAPI
```

Error messages will be logged for invalid actions, parameters and failures, for example, Profile not found or associated with an application.

## Example

```
// define action and data strings
String switchToProfile = "com.symbol.datawedge.api.ACTION";
String extraData = "com.symbol.datawedge.api.SWITCH_TO_PROFILE";

public void onResume() {
    super.onResume();

    // create the intent
    Intent i = new Intent();

    // set the action to perform
    i.setAction(switchToProfile);

    // add additional info
    i.putExtra(extraData, "myProfile");

    // send the intent to DataWedge
    this.sendBroadcast(i);
}
```

## Comments

This API function will have no effect if the specified Profile does not exist or is already associated with an application.

DataWedge has a one-to-one relationship between Profiles and activities; a Profile can be associated only with a single activity. When a Profile is first created, it's not associated with any application, and will not be activated until associated. This makes it possible to create multiple unassociated Profiles.

This API function activates such Profiles.

For example, Profile A is unassociated and Profile B is associated with activity B. If activity A is launched and uses **SwitchToProfile** function to switch to Profile A, then Profile A will be active whenever activity A is in the foreground. When activity B comes to the foreground, DataWedge will automatically switch to Profile B.

When activity A returns to the foreground, the app must use **SwitchToProfile** again to switch back to Profile A. This would be done in the **onResume** method of activity A.



**NOTE:** Use of this API changes only the runtime status of the scanner; it does not make persistent changes to the Profile.

## Notes

Because DataWedge will automatically switch Profile when the activity is paused, Zebra recommends that this API function be called from the **onResume** method of the activity.

After switching to a Profile, this unassociated Profile does not get assigned to the application/activity and is available to be used in the future with a different app/activity.

For backward compatibility, DataWedge's automatic Profile switching is not affected by the above API commands. This why the commands work only with unassociated Profiles and apps.

DataWedge auto Profile switching works as follows:

Every second...

- Sets **newProfileId** to the associated Profile ID of the current foreground activity.
- If no associated Profile is found, sets **newProfileId** to the associated Profile ID of the current foreground app.
- If no associated Profile is found, sets **newProfileId** to the current default Profile (which MAY NOT be Profile0).
- Checks the **newProfileId** against the **currentProfileId**. If they are different:
  - deactivates current Profile
  - activates new Profile (**newProfileId**)
  - sets **currentProfileId** = **newProfileId**


# Settings

## Introduction

This chapter describes settings available for configuring the device.

## Setting Screen Lock

Use the **Device security** settings to set preferences for locking the screen.

1. Swipe down from the Status bar to open the Quick Access panel and then touch .
2. Touch **Security & location**.



**NOTE:** Options vary depending upon the policy of some apps, such as email.

- **Screen lock** - Touch to configure the device to require a slide, pattern, PIN, or password to unlock the screen.
  - **None** - Disable screen unlock security.
  - **Swipe** - Slide the lock icon to unlock the screen.
  - **Pattern** - Draw a pattern to unlock screen. See [Setting Screen Unlock Using Pattern on page 136](#) for more information.
  - **PIN** - Enter a numeric PIN to unlock screen. See [Setting Screen Lock Using PIN on page 135](#) for more information.
  - **Password** - Enter a password to unlock screen. See [Setting Screen Unlock Using Password on page 135](#) for more information.

Lock the screen to protect access to data on the device. Some email accounts require locking the screen. The Locking feature functions differently in Single-user versus Multiple-user mode.


When locked, a slide, pattern, PIN or password is required to unlock the device. Press the Power button to lock the screen. The device also locks after a pre-defined time-out.

Press and release the Power button to wake the device. The Lock screen displays.

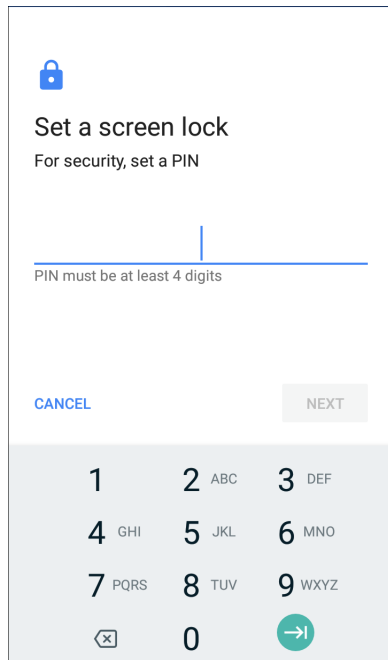
Slide the screen up to unlock. If the Pattern screen unlock feature is enabled, the Pattern screen appears instead of the Lock screen.

If the PIN or Password screen unlock feature is enabled, enter the PIN or password after unlocking the screen.

## Setting Screen Lock Using PIN


1. Swipe down from the Status bar to open the Quick Access panel and then touch .
2. Touch **Security & location**.
3. Touch **Screen lock**.
4. Touch **PIN**.
5. To require a PIN upon device start up select **Yes**, or select **No** not to require a PIN.

**Figure 1** PIN Screen



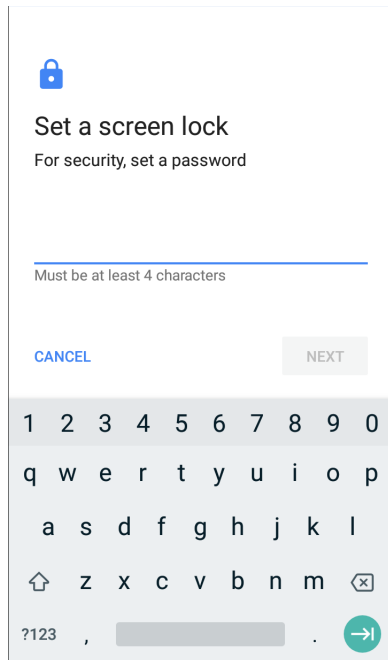
6. Touch in the text field.
7. Enter a PIN (4 numbers) then touch **Next**.
8. Re-enter PIN and then touch **Next**.
9. Select the type of notifications that appear when the screen is locked and then touch **Done**.
10. Touch . The next time the device goes into suspend mode a PIN is required upon waking.

## Setting Screen Unlock Using Password

1. Swipe down from the Status bar to open the Quick Access panel and then touch .
2. Touch **Security & location**.
3. Touch **Screen lock**.
4. Touch **Password**.
5. To require a password upon device start up select **Yes**, or select **No** not to require a password.


6. Touch in the text field.
7. Enter a password (between 4 and 16 characters) then touch **Next**.

**Figure 2** Password Screen

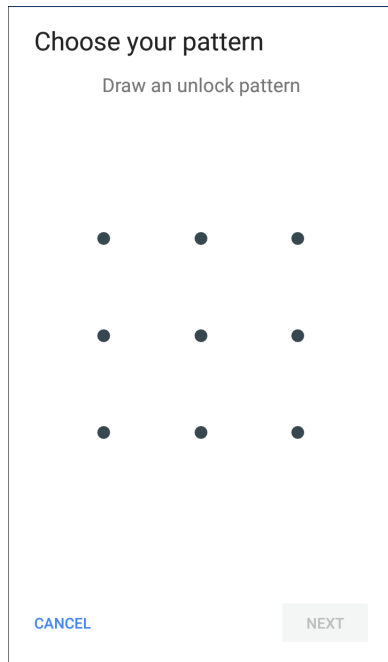


8. Re-enter the password and then touch **Next**.
9. Select the type of notifications that appear when the screen is locked and then touch **Done**.
10. Touch . The next time the device goes into suspend mode a password is required upon waking.

## Setting Screen Unlock Using Pattern

1. Swipe down from the Status bar to open the Quick Access panel and then touch .
2. Touch **Security & location**.
3. Touch **Screen lock**.
4. Touch **Pattern**.
5. To require a pattern upon device start up select **Yes**, or select **No** not to require a pattern.




**Figure 3** Choose Your Pattern Screen

6. Draw a pattern connecting at least four dots.
7. Touch **Continue**.
8. Re-draw the pattern.
9. Touch **Confirm**.
10. Select the type of notifications that appear when the screen is locked and then touch **Done**.
11. Touch . The next time the device goes into suspend mode a pattern is required upon waking.

## Showing Passwords


To set the device to briefly show password characters as the user types:


1. Swipe down from the Status bar to open the Quick Access panel and then touch .
2. Touch **Security & location**.
3. Slide the **Show passwords** switch to the ON position.

## Language Usage



Use the **Language & input** settings to change the device's language, including words added to the dictionary.

### Changing the Language Setting

1. Swipe down from the Status bar to open the Quick Access panel and then touch .
2. Touch **System > Languages & input**.

3. Touch **Languages**. A list of available languages displays.
4. If the desired language is not listed, touch **Add a language** and select a language from the list.
5. Touch and hold  to the right of the desired language, then drag it to the top of the list.
6. The operating system text changes to the selected language.

## Adding Words to the Dictionary

1. Swipe down from the Status bar to open the Quick Access panel and then touch .
2. Touch **System > Languages & input > Advanced > Personal dictionary**.
3. If prompted, select the language where this word or phrase is stored.
4. Touch **+** to add a new word or phrase to the dictionary.
5. Enter the word or phrase.
6. In the **Shortcut** text box, enter a shortcut for the word or phrase.
7. Touch .

## Keyboard Settings

Use the **Languages & input** settings to configure the on-screen keyboards. The device contains the following keyboard settings:


- Enterprise Keyboard
- Gboard - GMS devices only.

## Button Remapping

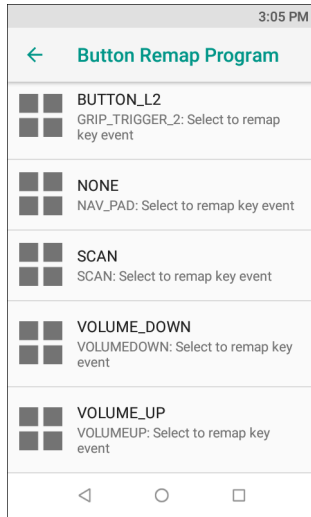
The TC8300's buttons can be programmed to perform different functions or shortcuts to installed applications.


- BUTTON\_L2 - Scan button
- NONE - NAV\_PAD
- SCAN - PTT button.
- VOLUME\_DOWN - Volume down button
- VOLUME\_UP -Volume up button

## Remapping a Button

1. Swipe up from the bottom of the Home screen and touch  >  **Key Programmer**.

**Figure 4** Key Programmer Screen



2. Select the button to remap.
3. Touch the **BUTTON REMAPPING** tab or the **SHORTCUT** tab that lists the available functions and applications.
4. Touch a function or application shortcut to map to the button.  
If you select an application shortcut, the application icon appears next to the button on the **Key Programmer** screen.
5. Touch .

## PTT Express Configuration

The system administrator can manually configure PTT Express by creating an xml file and loading it onto the TC8300. Refer to the *PTT Express User Guide* at <http://www.zebra.com/support> for information on configuring the PTT Express Client application.

### Importing a PTT Express Configuration File

1. Copy the configuration file *ptt\_settings.xml* from a host computer to the root of the On Device Storage. See [USB Communication](#).
2. On the TC8300, use File Browser to move the *ptt\_settings.xml* file from the root of the On Device Storage to the folder: */enterprise/device/settings/ptt*.

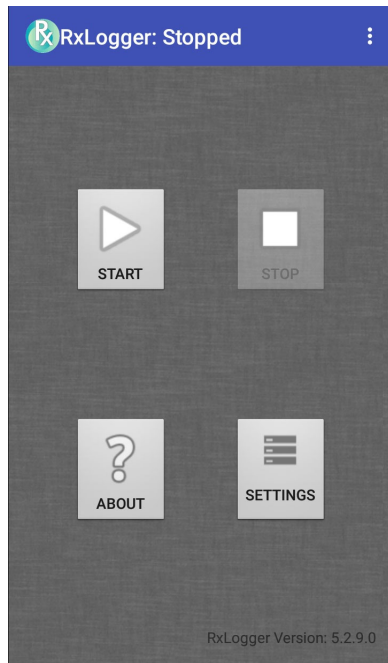
## RxLogger

- ✓ **NOTE:** The configuration file can also be loaded on the TC8300 using ADB. See [Installing Applications Using the Android Debug Bridge on page 157](#)

RxLogger is a comprehensive diagnostic tool that provides application and system metrics, allows for the creation of custom plug-ins, and diagnoses device and application issues. RxLogger logs the following information: CPU load, memory load, memory snapshots, battery consumption, power states, wireless logging,

cellular logging, TCP dumps, Bluetooth logging, GPS logging, logcat, FTP push/pull, ANR dumps, etc. All generated logs and files are saved onto flash storage on the device (internal or external).

**Figure 5** RxLogger



## RxLogger Settings

The RxLogger Settings module provides additional RxLogger settings.

- **Enable notifications** - Select to allow RxLogger notifications in the Status bar and Notification panel.
- **Enable debug logs** - Select to enable debug logs.

## RxLogger Configuration

RxLogger is built with an extensible plug-in architecture and comes packaged with a number of plug-ins already built-in. The included plug-ins are described below.

To open the configuration screen, from the RxLogger home screen touch **Settings**.

**Figure 6** RxLogger Configuration Screen

SAVE	CANCEL
RxLogger Settings	
ANRModule	
KernelModule	
LogcatModule	
LTSMModule	
RamoopsModule	
ResourceModule	
SnapshotModule	
TCPDumpModule	
TombstoneModule	

## ANR Module

Application Not Responsive (ANR) indicates that a running application's UI thread is not responding for a specified time period. RxLogger is able to detect this condition and trigger a copy of the call stack trace of the unresponsive application into the log directory. The event is also indicated in the high level CSV log.

- **Enable Module** - Enables logging for this module.
- **Log path** - Specifies the default log path to store the ANR log files.
- **Collect Historic ANRs** - Collects ANR trace files from the system.

## Kernal Module

The Kernel Module captures kmsg from the system.

- **Enable Module** - Enables logging for this kernal module.
- **Log path** - Specifies the high level log path for storage of all kernal logs. This setting applies globally to all kernal buffers.
- **Kernal Log filename** - Specifies the base log filename for this kernal buffer. The current file count is appended to this name.
- **Max Kernal log file size** - Specifies the maximum size, in megabytes, of an individual log file.
- **Kernal Log interval** - Sets the interval, in seconds, on which to flush the log buffer to the file.
- **Kernal Log file count** - Specifies the number of log files to keep and rotate through. Each log file is subject to the max log size option.
- **Enable System Timestamp in Kernal Log** - Enables system timestamps in kernal logs.
- **System Timestamp Interval** - Sets the interval, in seconds, between system timestamps.

- **Enable Logcat Integration override** - Enables logcat integration overrides.

## Logcat Module

Logcat is an essential debugging tool on Android devices. RxLogger provides the ability to record data from all four of the available logcat buffers. The Logcat plug-in can collect data from multiple logcat buffers provided by the system, which are the main, event, radio, and system buffers. Each of the settings are available for each buffer independently unless otherwise noted.

- **Enable Module** - Enables logging for this module.
- **Log path** - Specifies the high level log path for storage of all logcat logs. This setting applies globally to all logcat buffers.
- **Enable main logcat** - Enables logging for this logcat buffer.
  - **Main Log interval (sec)** - Sets the interval, in seconds, on which to flush the log buffer to the file.
  - **Main Log filename** - Specifies the base log filename for this logcat buffer. The current file count is appended to this name.
  - **Main Log file count** - Specifies the number of log files to keep and rotate through. Each log file is subject to the max log size option.
  - **Main log file size (MB)** - Specifies the maximum size, in megabytes, of an individual log file.
  - **Main log filter** - Custom logcat filter to run on the main buffer.
- **Enable event logcat** - Enables event logging for this logcat buffer.
  - **Event log interval (sec)** - Sets the interval, in seconds, on which to flush the log buffer to the file.
  - **Event log filename** - Specifies the base log filename for this logcat buffer. The current file count is appended to this name.
  - **Event log file count** - Specifies the number of log files to keep and rotate through. Each log file is subject to the max log size option.
  - **Event log file size (MB)** - Specifies the maximum size, in kilobytes, of an individual log file.
  - **Event log filter** - Custom logcat filter to run on the event buffer.
- **Enable radio logcat** - Enables logging for this logcat buffer.
  - **Radio log interval (sec)** - Sets the interval, in seconds, on which to flush the log buffer to the file.
  - **Radio log filename** - Specifies the base log filename for this logcat buffer. The current file count is appended to this name.
  - **Radio log file count** - Specifies the number of log files to keep and rotate through. Each log file is subject to the max log size option.
  - **Radio log file size (MB)** - Specifies the maximum size, in kilobytes, of an individual log file.
  - **Radio log filter** - Custom logcat filter to run on the radio buffer.
- **Enable system logcat** - Enables logging for this logcat buffer.
  - **System log interval (sec)** - Sets the interval, in seconds, on which to flush the log buffer to the file.
  - **System log filename** - Specifies the base log filename for this logcat buffer. The current file count is appended to this name.
  - **System log file count** - Specifies the number of log files to keep and rotate through. Each log file is subject to the max log size option.
  - **System log file size (MB)** - Specifies the maximum size, in kilobytes, of an individual log file.
  - **System log filter** - Custom logcat filter to run on the system buffer.

- **Enable crash logcat** - Enables logging for this crash logcat buffer.
  - **Crash log interval (sec)** - Sets the interval, in seconds, on which to flush the log buffer to the file.
  - **Crash log filename** - Specifies the base log filename for this logcat buffer. The current file count is appended to this name.
  - **Crash log file count** - Specifies the number of log files to keep and rotate through. Each log file is subject to the max log size option.
  - **Crash log file size (MB)** - Specifies the maximum size, in megabytes, of an individual log file.
  - **Crash log filter** - Custom logcat filter to run on the crash buffer.
- **Enable combined logcat** - Enables logging for this logcat buffer.
  - **Enable main buffer** - Enable or disable the addition of the main buffer into the combined logcat file.
  - **Enable event buffer** - Enable or disable the addition of the event buffer into the combined logcat file.
  - **Enable radio buffer** - Enable or disable the addition of the radio buffer into the combined logcat file.
  - **Enable system buffer** - Enable or disable the addition of the system buffer into the combined logcat file.
  - **Enable crash buffer** - Enable or disable the addition of the crash buffer into the combined logcat file.
  - **Combine log interval (sec)** - Sets the interval, in seconds, on which to flush the log buffer to the file.
  - **Combined log filename** - Specifies the base log filename for this logcat buffer. The current file count is appended to this name.
  - **Combined log file count** - Specifies the number of log files to keep and rotate through. Each log file is subject to the max log size option.
  - **Combined log file size (MB)** - Specifies the maximum size, in megabytes, of an individual log file.
  - **Combined log filter** - Custom logcat filter to run on the combined buffer.

## LTS Module

The LTS (Long Term Storage) Module captures data over a long duration of time without losing any data. Whenever a file is done being written, LTS saves it as a GZ file in an organized path for later use.

- **Enable Module** - Enables logging for this module.
- **Storage Directory** - Specifies the high level log path for storage of all logcat logs. This setting applies globally to all logcat buffers.

## Ramoops Module

The Ramoops Module captures the last kmsg from the device.

- **Enable Module** - Enables logging for this module.
- **Log path** - Specifies the high level log path for storage of all ramoops logs. This setting applies globally to all Ramoops buffers.
- **Base filename** - Specifies the base log filename for this kernel buffer. The current file count is appended to this name.
- **Ramoops file count** - Specifies the number of log files to keep and rotate through. Each log file is subject to the log size option.

## Qxdm Module

The Ramoops Module captures Qualcomm Modem Logs from the device.

- **Enable Module** - Enables logging for this module.
- **Log path** - Specifies the storage path for Qxdm files.
- **Qxdm Log Size** - Specifies the maximum size, in kilobytes, of an individual log file.
- **Qxdm test sets to keep** - Specifies the number of test sets to keep. One test set is a start and stop.
- **Choose Log Filter** - Select which filter Qxdm uses to process logs.
- **Path for User Defined Filter** - Specifies the path to a user-defined configuration file.

## Resource Module

The Resource Module captures device information and system statistics at specified intervals. The data is used to determine the health of the device over a period of time.

- **Enable Module** - Enables logging for this module.
- **Log Path** - Specifies the high level log path for storage of all resource logs. This setting applies globally to all resource buffers.
- **Resource Log interval** - Sets the interval, in seconds, on which to flush the log buffer to the file.
- **Resource Log file size** - Specifies the maximum size, in megabytes, of an individual log file.
- **Resource Log file count** - Specifies the number of log files to keep and rotate through. Each log file is subject to the max log size option.
- **Power** - Enables or disables the collection of Battery statistics.
- **System Resource** - Enables or disables the collection of System Resource information.
- **Network** - Enables or disables the collection of Network status.
- **Bluetooth** - Enables or disables the collection of Bluetooth information.
- **Light** - Enables or disables the collection of ambient light level.
- **Heater** - Not supported.

## Snapshot Module

The Snapshot Module collects detailed device statistics at an interval to see detailed device information.

- **Enable Module** - Enables logging for this module.
- **Log Path** - Specifies the base path to use to store the snapshot files
- **Log filename** - Specifies the base filename for all the snapshot files. The current file count is appended to this name.
- **Log Interval (sec)** - Specifies the interval, in seconds, on which to invoke a detailed snapshot.
- **Snapshot file count** - The maximum number of Snapshot files to keep at any one time.
- **Top** - Enables or disables the running of the **top** command for data collection.
- **CPU Info** - Enables detailed per process CPU logging in the snapshot.
- **Memory Info** - Enables logging of detailed per process memory usage in the snapshot.
- **Battery Info** - Enables logging of detailed power information including battery life, on time, charging, and wake locks.
- **Wake Locks** - Enables or disables the collection of the sys/fs wake\_lock information.
- **Time in State** - Enables or disables the collection of the sys/fs cpufreq for each core.
- **Processes** - Enables dumping the complete process list in the snapshot.
- **Threads** - Enables dumping all processes and their threads in the snapshot.



- **Properties** - Enables dumping of all system properties on the device. This includes build/version information as well as state information.
- **Interfaces** - Enables or disables the running of the `netcfg` command for data collection.
- **IP Routing Table** - Enables or disables the collection of the net route for data collection.
- **Connectivity** - Enables or disables the running of the `dumpsys connectivity` command for data collection.
- **Wifi** - Enables or disables the running of the `dumpsys wifi` command for data collection.
- **File systems** - Enables dumping of the available volumes on the file system and the free storage space for each.
- **Usage stats** - Enables dumping of detailed usage information for each package on the device. This includes the number of starts and duration of each run.

### TCPDump Module

The TCPDump Module captures TCP data that happens over the device's networks.

- **Enable Module** - Enables logging for this module.
- **Log path** - Specifies the location to store the TCPDump output log files.
- **Base filename** - Specifies the base filename to use when storing the TCPDump files. The index number of the current log file is appended to the filename.
- **Tcpdump file size (MB)** - Specifies the maximum file size, in megabytes, for each log file created.
- **Tcpdump file count** - Specifies the number of log files to cycle through when storing the network traces.

### Tombstone Module

The Tombstone Module collects tombstone (Linux Native Crashes) logs from the device.



- **Enable Module** - Enables logging for this module.
- **Log path** - Specifies the location to store the Tombstone output log files.
- **Collect Historic tombstones** - Collects new and existing tombstone files.

### Configuration File

RxLogger configuration can be set using an XML file. The `config.xml` configuration file is located in the `RxLogger\config` folder. Copy the file from the device to a host computer using a USB connection. Edit the configuration file and then replace the XML file on the device. There is no need to stop and restart the RxLogger service since the file change is automatically detected.


### Enabling Logging

To enable logging:

1. Swipe the screen up and select .
2. Touch **Start**.
3. Touch .

### Disabling Logging

To disable logging:

1. Swipe the screen up and select .
2. Touch **Stop**.
3. Touch

### Extracting Log Files

1. Connect the device to a host computer using an USB connection.
2. Using a file explorer, navigate to the **RxLogger** folder.
3. Copy the file from the device to the host computer.
4. Disconnect the device from the host computer.

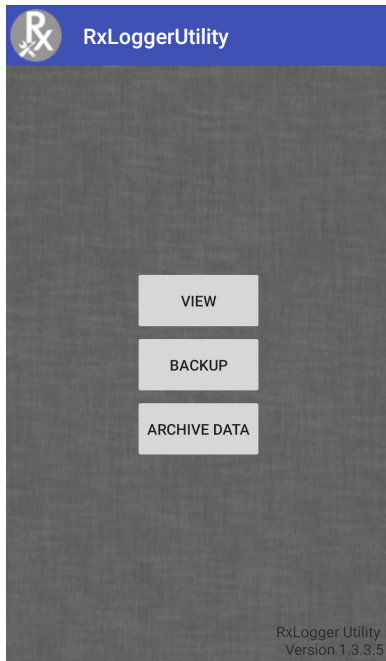
## RxLogger Utility

RxLogger Utility is a data monitoring application for viewing logs in the device while RxLogger is running. Logs and RxLogger Utility features are accessed in the App View or the Overlay View.

### App View

In App View, the user views logs in the RxLogger Utility.

**Figure 7** App View

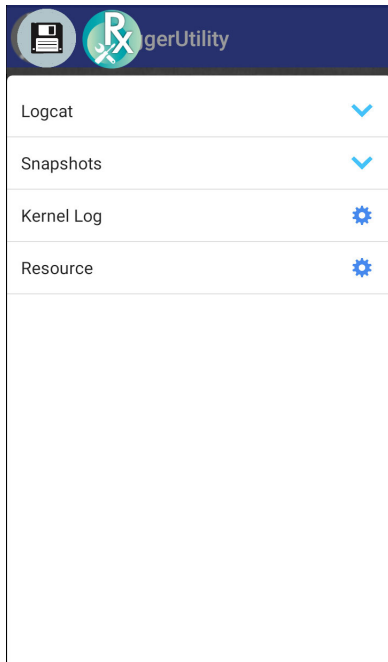


### Viewing Logs

To view logs:

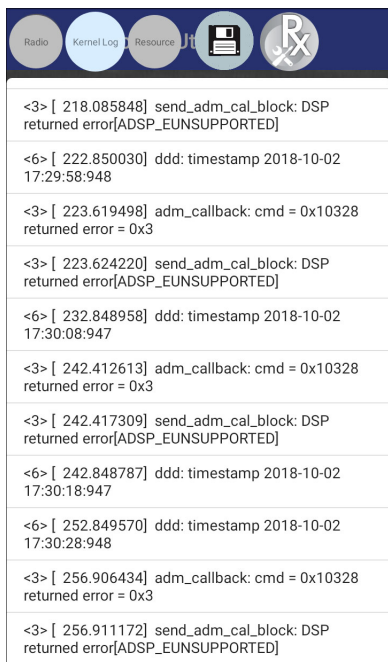
1. Touch the Main Chat Head icon. The Overlay View screen appears.

**Figure 8** Overlay View Screen



2. Touch a log to open it. The user can open many logs with each displaying a new sub Chat Head.
3. If necessary, scroll left or right to view additional Sub Chat Head icons.
4. Touch a Sub Chat Head to display the log contents.

**Figure 9** Log File

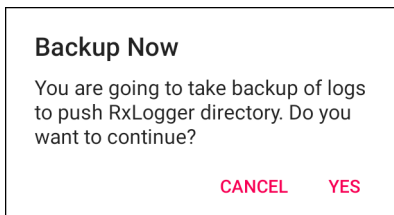


## Backup

RxLogger Utility allows the user to make a zip file of the **RxLogger** folder in the device, which by default contains all the RxLogger logs stored in the device.

To save the backup data, touch **BACKUP > Yes**.

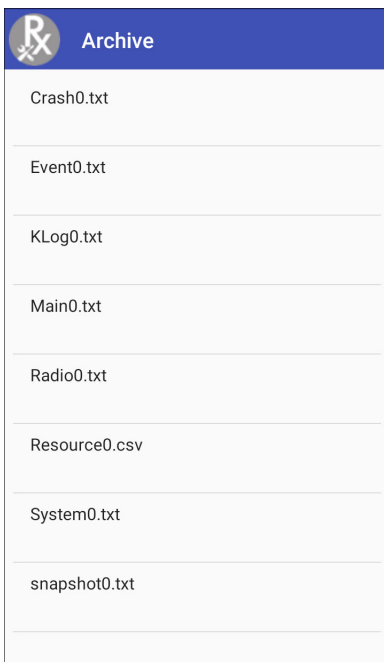
**Figure 10** Backup Message



## Archive Data

View all the RxLogger logs stored in the default **RxLogger** directory. Logs viewed in the Archive window are not live.

**Figure 11** Archive



To view the log files, touch **ARCHIVE DATA** and then touch a log file.

## Overlay View

Use Overlay View to display RxLogger information while using other apps or on the home screen. Overlay View is accessed using the Main Chat Head.

## Initiating the Main Chat Head

To initiate the Main Chat Head:

1. Open **RxLogger**.
2. Touch **☰** > **Toggle Chat Head**. The Main Chat Head icon appears on the screen.
3. Touch and drag the Main Chat head icon to move it around the screen.

## Removing the Main Chat Head

To remove the Main Chat Head icon:

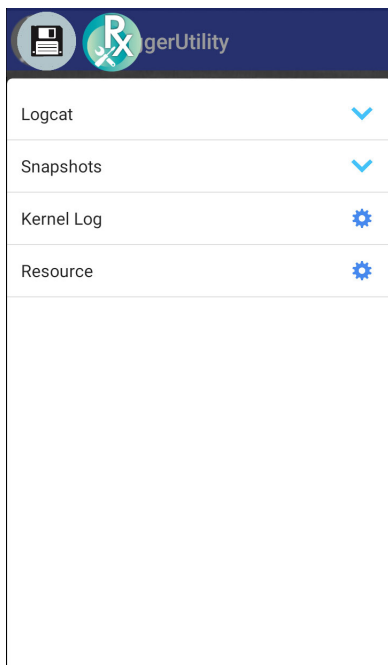
1. Touch and drag the icon. A circle with an X appears.
2. Move the icon over the circle and then release.

## Viewing Logs

To view logs:

1. Touch the Main Chat Head icon. The Overlay View screen appears.

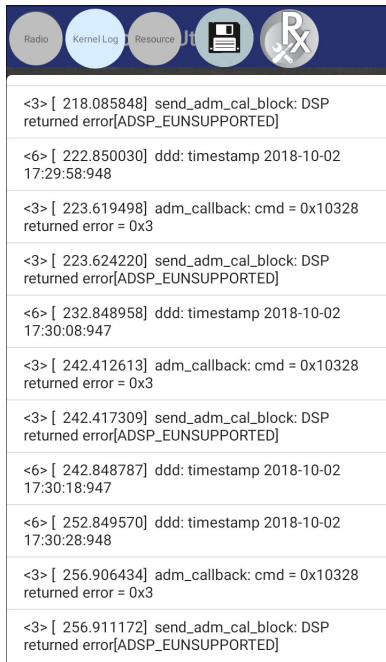
**Figure 12** Overlay View Screen



2. Touch a log to open it. The user can open many logs with each displaying a new sub Chat Head.
3. If necessary, scroll left or right to view additional Sub Chat Head icons.

4. Touch a Sub Chat Head to display the log contents.

**Figure 13** Log File




## Removing a Sub Chat Head Icon

To remove a sub chat Head icon, press and hold the icon until it disappears.


## Backing Up In Overlay View

RxLogger Utility allows the user to make a zip file of the **RxLogger** folder in the device, which by default contains all the RxLogger logs stored in the device.

The Backup icon is always available in Overlay View.

1. Touch . The Backup dialog box appears.
2. Touch **Yes** to create the back up.

## About Phone

Use About phone settings to view information about the device. Swipe down from the Status bar to open the Quick Access panel and then touch  > **System** > **About phone**.

- **Status** - Touch to display the following:
  - **Battery status** - Indicates if the battery is charging (on AC power) or discharging (on battery power).
  - **Battery level** - Indicates the battery charge level.
  - **IP address** - Displays the IP address of the device.
  - **Wi-Fi MAC address** - Displays the Wi-Fi radio MAC address.
  - **Ethernet MAC address** - Displays the Ethernet driver MAC address.
  - **Bluetooth address** - Displays the Bluetooth radio Bluetooth address.
  - **Serial number** - Displays the serial number of the device.
  - **MSM serial number** - Displays the serial number of the MSM.
  - **Up time** - Displays the time that the device has been running since being turned on.
- **Battery Information** - Displays information about the battery.
- **SW components** - Lists filenames and versions for various software on the device.
- **Legal information** - Opens a screen to view legal information about the software included on the device.
- **Model** - Displays the devices model number.
- **Android version** - Displays the operating system version.
- **Android security patch level** - Displays the security patch level date.
- **Kernel version** - Displays the kernel version.
- **Build Fingerprint** - Defines Device Manufacturer, Model, Android version and Build version together in one location.
- **Build number** - Displays the software build number.



# Application Deployment

## Introduction

This chapter describes features in Android including new security features, how to package applications, and procedures for deploying applications onto the device.

## Security

The device implements a set of security policies that determine whether an application is allowed to run and, if allowed, with what level of trust. To develop an application, you must know the security configuration of the device, and how to sign an application with the appropriate certificate to allow the application to run (and to run with the needed level of trust).



**NOTE:** Ensure the date is set correctly before installing certificates or when accessing secure web sites.

## Secure Certificates


If the VPN or Wi-Fi networks rely on secure certificates, obtain the certificates and store them in the device's secure credential storage, before configuring access to the VPN or Wi-Fi networks.

If downloading the certificates from a web site, set a password for the credential storage. The device supports X.509 certificates saved in PKCS#12 key store files with a .p12 extension (if key store has a .pfx or other extension, change to .p12).

The device also installs any accompanying private key or certificate authority certificates contained in the key store.

## Installing a Secure Certificate

To install a secure certificate:

1. Copy the certificate from the host computer to the root of the device's internal memory. See [USB Communication](#) for information about connecting the device to a host computer and copying files.
2. Swipe down from the Status bar to open the Quick Access panel and then touch .
3. Touch **Security & location > Advanced > Encryption & credentials**.
4. Touch **Install from storage**.
5. Navigate to the location of the certificate file.

6. Touch the filename of the certificate to install.
7. If prompted, enter the password for credential storage. If a password has not been set for the credential storage, enter a password for it twice and then touch **OK**.
8. If prompted, enter the certificate's password and touch **OK**.
9. Enter a name for the certificate and in the Credential use drop-down, select **VPN and apps** or **Wi-Fi**.

**Figure 14** Name the Certificate Dialog Box

**Name the certificate**

Certificate name:

Credential use:  
 VPN and apps ▼

The package contains:  
 one user certificate

CANCEL    OK

10. Touch **OK**.

The certificate can now be used when connecting to a secure network. For security, the certificate is deleted from the internal memory.

## Configuring Credential Storage Settings

1. Swipe down from the Status bar to open the Quick Access panel and then touch .
2. Touch **Security & location > Encryption & credentials**.
  - **Trusted credentials** - Touch to display the trusted system and user credentials.
  - **Install from storage** - Touch to install a secure certificate from the internal storage.
  - **Clear credentials** - Deletes all secure certificates and related credentials.

## Development Tools

### Android

Android development tools are available at [developer.android.com](http://developer.android.com).


To start developing applications for the device, download the development SDK and the Android Studio IDE. Development can take place on a Microsoft® Windows®, Mac® OS X®, or Linux® operating system.

Applications are written in the Java language, but compiled and executed in the Dalvik VM (a non-Java virtual machine). Once the Java code is compiled cleanly, the developer tools make sure the application is packaged properly, including the AndroidManifest.xml file.

The development SDK is distributed as a ZIP file that unpacks to a directory on the host computer hard drive. The SDK includes:

- android.jar
  - Java archive file containing all of the development SDK classes necessary to build an application.
- documentation.html and docs directory
  - The SDK documentation is provided locally and on the Web. It's largely in the form of JavaDocs, making it easy to navigate the many packages in the SDK. The documentation also includes a high-level Development Guide and links to the broader community.
- Samples directory
  - The samples subdirectory contains full source code for a variety of applications, including ApiDemo, which exercises many APIs. The sample application is a great place to explore when starting application development.
- Tools directory
  - Contains all of the command-line tools to build applications. The most commonly employed and useful tool is the adb utility.
- usb\_driver
  - Directory containing the necessary drivers to connect the development environment to an enabled device. These files are only required for developers using the Windows platform.

Open the **Developer options** screen to set development related settings.

By default, the Developer Options are hidden. To un-hide the developer options, swipe down from the Status bar to open the Quick Access panel and then touch .

Touch **System > About phone**. Scroll down to **Build number**. Tap **Build number** seven times until **You are now a developer** appears.

Touch **System > Developer options**. Slide the switch to the **ON** position to enable developer options.

## GMS Restricted

GMS Restricted mode deactivates Google Mobile Services (GMS). All GMS apps are disabled on the device and communication with Google (analytics data collection and location services) is disabled.

Use StageNow to disable or enable GMS Restricted mode. After a device is in GMS Restricted mode, enable and disable individual GMS apps and services using StageNow. To ensure GMS Restricted mode persists after an Enterprise Reset, use the Persist Manager option in StageNow. For more information on StageNow, refer to [techdocs.zebra.com](http://techdocs.zebra.com).

## ADB USB Setup

To use the ADB, install the USB driver. This assumes that the development SDK has been installed on the host computer. Go to [developer.android.com/sdk/index.html](http://developer.android.com/sdk/index.html) for details on setting up the development SDK.

ADB driver for Windows and Linux are available on the Zebra Support Central web site at [www.zebra.com/support](http://www.zebra.com/support). Download the ADB and USB Driver Setup package. Following the instructions with the package to install the ADB and USB drivers for Windows and Linux.

## Application Installation

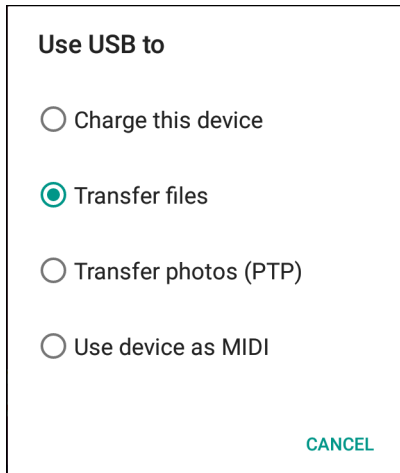
After an application is developed, install the application onto the device using one of the following methods:


- Android Debug Bridge, see [Installing Applications Using the Android Debug Bridge on page 157](#).
- Mobile device management (MDM) platforms that have application provisioning. Refer to the MDM software documentation for details.

## Installing Applications Using the USB Connection

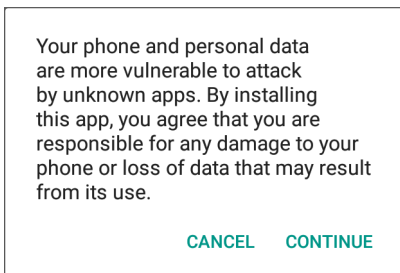
1. Connect the device to a host computer using the Rugged Charge/USB cable.
2. Pull down the Notification panel and touch **USB for Charging**.

**Figure 15** Use USB Dialog Box

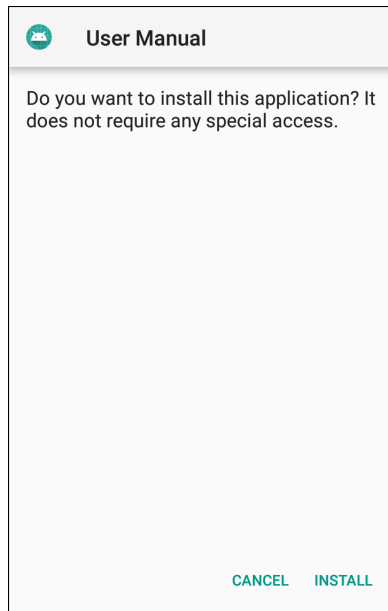


3. Touch **Transfer files**.
4. On the host computer, open a **Files** application.
5. On the host computer, copy the application .apk file from the host computer to the device.
6. Disconnect the device from the host computer.
7. Swipe the screen up and select  to view files on the Internal Storage.
8. Locate the application .apk file.
9. Touch the application file.

**Figure 16** Install App Permission Dialog Box



10. Touch **Continue** to install the app or **Cancel** to stop the installation.

**Figure 17** Accept Installation Screen

11. To confirm installation and accept what the application affects, touch **Install** otherwise touch **Cancel**.
12. Touch **Open** to open the application or **Done** to exit the installation process. The application appears in the App list.

## Installing Applications Using the Android Debug Bridge

Use ADB commands to install application onto the device.



Ensure that the ADB drivers are installed on the host computer. See [ADB USB Setup on page 155](#).

1. Connect the device to a host computer using USB. See [USB Communication](#).
2. By default, the Developer Options are hidden. To un-hide the developer options, swipe down from the Status bar to open the Quick Access panel and then touch **⚙**.
3. Touch **System > About phone**. Scroll down to **Build number**. Tap **Build number** seven times until **You are now a developer appears**.
4. Touch **System > Developer options**.
5. Slide the switch to the **ON** position.
6. Touch **USB Debugging**. A check appears in the check box. The **Allow USB debugging?** dialog box appears.
7. Touch **OK**.
8. On the host computer, open a command prompt window and use the adb command:  
`adb install <application>`  
 where: <application> = the path and filename of the apk file.
9. Disconnect the device from the host computer. See [USB Communication](#).

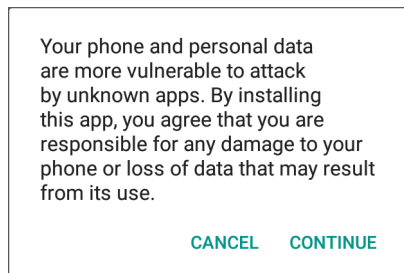
## Installing Applications Using a microSD Card



**CAUTION:** When connecting the device to a host computer and mounting its microSD card, follow the host computer's instructions for connecting and disconnecting USB devices, to avoid damaging or corrupting files.

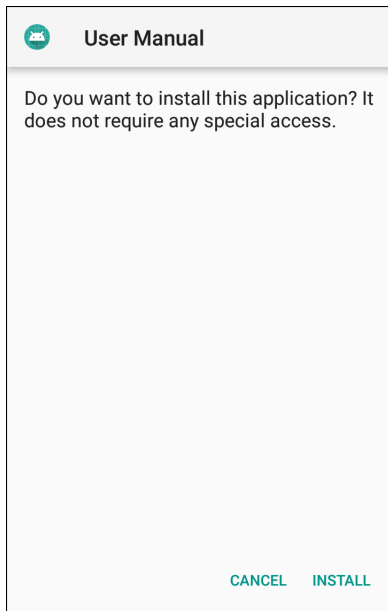
1. Connect the device to a host computer using USB. See [USB Communication](#).
2. Copy the application APK file from the host computer to the microSD card.
3. Remove the microSD card from the host computer.
4. Press and hold the Power button until the menu appears.
5. Touch **Power off**.
6. Touch **OK**.
7. Install the microSD card. See [Installing Applications Using a microSD Card on page 158](#).
8. Press and hold the Power button to turn on the device.
9. Swipe the screen up and select  to view files on the microSD card.
10. Touch  > **SD card**.
11. Locate the application .apk file.
12. Touch the application file.

**Figure 18** Install App Permission Dialog Box



13. Touch **Continue** to install the app or **Cancel** to stop the installation.

**Figure 19** Accept Installation Screen



14. To confirm installation and accept what the application affects, touch **Install** otherwise touch **Cancel**.

15. Touch **Open** to open the application or **Done** to exit the installation process. The application appears in the App list.

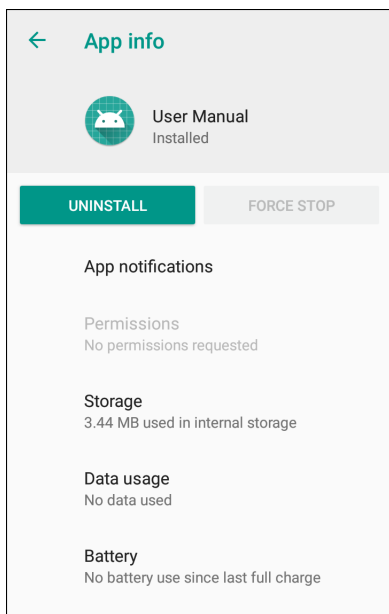
## Uninstalling an Application

To uninstall an application:

1. Swipe down from the Status bar to open the Quick Access panel and then touch **⚙**.
2. Touch **Apps & notifications**.
3. Touch **See all apps** to view all apps in the list.
4. Scroll through the list to the app.

5. Touch the app. The **App info** screen appears.

**Figure 20** App Info Screen



6. Touch **Uninstall**.

7. Touch **OK** to confirm.

## System Update

When upgrading, downgrading or performing a system update, use the appropriate files as shown in the following table.

**Table 1** Upgrade/Downgrade

OS	Full Package Update	Factory Reset	Enterprise Reset
Upgrade KitKat® to Lollipop AOSP *	T8KN0LXXVRGEF02206.zip	T8KN0LXXVRFXX02206.zip	T8KN0LXXVREXX02206.zip
Upgrade KitKat to Lollipop GMS *	T8KN0LXXARGEF02206.zip	T8KN0LXXARFXX02206.zip	T8KN0LXXAREXX02206.zip
Update Lollipop AOSP to Lollipop GMS *	T8KN0LXXARGEF02206.zip	T8KN0LXXARFXX02206.zip	T8KN0LXXAREXX02206.zip
Update Lollipop GMS to Lollipop AOSP *	T8KN0LXXVRGEF02206.zip	T8KN0LXXVRFXX02206.zip	T8KN0LXXVREXX02206.zip
Downgrade Lollipop AOSP to KitKat	T8KN0KEXVRDEF10071.zip	N/A	X
Downgrade Lollipop GMS to KitKat	T8KN0KEXVRDEF10071.zip	N/A	X



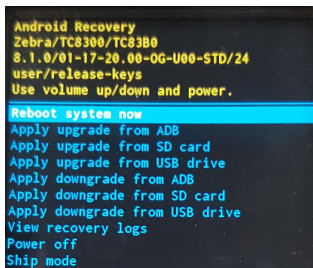


**NOTE:** For detailed instructions, see the TC8300 Release Notes on the Support & Downloads web site.

System Update packages can contain either partial or complete updates for the operating system. We distribute the System Update packages on the Zebra Support & Downloads web site.

1. Download the system update package:
  - a. Go to the Zebra Support & Downloads web site, <http://www.zebra.com/support>.
  - b. Download the appropriate System Update package to a host computer.
2. Copy the System Update Package zip file to the root directory of the microSD card. See [USB Communication on page 75](#).
3. Press and hold the Power button until the menu appears.
4. Touch **Power off**.  
The device turns off.
5. Press and release the Power button. Then press and hold the Power button and the Scan trigger.
6. When the Zebra splash screen appears, release the button and trigger.  
The System Recovery screen appears.

**Figure 21** System Recovery Screen



7. Press the Up and Down volume buttons to navigate to the **apply update from SD card** option.
8. Press the Power button.
9. Press the Up and Down volume buttons to navigate to the System Update Package zip file.
10. Press the Power button.  
The System Update installs and then the TC8300 resets.


## Storage

The device contains four types of file storage:

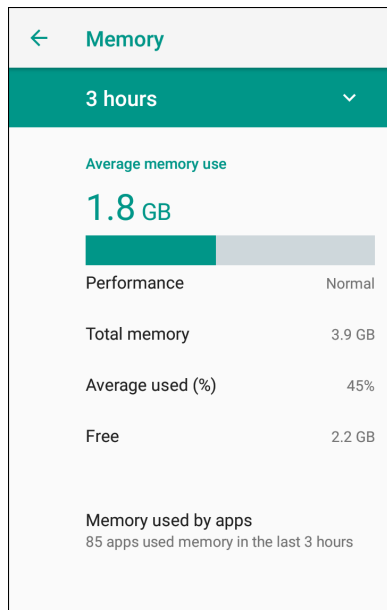
- Random Access Memory (RAM)
- External Storage
- Internal Storage
- Enterprise folder.

## Random Access Memory

Executing programs use RAM to store data. Data stored in RAM is lost upon a reset. The operating system manages how applications use RAM. It only allows applications and component processes and services to use RAM when required. It may cache recently used processes in RAM, so they restart more quickly when opened again, but it will erase the cache if it needs the RAM for new activities.

1. To view the amount of free and used memory, swipe down from the Status bar to open the Quick Access panel and then touch .
2. Touch **System > Developer options > Memory**.

**Figure 22** Memory Screen




The screen displays the amount of used and free RAM.

- **Performance** - Indicates memory performance.
- **Total memory** - Indicates the total amount of RAM available.
- **Average used (%)** - Indicates the average amount of memory (as a percentage) used during the period of time selected (default - 3 hours).
- **Free** - Indicates the total amount of unused RAM.
- **Memory used by apps** - Touch to view RAM usage by individual apps.

## External Storage

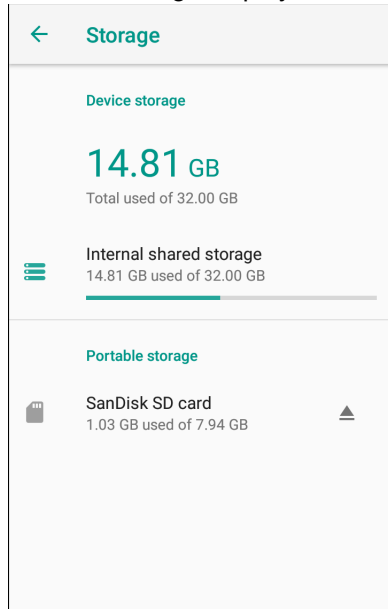
The device can have a removable microSD card. The microSD card content can be viewed and files copied to and from when the device is connected to a host computer.

To view the used and available space on the microSD card:

1. Swipe down from the Status bar to open the Quick Access panel and then touch .
2. Touch **Storage**.

**Figure 23** External Storage Screen

Portable storage displays the total amount of space on the installed and the amount used.



To unmount the , touch ▲.

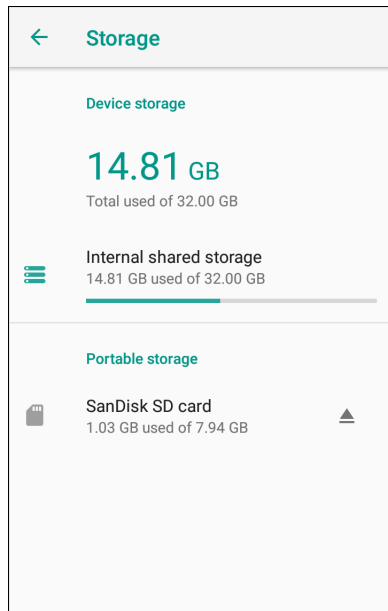
Touch to view the contents of the card.

## Internal Storage

The device has internal storage. The internal storage content can be viewed and files copied to and from when the device is connected to a host computer. Some applications are designed to be stored on the internal storage rather than in internal memory.

To view the used and available space on the internal storage:

1. Swipe down from the Status bar to open the Quick Access panel and then touch ⚙️.
2. Touch **Storage**.


**Figure 24** Storage Screen

## Enterprise Folder

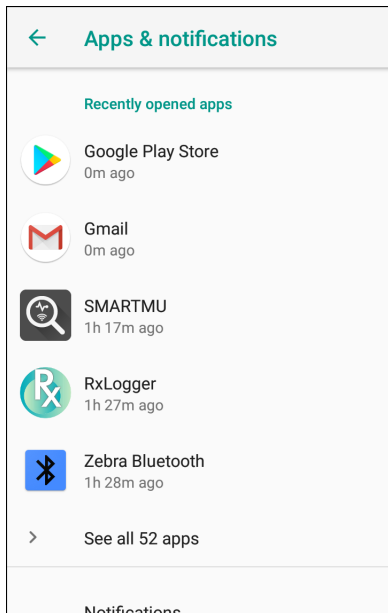
The Enterprise folder (within internal flash) is a super-persistent storage that is persistent after a reset and an Enterprise Reset. The Enterprise folder is erased during a Factory Reset. The Enterprise folder is used for deployment and device-unique data. The Enterprise folder is approximately 232 MB (formatted). Applications can persist data after an Enterprise Reset by saving data to the enterprise/user folder. The folder is ext4 formatted and is only accessible from a host computer using ADB or from an MDM.

## App Management

Apps use two kinds of memory: storage memory and RAM. Apps use storage memory for themselves and any files, settings, and other data they use. They also use RAM when they are running.

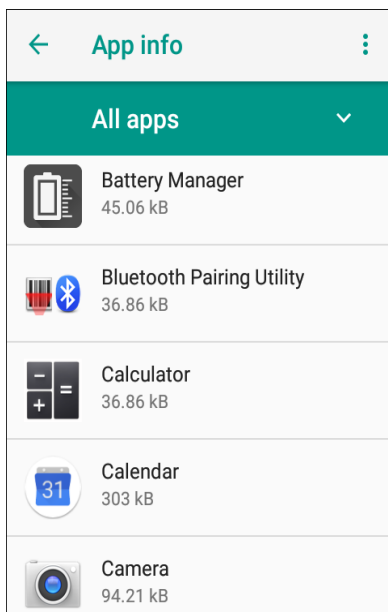
1. Swipe down from the Status bar to open the Quick Access panel and then touch .
2. Touch **Apps & notifications**.

**Figure 25** Apps & Notifications Screen



3. Touch **See all XX apps** to view all apps on the device.

**Figure 26** App Info Screen



4. Touch **>** **Show system** to include system processes in the list.
5. Touch an app, process, or service in the list to open a screen with details about it and, depending on the item, to change its settings, permissions, notifications and to force stop or uninstall it.

## Viewing App Details



Apps have different kinds of information and controls, but commonly include:

- **Force stop** - stop an app.

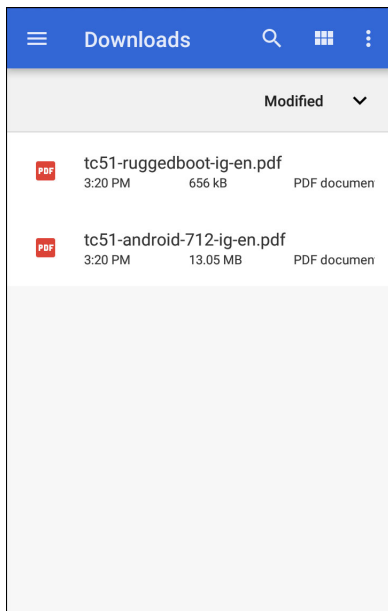
- **Disable** - disable an app.
- **Uninstall** - remove the app and all of its data and settings from the device. See [Uninstalling an Application on page 159](#) for information about uninstalling apps.
- **Storage** - lists how much information is stored, and includes a button for clearing it.
- **Data usage** - provides information about data (Wifi) consumed by an app.
- **Permissions** - lists the areas on the device that the app has access to.
- **Notifications** - set the app notification settings.
- **Open by default** - clears If you have configured an app to launch certain file types by default, you can clear that setting here.
- **Battery** - lists the amount of computing power used by the app.
- **Memory** - lists the average app memory usage.
- Advanced
  - **Draw over other apps** - allows an app to display on top of other apps.


## Managing Downloads

Files and apps downloaded using the Browser or Email are stored on the Internal storage in the Download directory. Use the Downloads app to view, open, or delete downloaded items.

1. Swipe the screen up and touch .
2. Touch  > **Downloads**.

**Figure 27** Files - Downloads Screen



3. Touch and hold an item, select items to delete and touch . The item is deleted from the device.

# Maintenance and Troubleshooting

## Introduction

This chapter includes instructions on cleaning and storing the device, and provides troubleshooting solutions for potential problems during operation.

## Maintaining the Device

For trouble-free service, observe the following tips when using the device:

- In order to avoid scratching the screen, use the supplied stylus or plastic-tipped pens intended for use with a touch-sensitive screen. Never use an actual pen or pencil or other sharp object on the surface of the device screen.
- The touch-sensitive screen of the device is glass. Do not drop the device or subject it to strong impact.
- Protect the device from temperature extremes. Do not leave it on the dashboard of a car on a hot day, and keep it away from heat sources.
- Do not store the device in any location that is dusty, damp, or wet.
- Use a soft lens cloth to clean the device. If the surface of the device screen becomes soiled, clean it with a soft cloth moistened with an approved cleanser. For a list of approved cleansers, see [Approved Cleanser Active Ingredients on page 168](#).
- Periodically replace the rechargeable battery to ensure maximum battery life and product performance. Battery life depends on individual usage patterns.

## Battery Safety Guidelines

- The area in which the units are charged should be clear of debris and combustible materials or chemicals. Particular care should be taken where the device is charged in a non commercial environment.
- Follow battery usage, storage, and charging guidelines found in this guide.
- Improper battery use may result in a fire, explosion, or other hazard.
- To charge the mobile device battery, the battery and charger temperatures must be between +32°F and +104°F (0°C and +40°C)
- Do not use incompatible batteries and chargers, including non-Zebra batteries and chargers. Use of an incompatible battery or charger may present a risk of fire, explosion, leakage, or other hazard. If you have any questions about the compatibility of a battery or a charger, contact the Global Customer Support Center.
- For devices that utilize a USB port as a charging source, the device shall only be connected to products that bear the USB-IF logo or have completed the USB-IF compliance program.
- Do not disassemble or open, crush, bend or deform, puncture, or shred battery.

- Severe impact from dropping any battery-operated device on a hard surface could cause the battery to overheat.
- Do not short circuit a battery or allow metallic or conductive objects to contact the battery terminals.
- Do not modify or remanufacture, attempt to insert foreign objects into the battery, immerse or expose to water or other liquids, or expose to fire, explosion, or other hazard.
- Do not leave or store the equipment in or near areas that might get very hot, such as in a parked vehicle or near a radiator or other heat source. Do not place battery into a microwave oven or dryer.
- Battery usage by children should be supervised.
- Please follow local regulations to properly dispose of used re-chargeable batteries.
- Do not dispose of batteries in fire.
- In the event of a battery leak, do not allow the liquid to come in contact with the skin or eyes. If contact has been made, wash the affected area with water for 15 minutes and seek medical advice.
- If you suspect damage to your equipment or battery, contact Customer Support to arrange for inspection.

## Long Term Storage

When storing the device for a long period of time, it is recommended to remove the battery. When returning the device to everyday operation, install a fully charged battery.

## Cleaning Instructions



**CAUTION:** Always wear eye protection.

Read warning label on alcohol product before using.

If you have to use any other solution for medical reasons please contact the Global Customer Support Center for more information.



**WARNING:** Avoid exposing this product to contact with hot oil or other flammable liquids. If such exposure occurs, unplug the device and clean the product immediately in accordance with these guidelines.

## Approved Cleanser Active Ingredients

100% of the active ingredients in any cleaner must consist of one or some combination of the following: isopropyl alcohol, bleach/sodium hypochlorite<sup>1</sup> (see important note below), or mild dish soap.



- Use pre-moistened wipes and do not allow liquid cleaner to pool.

<sup>1</sup>When using sodium hypochlorite (bleach) based products always follow the manufacturer's recommended instructions: use gloves during application and remove the residue afterwards with a damp alcohol cloth or a cotton swab to avoid prolonged skin contact while handling the device.

Due to the powerful oxidizing nature of sodium hypochlorite the metal surfaces on the device are prone to oxidation (corrosion) when exposed to this chemical in the liquid form (including wipes). In the event that these type of disinfectants come in contact with metal on the device, prompt removal with an alcohol-dampened cloth or cotton swab after the cleaning step is critical.

## Harmful Ingredients

The following chemicals are known to damage the plastics on the device and should not come in contact with the device: acetone; ketones; ethers; aromatic and chlorinated hydrocarbons; aqueous or alcoholic alkaline solutions; ethanolamine; toluene; trichloroethylene; benzene; carbolic acid and TB-lysoform.



Many vinyl gloves contain phthalate additives, which are often not recommended for medical use and are known to be harmful to the housing of the device.

### Device Cleaning Instructions

Do not apply liquid directly to the device. Dampen a soft cloth or use pre-moistened wipes. Do not wrap the device in the cloth or wipe, but gently wipe the unit. Be careful not to let liquid pool around the display window or other places. Allow the unit to air dry before use.



**NOTE:** For thorough cleaning, it is recommended to first remove all accessory attachments, such as hand straps or cradle cups, from the mobile device and to clean them separately.

### Special Cleaning Notes

The device should not be handled while wearing vinyl gloves containing phthalates, or before hands are washed to remove contaminant residue after gloves are removed.

If products containing any of the harmful ingredients listed above are used prior to handling the device, such as hand sanitizer that contain ethanalamine, hands must be completely dry before handling the device to prevent damage to the device.



**IMPORTANT:** If the battery connectors are exposed to cleaning agents, thoroughly wipe off as much of the chemical as possible and clean with an alcohol wipe. It is also recommended to install the battery in the terminal prior to cleaning and disinfecting the device to help minimize buildup on the connectors.

When using cleaning/disinfectant agents on the device, it is important to follow the directions prescribed by the cleaning/disinfectant agent manufacturer.

### Cleaning Materials Required

- Alcohol wipes
- Lens tissue
- Cotton-tipped applicators
- Isopropyl alcohol
- Can of compressed air with a tube.

### Cleaning Frequency

The cleaning frequency is at the customer's discretion due to the varied environments in which the mobile devices are used and may be cleaned as frequently as required. When dirt is visible, it is recommended to clean the mobile device to avoid build up of particles which make the device more difficult to clean later on.

### Cleaning the Device

#### Housing

Thoroughly wipe the housing, including all buttons and triggers, using an approved alcohol wipe.

### Display

The display can be wiped down with an approved alcohol wipe, but care should be taken not to allow any pooling of liquid around the edges of the display. Immediately dry the display with a soft, non-abrasive cloth to prevent streaking.

### Exit Window

Wipe the exit window periodically with a lens tissue or other material suitable for cleaning optical material such as eyeglasses.

## Cleaning Battery Connectors

To clean the battery connectors:

1. Remove the main battery from the mobile computer.
2. Dip the cotton portion of the cotton-tipped applicator in isopropyl alcohol.
3. To remove any grease or dirt, rub the cotton portion of the cotton-tipped applicator back-and-forth across the connectors on the battery and terminal sides. Do not leave any cotton residue on the connectors.
4. Repeat at least three times.
5. Use a dry cotton-tipped applicator and repeat steps 3 and 4. Do not leave any cotton residue on the connectors.
6. Inspect the area for any grease or dirt and repeat the cleaning process if necessary.



**CAUTION:** After cleaning the battery connectors with bleach-based chemicals, follow the Battery Connector Cleaning instructions to remove bleach from the connectors.

## Cleaning Cradle Connectors

To clean the connectors on a cradle:

1. Remove the DC power cable from the cradle.
2. Dip the cotton portion of the cotton-tipped applicator in isopropyl alcohol.
3. Rub the cotton portion of the cotton-tipped applicator along the pins of the connector. Slowly move the applicator back-and-forth from one side of the connector to the other. Do not leave any cotton residue on the connector.
4. All sides of the connector should also be rubbed with the cotton-tipped applicator.
5. Remove any lint left by the cotton-tipped applicator.
6. If grease and other dirt can be found on other areas of the cradle, use a lint-free cloth and alcohol to remove.
7. Allow at least 10 to 30 minutes (depending on ambient temperature and humidity) for the alcohol to air dry before applying power to cradle.

If the temperature is low and humidity is high, longer drying time is required. Warm temperature and low humidity requires less drying time.



**CAUTION:** After cleaning the cradle connectors with bleach-based chemicals, follow the Cleaning Cradle Connectors in-

structions to remove bleach from the connectors.

## Troubleshooting

### TC8300

**Table 2** *Troubleshooting the TC8300*

Problem	Cause	Solution
Device does not turn on.	Battery not charged.	Charge or replace the battery in the device.
	Battery not installed properly.	Ensure battery is installed properly. See <a href="#">Installing the Battery on page 22</a> .
	System crash.	Perform a soft reset. If the device still does not turn on, perform a hard reset. See <a href="#">Resetting the TC8300 on page 25</a> .
Battery did not charge.	Battery failed.	Replace battery. If the device still does not operate, try a soft reset, then a hard reset. See <a href="#">Resetting the TC8300 on page 25</a> .
	Device removed from cradle before charging completed.	Insert the device into the cradle and begin charging. The 6,700 mAh battery charges from 0 - 90% in less than four hours at room temperature. The 7,000 mAh battery charges from 0 - 90% in less than five hours at room temperature.
	Ambient temperature of the cradle is too warm or too cold.	The ambient temperature must be between 0 °C and 40 °C (32 °F and 104 °F).
During data communication, no data was transmitted, or transmitted data was incomplete.	Device unplugged from host computer during communication.	Reconnect the programming cable to the host computer and re-transmit.
	Communication software was incorrectly installed or configured.	See system administrator.
Device turns itself off.	Device is inactive.	The device turns off after a period of inactivity. If the device is running on battery power, this period can be set to 15 seconds, 30 seconds, 1 minute, 2 minutes, 5 minutes, 10 minutes, or 30 minutes. Change the setting if you need a longer delay before the automatic shutoff feature activates.
	Battery is depleted.	Place the device in the cradle to re-charge the battery.
	Battery is not inserted properly.	Insert the battery properly (see <a href="#">Installing the Battery on page 22</a> ).
	The device's battery is low and it powers down to protect memory content.	Place the device in the cradle to re-charge the battery.

**Table 2** *Troubleshooting the TC8300 (Continued)*

Problem	Cause	Solution
A message appears stating that the device memory is full.	Too many files stored on the device.	Delete unused memos and records. You can save these records on the host computer.
	Too many applications installed on the device.	If you have installed additional applications on the device, remove them to recover memory.
The device does not accept scan input.	Unreadable bar code.	Ensure the symbol is not defaced.
	Distance between scanner exit window and bar code is incorrect.	Move the device closer or further from the bar code to the proper scanning range.
	Device is not programmed for the bar code.	Verify that the device can read the type of bar code being scanned (See <a href="#">Specifications</a> ). Ensure that the bar code parameters are set properly for the bar code being scanned.
	Device is not programmed to generate a beep.	Verify that a beep on a good decode is used.
During USB data communications, no data was transmitted, or transmitted data was incomplete.	Incorrect cable connection.	See <a href="#">Accessories</a> .
	Communications software is not installed or configured properly.	See <a href="#">Accessories</a> .

## Cradles

**Table 3** *Troubleshooting the Cradles*

Symptom	Possible Cause	Solution
Device battery is not charging.	Device was removed from cradle or cradle was unplugged from AC power.	Ensure cradle is receiving power. Ensure device is seated correctly. Confirm main battery is charging. The battery fully charges in approximately four hours.
	Battery is faulty.	Verify that other batteries charge properly. If so, replace the faulty battery (see <a href="#">Installing the Battery on page 22</a> ).
	The device is not fully seated in the cradle.	Remove and re-insert the device into the cradle, ensuring it is firmly seated.
	Ambient temperature of the cradle is too warm or too cold.	Move the cradle to an area where the ambient temperature is between 0 °C and 40 °C (32 °F and 104 °F).

# Specifications

## Technical Specifications

The following tables summarize the device's intended operating environment and general technical hardware specifications.

### TC8300

Table 4 Technical Specifications

Item	Description
<b>Physical and Environmental Characteristics</b>	
Dimensions (H x L x W)	233 mm x 76 mm x 64 mm 9.17 in. x 2.99 in. x 2.52 in. DPM: 233 mm x 76 mm x 76mm 9.17 in. x 3.0 in. x 3.0 in.
Weight	Base: 490 g (17.2 oz) Package 1: 500 g (17.6 oz) DPM: 535 g (18.9 oz)
Display	Color Transflective LCD, 4 in. diagonal, 480 x 800 pixels, 24 bits (16.7 million pixels), 400 Nits.
Touch Panel	Multi-Touch projected capacitive; fingertip (bare or gloved) input; conductive stylus supported (sold separately)); Corning® Gorilla® Glass
Backlight	Configurable LED backlight control
Battery	PowerPrecision+ rechargeable 4.2 VDC 6,700 mAh Lithium-Ion battery. PowerPrecision+ rechargeable 4.2 VDC 7,000 mAh Lithium-Ion battery.
Backup Power	Hot Swap battery backup
Expansion Slot	SDHC up to 32 GB (FAT32 format); SDXC compliant microSD up to 128 GB (exFAT format).
Expansion Port	USB, Serial for ISV developers (optional)
Notifications	Audible tone plus multi-color LEDs and vibration
Voice and Audio	Dual Speakers, Bluetooth wireless headset support
<b>Performance Characteristics</b>	

## Specifications

Table 4 Technical Specifications (Continued)

Item	Description
CPU	Qualcomm Snapdragon™ 660 octa-core, 2.2 GHz
Operating System	Android-based AOSP and GMS V8.1 (Oreo) with Mobility Extensions (Mx), for true enterprise class operating system.
Memory	4 GB RAM: Base: 32 GB Flash (pSLC) Package 1: 32 GB Flash (pSLC) 8 GB RAM: Package 2: 128 GB Flash (pSLC)
Application Development	Zebra Android EMDK
<b>User Environment</b>	
Operating Temperature	-20° C to 50° C (-4° F to 122° F)
Storage Temperature	-40° C to 70° C (-40° F to 158° F)
Battery Charging Temperature	0° C to +40° C (32° F to 104° F) ambient temperature range.
Humidity	5% - 95% non-condensing
Drop Specification	Multiple 8 ft./2.4 m drop to concrete at room temperature per MIL-STD 810G; multiple 6 ft./1.8 m drop to concrete across full operating temperature range
Tumble	2,000 1 m (3.28 ft.) tumbles; meets and exceeds IEC tumble specifications
Sealing	IP65
Vibration	Sine 5-2000 Hz, 4 g peak, 1 hour per axis Random 20-2000 Hz, 6 g RMS or 0.04 g2/Hz, 1 hour per axis
ESD	± 20k VDC air discharge ± 10k VDC contact discharge ± 10k VDC indirect discharge
<b>Wireless LAN Data Communications</b>	
Radio	IEEE 802.11 a/b/g/n/ac/d/h/i/r/k/w; Wi-Fi™ certified; IPv4, IPv6, 2x2 MU-MIMO.
Data Rates	5GHz: 802.11a/n/ac - up to 866.7 Mbps 2.4GHz: 802.11b/g/n - up to 300 Mbps
Operating Channels	Channel 1-13 (2412-2472 MHz): 1,2,3,4,5,6,7,8,9,10,11,12,13 Channel 36-165 (5180-5825 MHz): 36,40,44,48,52,56,60,64,100,104,108,112,116,120,124,128,132,136,140,144,149,153,157,161,165 Channel Bandwidth: 20, 40, 80 MHz Actual operating channels/ frequencies and bandwidths depend on regulatory rules and certification agency.
Security and Encryption	WEP (40 or 104 bit); WPA/WPA2 Personal (TKIP, and AES); WPA/WPA2 Enterprise (TKIP and AES) - EAP-TTLS (PAP, MSCHAP, MSCHAPv2), EAP-TLS, PEAPv0-MSCHAPv2, PEAPv1-EAP-GTC and LEAP. EAP-PWD
Multimedia	Wi-Fi Multimedia™ (WMM)
Certifications	WFA (802.11n, WMM-PS, 801.11ac, PMF)
Fast Roam	PMKID Caching, Cisco CCKM, 802.11r, OKC.
<b>Wireless PAN Data Communications</b>	

## Specifications

*Table 4 Technical Specifications (Continued)*

Item	Description
Bluetooth	Class 2, Bluetooth 5.0, Bluetooth Low Energy (BLE)
USB	USB 2.0 Client for service and maintenance.
<b>Data Capture</b>	
Laser Scanning	SE965 1D standard range scan engine.
Imager	SE4770-SR standard range next generation omnidirectional 1D/2D imaging engine. SE4850-ER extended range imager
Camera	13 MP Autofocus with flash, f/2.4 aperture (optional).
NFC	Multi-Protocol NFC (optional).
Zebra Interactive Sensor Technology (IST)	
Motion Sensor	3-axis accelerometer; 3-axis gyroscope (optional).
Light Sensor	Automatically adjusts display backlight.
Proximity	Sensor for auto hands-free scanning (optional).

*Table 5 Data Capture Options*

Item	Description
1D Bar Codes	Chinese 2 of 5, Codabar, Code 11, Code 128, Code 39, Code 93, Discrete 2 of 5, EAN-8, EAN-13, GS1 DataBar, GS1 DataBar 14, GS1 DataBar Expanded GS1, GS1 DataBar Limited, Interleaved 2 of 5, Korean 2 of 5, Matrix 2 of 5, MSI, TLC39, Trioptic 39, UPCA, UPCE, UPCE 1
2D Bar Codes	Australian Postal, Aztec, Canadian Postal, Composite AB, Composite C, Data Matrix, DotCode, Dutch Postal, HAN XIN, Japanese Postal, Mail Mark, Maxi Code, Micro PDF-417, microQR, PDF-417, QR Code, US Planet, UK Postal, US Postnet, USPS 4-state (US4CB), US4state FICS

## SE965 Standard Range Laser Decode Zones

The table below lists the typical distances for selected bar code densities. The minimum element width (or “symbol density”) is the width in mils of the narrowest element (bar or space) in the symbol.

Table 6 SE965 Decode Distances

Symbol Density/ Bar Code Type/ W-N Ratio	Bar Code Content/ Contrast <sup>Note 1</sup>	Typical Working Ranges	
		Near	Far
5.0 mil Code 128	1234 80% MRD	1.2 in 3.05 cm	7.7 in 19.56 cm
5.0 mil Code 39; 2.5:1	ABCDEFGH 80% MRD	1.2 in 3.05 cm	12.5 in 31.75 cm
7.5 mil Code 39; 2.5:1	ABCDEF 80% MRD	1.1 in 2.79 cm	18.5 in 46.99 cm
10 mil Code 128	1234 80% MRD	1.2 in <sup>Note 3</sup> 3.05 cm <sup>Note 3</sup>	19.0 in 48.26 cm
13 mil 100% UPC	12345678905 80% MRD	1.6 in 4.06 cm	27.0 in 68.58 cm
15 mil Code 128	1234 80% MRD	1.0 in <sup>Note 3</sup> 2.54 cm <sup>Note 3</sup>	29.5 in 74.93 cm
20 mil Code 39; 2.2:1	123 80% MRD	1.4 in <sup>Note 3</sup> 3.56 cm <sup>Note 3</sup>	52.0 in 132.08 cm
55 mil Code 39; 2.2:1	CD 80% MRD	3.4 in <sup>Note 3</sup> 8.64 cm <sup>Note 3</sup>	100.0 in 254.00 cm
100 mil Code 39; 3.0:1 reflective	123456 80% MRD	2 ft <sup>Note 3</sup> 60.96 cm <sup>Note 3</sup>	17 ft 518.16 cm

Notes:

1. Contrast measured as Mean Reflective Difference (MRD) at 650 nm.
2. Working range specifications at ambient temperature (23°C), photographic quality symbols. Pitch=10°, roll=0°, skew=0°, ambient light < 150 ft-candles using Symbol or equivalent decoder.
3. Dependent on width of bar code.
4. Distances measured from front edge of scan engine chassis.



## SE4750-MR Decode Zones

The table below lists the typical distances for selected bar code densities.

**Table 7** SE4750-MR Decode Distances

Symbology	Typical Working Range	
	Near	Far
5 mil Code 128	7.4 in. 18.8 cm	16.0 in. 40.6 cm
5 mil PDF417	8.1 in. 20.6 cm	13.1 in. 33.3 cm
7.5 mil Data Matrix	8.3 in. 21.1 cm	12.8 in. 32.5 cm
10 mil Data Matrix	7.0 in. 17.8 cm	17.0 in. 43.2 cm
13 mil UPCA	2.3* in. 5.8* cm	38.0 in. 96.5 cm
15 mil Code 128	4.0* in. 10.2* cm	40.0 in. 101.6 cm
20 mil Code 39	2.1* in. 5.3* cm	54.0 in. 137.2 cm
100 mil Code 39	11.0 in. 27.9 cm	172.0 in. 436.9 cm
160 mil Data Matrix	11.5 in. 29.2 cm	138.0 in. 350.5 cm

\* Limited by width of bar code in field of view.

Note: Photographic quality bar code at 18° tilt pitch angle under 30 fcd ambient illumination. Distances measured from front edge of scan engine chassis.

## SE4750-DP Decode Zones

The table below lists the typical distances for selected bar code densities.

**Table 8** SE4750-DP Decode Distances

Symbology	Typical Working Range	
	Near	Far
3 mil Code 39	1.7 in. 4.3 cm	4.3 in. 10.9 cm
5 mil PDF417	1.7 in. 4.3 cm	4.3 in. 10.9 cm
6.67 mil PDF417	1.7* in. 4.3 cm	4.7 in. 11.9 cm
5 mil Data Matrix	1.9 in. 4.8 cm	4.0 in. 10.2 cm
10 mil Data Matrix	1.6 in. 4.1 cm	4.9 in. 12.5 cm
5 mil QR Code	1.9 in. 4.8 cm	4.0 in. 10.2 cm
10 mil QR	1.1 in. 2.6 cm	5.0 in. 12.7 cm
13.0 mil 100% UPC	2.4* in. 6.1* cm	7.3 in. 18.5 cm

\* Limited by width of bar code in field of view.  
 Note: Photographic quality barcode 30 fcd ambient illumination.  
 Distances measured with DPM Mode Off.

## SE4750-DPW Decode Zones

The table below lists the typical distances for selected bar code densities.

**Table 9** SE4750-DPW Decode Distances

Symbology	Typical Working Range	
	Near	Far
5 mil Code 39	1.4 in. 3.6 cm	7.0 in. 17.8 cm
15 mil Code 128	4.7 in. 11.9 cm	12.5 in. 31.8 cm
5 mil PDF417	1.7 in. 4.3 cm	4.3 in. 10.9 cm
6.67 PDF417	1.4 in. 3.6 cm	5.5 in. 14.0 cm
10 mil Data Matrix	1.4 in. 3.6 cm	6.1 in. 15.5 cm
10 mil QR	1.4 in. 3.6 cm	6.1 in. 15.5 cm
13.0 mil 100% UPC	1.8 in. 4.6 cm	12.0 in. 30.5 cm

\* Limited by width of bar code in field of view.  
 Note: Photographic quality barcode 30 fcd ambient illumination.  
 Distances measured with DPM Mode Off.

## SE4770-SR Decode Zones

The table below lists the typical distances for selected bar code densities.

Table 10 SE4770-SR Decode Distances

Symbology	Typical Working Range	
	Near	Far
3 mil Code 39	3.0 in. 7.6 cm	5.8 in. 14.7 cm
5 mil Code 128	2.3 in. 5.8 cm	9.8 in. 24.9 cm
5 mil PDF417	3.0 in. 7.6 cm	7.9 in. 20.1 cm
6.67 mil PDF 417	2.5 in. 6.4 cm	10.1 in. 25.7 cm
10 mil DataMatrix	2.1 in. 5.3 cm	11.0 in. 27.9 cm
100% UPCA	1.6 in. 4.1 cm	24.9 in. 63.2 cm
15 mil Code 128	2.4 in. 6.1* cm	27.8 in. 70.1 cm
20 mil Code 39	1.6 in. 4.1 cm	36.1 in. 91.7 cm
20 mil QR	1.1 in. 2.8 cm	17.5 in. 44.5 cm

\* Limited by width of bar code in field of view.

Note: Photographic quality bar code at 18° tilt pitch angle under 30 fcd ambient illumination. Distances measured from front edge of scan engine chassis.

## SE4850 Decode Zones

The table below lists the typical distances for selected bar code densities.

Table 11 SE4850 Decode Distances

Symbology	Typical Working Range @20 Ft-Cd Minimum	
	Near	Far
10 mil Code 39	3.0 in. * 7.6 cm *	85.0 in. 215.9 cm
13 100% UPC	3.5 in. 8.9 cm	90.0 in. 228.6 cm
15 mil Code 128	6.0 in. * 15.2 cm *	100.0 in. 254.0 cm
20 mil Code 39	4.0 in. * 10.2 cm *	172.0 in. 436.9 cm
40 mil Code 39	6.0 in. * 15.2 cm *	340.0 in. ** 863.6 cm **
55 mil Code 39	7.0* in. * 17.8* cm *	430.0 in. ** 1092.2 cm **
100 mil Code 39 (paper)	20.0* in. * 50.8* cm *	700.0 in. ** 1778.0 cm **
100 mil Code 128 (reflective)	30.0 in. * 76.2 cm *	700.0 in. 1778.0 cm
DataMatrix 10	5.0 in. 12.7 cm	45.0 in. 114.3 cm
DataMatrix 55	5.0 in. 12.7 cm	250.0 in. 635.0 cm
15 mil Code 128 (4 in. wide)	8.0 in. * 20.3 cm *	100.0 in. 254.0 cm

\* Limited by width of bar code in field of view.  
 \*\* Range is reduced under low ambient light level.

## I/O Connector Pin-Outs

Figure 28 I/O Connector

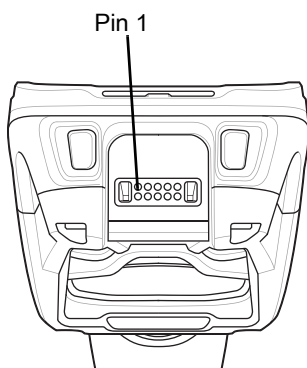


Table 12 I/O Connector Pin-Outs

Pin	Signal	Description
1	DGND	Digital ground
2	MUX_RX_HMIC	External headset microphone/RX
3	POWER_IN	Adapter voltage in
4	HST_PLUGDETN	Headset or accessory detection
5	DGND	Audio path Ground
6	USB_ID	USB OTG ID pin.
7	MUX_TX_HSL	External headset speaker/TX
8	USB_PWR	USB VBUS Power
9	OTG_DP	USB OTG D+
10	OTG_DM	USB OTG D-

## 2-Slot USB Charge Cradle Technical Specifications

Table 13 2-Slot USB Charge Cradle Technical Specifications

Item	Description
Dimensions	Height: 137.5 mm (5.41 in.) Width: 195.6 mm (7.70 in.) Depth: 134.5 mm (5.29 in.)
Weight	838 g (29.6 oz.)
Input Voltage	12 VDC
Power Consumption	20 watts
Operating Temperature	0 °C to 50 °C (32 °F to 122 °F)
Storage Temperature	-40 °C to 70 °C (-40 °F to 158 °F)
Charging Temperature	0 °C to 40 °C (32 °F to 104 °F)
Humidity	5% to 95% non-condensing
Drop	76.2 cm (30.0 in.) drops to vinyl tiled concrete at room temperature.
Electrostatic Discharge (ESD)	+/- 20kV air +/- 10 kV contact +/- 10 kV indirect discharge

## 2-Slot DPM USB Charge Cradle Technical Specifications

Table 14 2-Slot DPM USB Charge Cradle Technical Specifications

Item	Description
Dimensions	Height: 137.5 mm (5.41 in.) Width: 195.6 mm (7.70 in.) Depth: 134.5 mm (5.29 in.)
Weight	838 g (29.6 oz.)
Input Voltage	12 VDC
Power Consumption	20 watts
Operating Temperature	0 °C to 50 °C (32 °F to 122 °F)
Storage Temperature	-40 °C to 70 °C (-40 °F to 158 °F)
Charging Temperature	0 °C to 40 °C (32 °F to 104 °F)
Humidity	5% to 95% non-condensing
Drop	76.2 cm (30.0 in.) drops to vinyl tiled concrete at room temperature.
Electrostatic Discharge (ESD)	+/- 20kV air +/- 10 kV contact +/- 10 kV indirect discharge

## 5-Slot Charge Only Cradle Technical Specifications

Table 15 5-Slot Charge Only Cradle Technical Specifications

Item	Description
Dimensions	Height: 108.1 mm (4.26 in.) Width: 489.0 mm (19.25 in.) Depth: 134.5 mm (5.30 in.)
Weight	2.14 kg (4.71 lbs.)
Input Voltage	12 VDC
Power Consumption	60 watts
Operating Temperature	0 °C to 50 °C (32 °F to 122 °F)
Storage Temperature	-40 °C to 70 °C (-40 °F to 158 °F)
Charging Temperature	0 °C to 40 °C (32 °F to 104 °F)
Humidity	0% to 95% non-condensing
Drop	76.2 cm (30.0 in.) drops to vinyl tiled concrete at room temperature.
Electrostatic Discharge (ESD)	+/- 20kV air +/- 10kV contact +/- 10kV indirect discharge



## 5-Slot Charge Only Cradle with Battery Charger Technical Specifications

Table 16 5-Slot Charge Only Cradle with Battery Charger Technical Specifications

Item	Description
Dimensions	Height: 137.0 mm (5.39 in.) Width: 489.0 mm (19.25 in.) Depth: 134.5 mm (5.30 in.)
Weight	2.33 kg (5.13 lbs.)
Input Voltage	12 VDC
Power Consumption	75 watts
Operating Temperature	0 °C to 50 °C (32 °F to 122 °F)
Storage Temperature	-40 °C to 70 °C (-40 °F to 158 °F)
Charging Temperature	0 °C to 40 °C (32 °F to 104 °F)
Humidity	0% to 95% non-condensing
Drop	76.2 cm (30.0 in.) drops to vinyl tiled concrete at room temperature.
Electrostatic Discharge (ESD)	+/- 20kV air +/- 10kV contact +/- 10kV indirect discharge

## 5-Slot Ethernet Cradle Technical Specifications

Table 17 5-Slot Ethernet Cradle Technical Specifications

Item	Description
Dimensions	Height: 108.1 mm (4.26 in.) Width: 489.0 mm (19.25 in.) Depth: 134.5 mm (5.30 in.)
Weight	2.22 kg (4.89 lbs.)
Input Voltage	12 VDC
Power Consumption	67 watts
Operating Temperature	0 °C to 50 °C (32 °F to 122 °F)
Storage Temperature	-40 °C to 70 °C (-40 °F to 158 °F)
Charging Temperature	0 °C to 40 °C (32 °F to 104 °F)
Humidity	5% to 95% non-condensing
Drop	76.2 cm (30.0 in.) drops to vinyl tiled concrete at room temperature.
Electrostatic Discharge (ESD)	+/- 20kV air +/- 10kV contact +/- 10kV indirect discharge

## 5-Slot Ethernet Cradle with Battery Charger Technical Specifications

Table 18 5-Slot Ethernet Cradle with Battery Charger Technical Specifications

Item	Description
Dimensions	Height: 137.0 mm (5.39 in.) Width: 489.0 mm (19.25 in.) Depth: 134.5 mm (5.30 in.)
Weight	2.36 kg (5.20 lbs.)
Input Voltage	12 VDC
Power Consumption	82 watts
Operating Temperature	0 °C to 50 °C (32 °F to 122 °F)
Storage Temperature	-40 °C to 70 °C (-40 °F to 158 °F)
Charging Temperature	0 °C to 40 °C (32 °F to 104 °F)
Humidity	5% to 95% non-condensing
Drop	76.2 cm (30.0 in.) drops to vinyl tiled concrete at room temperature.
Electrostatic Discharge (ESD)	+/- 20kV air +/- 10kV contact +/- 10kV indirect discharge

## 4-Slot Battery Charger Technical Specifications

Table 19 4-Slot Battery Charger Technical Specifications

Item	Description
Dimensions	Height: 129.6 mm (5.10 in.) Width: 97.5 mm (3.84 in.) Depth: 134.5 mm (5.30 in.)
Weight	570 g (20.11 oz.)
Input Voltage	12 VDC
Power Consumption	27 watts
Operating Temperature	0 °C to 40 °C (32 °F to 104 °F)
Storage Temperature	-40 °C to 70 °C (-40 °F to 158 °F)
Charging Temperature	0 °C to 40 °C (32 °F to 104 °F)
Humidity	5% to 95% non-condensing
Drop	76.2 cm (30.0 in.) drops to vinyl tiled concrete at room temperature.
Electrostatic Discharge (ESD)	+/- 20kV air +/- 10kV contact +/- 10kV indirect discharge

## USB and Charging Cable Technical Specifications

Table 20 USB and Charging Cable Technical Specifications

Item	Description
Length	150 cm (5.90 in.)
Input Voltage	5.4 VDC (external power supply)
Operating Temperature	-20 °C to 50 °C (-4 °F to 122 °F)
Storage Temperature	-40 °C to 70 °C (-40 °F to 158 °F)
Humidity	10% to 95% non-condensing
Electrostatic Discharge (ESD)	+/- 20kV air +/- 10kV contact

## Quick Disconnect Audio Cable Technical Specifications

Table 21 Quick Disconnect Audio Cable Technical Specifications

Item	Description
Length	40 cm (15.75 in.)
Input Voltage	5.4 VDC
Operating Temperature	-20 °C to 50 °C (-4 °F to 122 °F)
Storage Temperature	-40 °C to 70 °C (-40 °F to 158 °F)
Humidity	10% to 95% non-condensing
Electrostatic Discharge (ESD)	+/- 20kV air +/- 10kV contact

## 3.5 mm Audio Cable Technical Specifications

Table 22 3.5 mm Audio Cable Technical Specifications

Item	Description
Length	21.7 cm (8.54 in.)
Operating Temperature	-20 °C to 50 °C (-4 °F to 122 °F)
Storage Temperature	-40 °C to 70 °C (-40 °F to 158 °F)
Humidity	10% to 95% non-condensing
Electrostatic Discharge (ESD)	+/- 20kV air +/- 10kV contact

# Index

## Numerics

2-slot USB charge cradle . . . . . 30

## A

### accessories

2-slot USB charge cradle . . . . . 30

four slot charge only cradle . . . . . 34, 36, 39, 45

advanced data formatting rules . . . . . 111

approved cleanser . . . . . 168

approved cleanser active ingredients . . . . . 168

### apps

RxLogger . . . . . 139

RxLogger Utility . . . . . 147

## B

barcode input . . . . . 85

enabled . . . . . 85

battery charging temperature . . . . . 174

battery safety guidelines . . . . . 167

## C

cleaning . . . . . 168, 169

battery connectors . . . . . 170

camera and exit window . . . . . 170

cradle connectors . . . . . 170

display . . . . . 170

frequency . . . . . 169

housing . . . . . 169

instructions . . . . . 168

materials . . . . . 169

cleaning instructions . . . . . 169

configuration . . . . . 11

CPU . . . . . 174

### cradle

connector cleaning . . . . . 170

### cradles

2-slot . . . . . 30

four slot charge only . . . . . 34, 36, 39, 45

## D

data capture plus . . . . . 83

### datawedge

accessing . . . . . 77

advanced data formatting rules . . . . . 111

APIs . . . . . 123

associating applications . . . . . 82

auto import . . . . . 122

auto switch to default on event . . . . . 86

barcode input . . . . . 85

basic scanning . . . . . 77

configuration and profile file management . . . . . 121

configuring ADF plug-in . . . . . 111

creating a new profile . . . . . 80

data capture plus . . . . . 83

decoders . . . . . 87

disabling . . . . . 80

enterprise folder . . . . . 121

exporting a configuration file . . . . . 120

hardware trigger . . . . . 86

importing a configuration file . . . . . 120

input plugins . . . . . 78

intent output . . . . . 105

intent overview . . . . . 106

introduction . . . . . 77

IP output . . . . . 107

keep enabled on suspend . . . . . 103

keystroke output . . . . . 104

multibarcodes params . . . . . 103

options menu . . . . . 80

output plug-ins . . . . . 79

plug-ins . . . . . 78

process plug-ins . . . . . 78

profile configuration . . . . . 81

profile context menu . . . . . 79

profile0 . . . . . 78

profiles . . . . . 77

profiles screen . . . . . 79

programming notes . . . . . 122

reader params . . . . . 98

reporting . . . . . 122



T

transferring files using USB .....75  
troubleshooting .....171

U

UDI params .....102  
unpacking .....16  
UPC EAN params .....95  
USB .....75

V

voice input .....103

W

weight .....173  
WLAN radio .....174

