

TLM-B061-T/T-2109-01

**TAMRON** | Model: B061 Owner's manual

**18-300mm F/3.5-6.3 Di III-A VC VXD**

For Sony E (APS-C)  
For FUJIFILM X (APS-C)

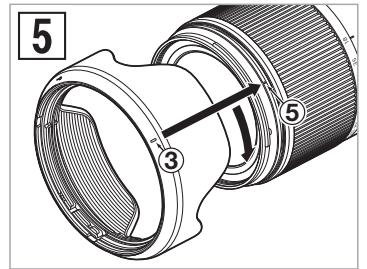
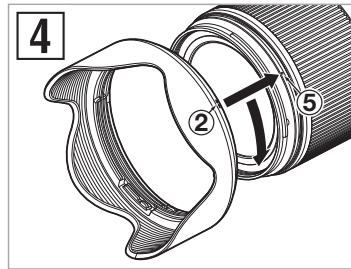
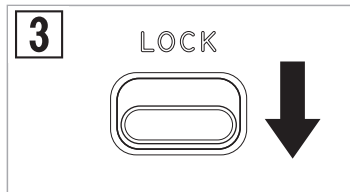
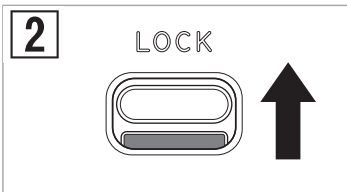
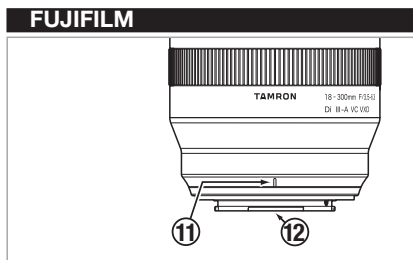
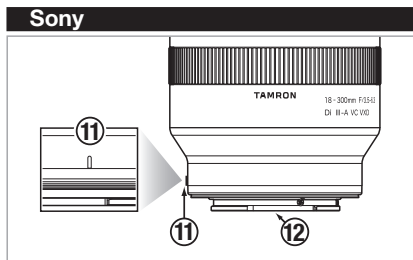
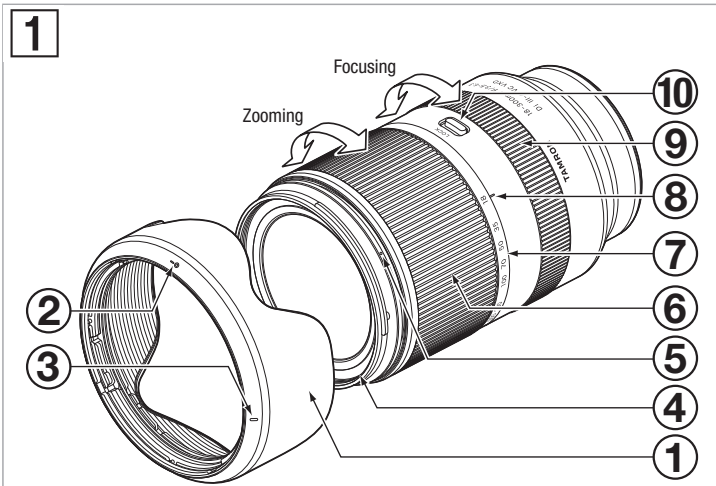

**For FUJIFILM X Mount Lens**

FreeRTOS Kernel V10.3.1

Copyright (C) 2020 Amazon.com, Inc. or its affiliates. All Rights Reserved.

Permission is hereby granted, free of charge, to any person obtaining a copy of this software and associated documentation files (the "Software"), to deal in the Software without restriction, including without limitation the rights to use, copy, modify, merge, publish, distribute, sublicense, and/or sell copies of the Software, and to permit persons to whom the Software is furnished to do so, subject to the following conditions:

The above copyright notice and this permission notice shall be included in all copies or substantial portions of the Software.

THE SOFTWARE IS PROVIDED "AS IS", WITHOUT WARRANTY OF ANY KIND, EXPRESS OR IMPLIED, INCLUDING BUT NOT LIMITED TO THE WARRANTIES OF MERCHANTABILITY, FITNESS FOR A PARTICULAR PURPOSE AND NONINFRINGEMENT. IN NO EVENT SHALL THE AUTHORS OR COPYRIGHT HOLDERS BE LIABLE FOR ANY CLAIM, DAMAGES OR OTHER LIABILITY, WHETHER IN AN ACTION OF CONTRACT, TORT OR OTHERWISE, ARISING FROM, OUT OF OR IN CONNECTION WITH THE SOFTWARE OR THE USE OR OTHER DEALINGS IN THE SOFTWARE.

<http://www.FreeRTOS.org>  
<http://aws.amazon.com/freertos>

- CE** \* The **CE** Marking is a directive conformity mark of the European Community (EC).
- \* Das **CE**-Zeichen entspricht der EC Norm.
- \* La marquage **CE** est un marquage de conformité à la directive CEE (CE).
- \* La marca **CE** es marca de conformidad según directiva de la Comunidad Europea (CE).
- \* Il marchio **CE** attesta la conformità alla direttiva della Comunità Europea (CEE).
- \* **CE** 标志表示符合欧洲共同体(CE)指标

**CE** The EEC Conformity Report applies to the Council Directive 2014/30/EU, 2011/65/EU and is used by Tamron Co., Ltd., manufacturer of this product.

# ENGLISH

Thank you for purchasing this Tamron lens. Before using your new lens, please read the contents of this Owner's manual to properly use the lens. Also, it will be important to read the manual of the camera to which you will attach the lens.

After reading, store this Owner's manual in a safe place.

Please read also the document "Precautions for Safe Use of Tamron Lenses" supplied with the lens for the detailed safety precautions to observe when using Tamron lenses.



- Explains precautions that help to prevent problems.



- Explains things you should know in addition to basic operations.

## PART NAMES (Refer to Fig. 1)

- |                        |                                  |
|------------------------|----------------------------------|
| ① Lens hood            | ② Hood attaching alignment mark  |
| ③ Hood locking mark    | ④ Filter ring                    |
| ⑤ Hood release mark    | ⑥ Zooming ring                   |
| ⑦ Focal length scale   | ⑧ Focal length mark              |
| ⑨ Focus ring           | ⑩ Zoom lock switch               |
| ⑪ Lens attachment mark | ⑫ Lens-camera interface contacts |

## MAIN SPECIFICATIONS

Model	B061
Focal Length	18 - 300 mm
Maximum Aperture	F/3.5-6.3
Angle of View (diagonal)	77°24' - 5°30'
Optical Construction	15/19
Minimum Object Distance (MOD)	0.15 m *1 (5.9") (Wide) / 0.99 m (39.0") (Tele)
Maximum Magnification Ratio	1:2 (Wide MOD) / 1:4 (Tele MOD)
Filter Size	ø 67 mm
Length	125.6 mm (4.9") / Sony E, 125.8 mm (5.0") / FUJIFILM X
Maximum Diameter	ø 75.5 mm
Weight	620 g (21.9 oz)
Lens Hood	HA036



- Length : From tip of front element to mount surface.
- Specifications, appearance, functionality, etc. are subject to change without prior notice.
- \*1 Please note, when shooting between 0.15 m (5.9") to 0.2 m (7.9") distance, the image quality at periphery will decrease. It is recommended that you place your focus at center of image. Also, pay attention to your lens filter and lens tip when shooting at close range. You may touch your subject.

## ATTACHING AND REMOVING THE LENS

Remove the rear cap of the lens. Align the lens attachment mark ⑪ and mounting mark on the camera, and then insert the lens.

Turn the lens clockwise until it locks.

To remove the lens, turn the lens in the opposite direction while pressing the lens release button on the camera.



- Turn off the power of the camera before attaching or removing the lens.



- For details, please read the instruction manual of your camera.

## SWITCHING FOCUS MODE

Select the desired focus mode on the camera.

For manual focusing, turn the focus ring ⑨ to acquire the desired focus.

For details, please read the instruction manual of your camera.



- Under AF mode, there may be difficulty for autofocus to work depending on the subject.

## VIBRATION COMPENSATION MECHANISM

To compensate for the vibrations, enable the vibration compensation setting of the camera.

\* Under video recording setting, the lens switches automatically to a vibration compensation mode suitable for videos.

### • Vibration compensation is effective under the following conditions

- Dimly lit locations
- Locations where flash photography is prohibited
- Locations where tripod cannot be used

### • Vibrations may not be compensated sufficiently under the following conditions

- When a photograph is taken from a vehicle that is shaking greatly
- Shooting during excessive movement of the camera
- When shooting while using a tripod
- Disable the vibration compensation setting of the camera when taking pictures with bulb photography (long exposures). Otherwise, vibration compensation may cause a malfunction.



- The viewfinder image may become blurred immediately after the shutter button is pressed halfway. This is due to the principles of the vibration compensation mechanism and not a malfunction.
- Disable the vibration compensation setting of the camera when you are shooting while the camera is secured by something other than your hand (such as a tripod).
- You may feel the lens rattle when the camera is turned off or when the lens is removed from the camera. This is not a malfunction.



- For details, please read the instruction manual of your camera.

## ZOOMING (Ref. Fig. 1)

Turn the zooming ring ⑥ to adjust the focal length (Zoom position) to a desired position.

## ZOOM LOCK MECHANISM (Ref. Figs. 1, 2, 3)

You can lock the zooming ring ⑥ at a focal length of 18mm to keep it from rotating.

### ■ Setting the zoom lock (Ref. Fig. 2)

Align 18mm on the focal length scale ⑦ with the focal length mark ⑧.

Set the zoom lock switch ⑩ toward the zooming ring.

### ■ Releasing the zoom lock (Ref. Fig. 3)

Set the zoom lock switch ⑩ toward the camera.



- To zoom, release the lock, and then rotate the zooming ring.

## LENS HOOD (Ref. Figs. 1, 4, 5)

The hood ① can eliminate stray light that may affect the picture.

### ■ Using the lens hood (Ref. Fig. 4)

Align the hood attaching alignment mark ② of the hood with the hood release mark ⑤ of the lens.

Rotate the hood ① in the direction of the arrow until the hood locking mark ③ meets the hood release mark ⑤.

### ■ Stowing the lens hood (Ref. Fig. 5)

Attach the hood ① in reverse and rotate it until it locks.



- Be aware that the periphery of the photographed image may be darkened if the hood ① is not attached properly.

## USAGE PRECAUTIONS

- An internal focusing (IF) system is employed to reduce the minimum focus distance. The angle of view may be wider than that of lenses with other focusing systems when shooting at a distance less than infinity.
- The lens hood or the lens barrel may block the light from the flash. It is recommended to perform trial shooting in advance.
- Differences in the display systems of cameras may cause to show values different from the maximum and minimum aperture values from the specifications. This is not an indication of an error.
- Do not touch the lens-camera interface contacts with your fingers. Otherwise, it may cause a malfunction.
- If the temperature changes suddenly, condensation may form and cause malfunctions.
- The front element is covered with stain-proof coating. After removing the dust on the lens surface with a blower or another means, wipe it with a dry cloth.
- Never use benzene, thinner, or other organic solvents to clean the lens.
- Store the lens in a clean and well-ventilated place.
- For more details on the lens cleaning and storage, the compatibility with cameras, and other support information see our website. <https://www.tamron.jp/en/support/>



### Disposal of Electrical and Electronic Equipment in Private Households. Disposal of used Electrical & Electronic Equipment (Applicable in the European Union and other European countries with separate collection systems)

This symbol indicates that this product shall not be treated as household waste. Instead it shall be collected separately for the recycling of electrical and electronic equipment.

If the new products are purchased, this product might be handed over to the distributor or the collection system of waste electrical and electronic equipment eventually.

By ensuring this product is disposed of correctly, you will help prevent potential negative consequences for the environment and human health, which could otherwise be caused by inappropriate waste handling of this product or components of this product.

If this product is disposed illegally, it might cause a possibility of penalties. For more detailed information about recycling of this product, please contact your local Civic Office, your household waste disposal service or the shop where you purchased the product.

# TAMRON

# ENGLISH

## Precautions for Safe Use of Tamron Lenses

For safe operation be sure to carefully read the "Precautions for Safe Use of Tamron Lenses" and the manual before using the product.

After reading them, store them in a place where they can easily be reviewed whenever needed.

Caution instructions are divided into the following two categories according to the degree of danger involved.



### WARNING

This indicates instructions which if not followed or if performed incorrectly could lead to death or serious injury.

- Do not view the sun or other strong light source directly through the lens or through a camera while using this lens.  
Doing so could cause loss of vision, damage to the lens and/or the camera, and possibly cause the lens and/or camera to ignite.
- Do not disassemble, repair, or modify the lens.  
This could damage the lens or camera.
- Keep the lens out of the reach of small children.  
There is a risk of injury if the lens is dropped or falls down.



### CAUTION

This indicates instructions which if not heeded or if performed incorrectly could lead to bodily injury or physical damage

- Do not place lens in direct sunlight or leave it in an extremely hot place such inside a car. Doing such could damage the internal parts of the lens or cause a fire.
- Always attach the lens cap whenever the lens is not in use.
- When attaching the lens to the camera, ensure that the lens has been properly attached to the camera and firmly locked.  
If the lens is not attached properly, it could be difficult to remove or it could fall off causing damage or injury.
- Do not use this lens for any application other than photography.
- Do not transport the lens while it is still attached to a tripod.