

Table of Contents

GB-IE

1. Precautions for safety and use	20
2. Fitting the appliance in the top	21
2.1 Fixing to the supporting structure	21
3. Electrical connection	23
4. Gas connection	24
4.1 Bottled gas connection	25
4.2 Room ventilation	25
4.3 Combustion gas discharge	25
5. Adapting to different types of gas	26
5.1 Removing the hob skin	26
5.2 Adjusting for bottled gas	27
5.3 Adjusting for town gas	27
5.4 Adjusting for natural gas	28
5.5 Adjusting the primary air flow	28
5.6 Reassembling the hob skin	28
5.7 Adjusting the minimum setting for natural gas and town gas	29
5.8 Adjusting the minimum for bottled gas	29
5.9 Hob burner layout	29
5.10 Greasing the gas taps	29
6. Description of controls	30
6.1 The front panel	30
7. Using the hob	31
7.1 Lighting burners with safety device	31
7.2 Positioning the griddle plate	31
7.3 Practical hints for using the burners	31
7.4 Pan diameters	32
8. Cleaning and maintenance	33
8.1 Cleaning stainless steel	33
8.2 Cleaning the components	33

THESE INSTRUCTIONS ONLY APPLY TO THE COUNTRIES OF DESTINATION WHOSE IDENTIFICATION SYMBOLS ARE LISTED ON THE COVER OF THIS MANUAL.
THIS BUILT-IN HOB IS CLASSIFIED AS CLASS 3.



INSTRUCTIONS FOR THE INSTALLER: these are intended for the **qualified engineer** who is to check the gas supply system and install, commission and test the appliance.



INSTRUCTIONS FOR THE USER: these provide recommendations for use, a description of the controls and the correct procedures for cleaning and maintaining the appliance.

1. Precautions for safety and use



THIS MANUAL IS AN INTEGRAL PART OF THE APPLIANCE. TAKE GOOD CARE OF IT AND KEEP IT TO HAND THROUGHOUT THE HOB'S LIFE CYCLE. USERS ARE ADVISED TO READ THIS MANUAL AND ALL THE INSTRUCTIONS IT CONTAINS BEFORE USING THE HOB. ALSO KEEP THE SET OF NOZZLES PROVIDED IN A SAFE PLACE. INSTALLATION MUST BE CARRIED OUT BY QUALIFIED STAFF IN COMPLIANCE WITH THE RELEVANT REGULATIONS. THIS APPLIANCE IS INTENDED FOR HOUSEHOLD USE AND COMPLIES WITH THE EEC DIRECTIVES CURRENTLY IN FORCE. THE APPLIANCE IS BUILT TO PROVIDE THE FOLLOWING FUNCTION: COOKING AND HEATING FOODS; ALL OTHER USES ARE TO BE CONSIDERED IMPROPER. THE MANUFACTURER DECLINES ALL LIABILITY FOR USES OTHER THAN THOSE STATED ABOVE.



NEVER LEAVE PACKAGING RESIDUES UNATTENDED IN THE HOME. SEPARATE WASTE PACKAGING MATERIALS BY TYPE AND CONSIGN THEM TO THE NEAREST SEPARATE DISPOSAL CENTRE.



THE APPLIANCE MUST BE CONNECTED TO EARTH IN COMPLIANCE WITH ELECTRICAL SYSTEM SAFETY REGULATIONS.



THE PLUG TO BE CONNECTED TO THE POWER SUPPLY LEAD AND THE RELATIVE SOCKET MUST BE OF THE SAME TYPE AND COMPLY WITH THE RELEVANT REGULATIONS. THE POWER SUPPLY SOCKET MUST BE ACCESSIBLE EVEN AFTER THE APPLIANCE HAS BEEN BUILT-IN.

NEVER DISCONNECT THE PLUG BY PULLING ON THE POWER SUPPLY LEAD.



IMMEDIATELY AFTER INSTALLATION, CARRY OUT A QUICK TEST ON THE HOB FOLLOWING THE INSTRUCTIONS PROVIDED LATER IN THIS MANUAL. IF THE APPLIANCE FAILS TO OPERATE, DISCONNECT IT FROM THE ELECTRICAL MAINS AND CONTACT YOUR NEAREST SERVICE CENTRE.

NEVER ATTEMPT TO REPAIR THE APPLIANCE YOURSELF.



AFTER EACH USE OF THE HOB, ALWAYS CHECK THAT THE CONTROL KNOBS ARE TURNED TO "ZERO" (OFF).



NEVER PLACE PANS WITH BOTTOMS WHICH ARE NOT PERFECTLY FLAT AND SMOOTH ON THE HOB PAN STANDS.



NEVER USE PANS OR GRIDDLE PLATES WHICH PROJECT BEYOND THE OUTSIDE EDGE OF THE HOB.



THE NAMEPLATE WITH THE TECHNICAL DATA, SERIAL NUMBER AND MARK IS IN A VISIBLE POSITION UNDERNEATH THE CASING, ANNEXED TO THIS MANUAL AND APPLIED TO THE QUALITY CERTIFICATE.

THIS NAMEPLATE MUST NEVER BE REMOVED.



THE APPLIANCE IS INTENDED FOR USE BY ADULTS. KEEP CHILDREN AT A SAFE DISTANCE AND NEVER ALLOW THEM TO PLAY WITH IT.



THIS APPLIANCE IS TAGGED UNDER EUROPEAN DIRECTIVE 2002/96/EC ON WASTE ELECTRICAL AND ELECTRONIC EQUIPMENT (WEEE).

THIS DIRECTIVE CONTAINS THE REGULATIONS GOVERNING THE COLLECTION AND RECYCLING OF DECOMMISSIONED APPLIANCES THROUGHOUT THE EUROPEAN FITTING.



The manufacturer declines all responsibility for injury or damage caused by failure to comply with the above regulations or deriving from tampering with even just one part of the appliance and the use of non-original spare parts.



2. Fitting the appliance in the top



The procedures required below must be carried out by a skilled builder and/or joiner. The hob can be installed on various materials, including masonry, metal, solid wood and wood finished with plastic laminates, provided the material is heat-resistant ($T 90^{\circ} C$).

2.1 Fixing to the supporting structure

Make a hole in the cabinet top with the dimensions shown here, maintaining a distance of at least **50 mm** from the rear edge. This appliance may be installed against walls higher than the worktop surface, provided the distance "X" shown here is maintained, in order to prevent damage due to overheating. Make sure that there is at least **750 mm** between the hob burners and a shelf or hood (if any) placed vertically above them.

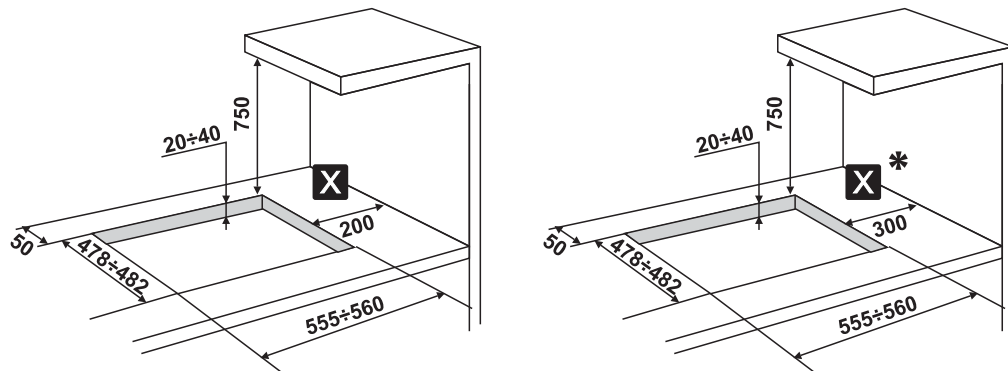

(*:6 Burner Hob, UR2 at Side)

If the hob is installed above a cupboard with doors, a separator panel must be installed underneath it. Leave a gap of at least 10 mm between the bottom of the hob and the surface of the panel, which must be easily removable to allow sufficient access for any servicing procedures.



Installation of an oven without cooling fan underneath the hob is forbidden.



*In case of installation on a hollow compartment with doors, a separating panel has to be placed under the hob. Keep a minimum distance of **10 mm** between the bottom of the unit and the panel surface. The panel has to be easily removable to allow access in the event of technical service.*

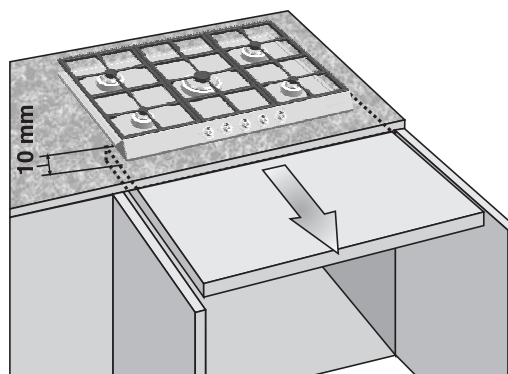



Instructions for the Installer

Fit the insulating gasket provided carefully around the outside edge of the hole made in the top as shown below, pressing it down with your hands so that its entire surface fits snugly. Follow the dimensions shown, depending on the model of hob to be installed, bearing in mind that on both models the long front edge must be flush with the hole. Fix the hob to the structure using the brackets **A** provided. Carefully trim off the excess edge of the gasket **B**. The dimensions in the drawing below refer to the hole **on the inside edge** of the gasket.

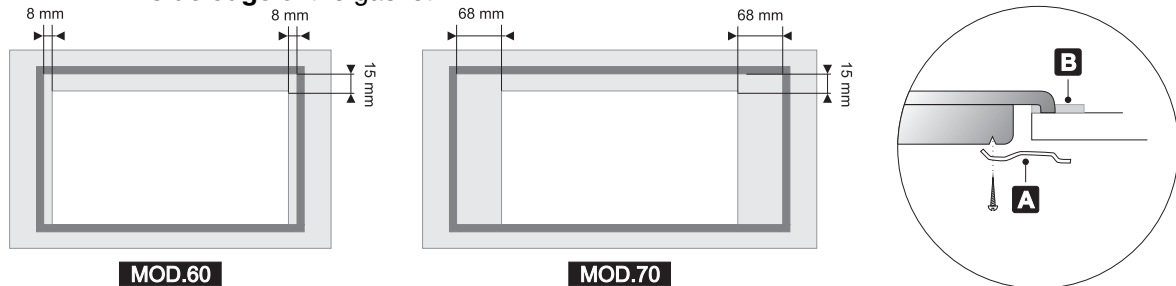

See right for the precise holes to be used when securing the hob to the top correctly using the brackets.

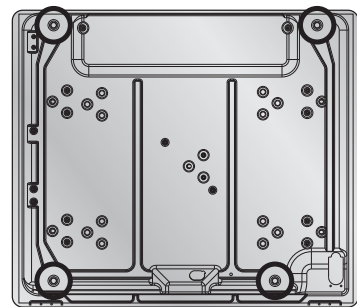



3. *Electrical connection*



Check that the power supply line voltage and size are as specified on the nameplate underneath the appliance's casing. **This nameplate must never be removed.**

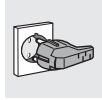

The plug on the end of the power supply lead and the wall socket must be of the same type and comply with the relevant regulations. Check that the power supply line is properly earthed.

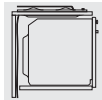

Pass the power supply cable through the rear of the cabinet, taking care that it does not touch the bottom case of the hob, or the oven (if any) built in underneath it.



The appliance's power supply line must be fitted with an omnipolar breaking device with contact gap of at least **3 mm**, located in an easily accessible position close to the appliance itself.

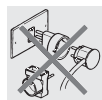

The use of reductions, adapters or junctions is not recommended.



If the power supply cable has to be replaced, the gauge of the wires in the new cable must be at least 0.75 mm^2 (3 x 0.75 cable), bearing in mind that the earth wire (yellow-green) must be at least 20 mm longer at the end for connection to the appliance. Use only a type H05V2V2-F or similar cable resistant to a temperature of up to 90°C . The cable must be replaced by a qualified electrician, who must make the mains connection as shown below.

L = brown

N = blue

 = yellow-green

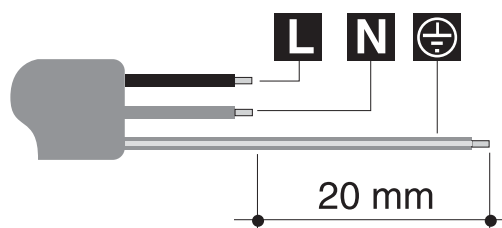

The power supply lead must be replaced by an authorised service centre to prevent all risks.



The manufacturer declines all responsibility for injury or damage caused by failure to comply with the above regulations or deriving from tampering with even just one part of the appliance.



Instructions for the Installer

4. Gas connection

If the appliance is installed above an oven, the gas hose must be passed around the back of the oven to prevent overheating.

The connection to the gas mains may be made using a copper pipe or a continuous-wall steel hose in accordance with the relevant regulations. To simplify connection, the horizontal position of the fitting **A** on the back of the appliance is adjustable. Undo the hexagonal nut **B**, turn the fitting **A** into the required position and re-tighten the hexagonal nut **B** (it has a rubber gasket to ensure it provides an effective seal). When installation is complete, check for any leaks with a soapy solution, never with a naked light. The hob is tested with G20 (2H) natural gas at the pressure of 20 mbar. For use with other types of gas, see point "5. ADAPTING TO DIFFERENT TYPES OF GAS". The gas intake connection has an external 1/2" gas thread (ISO 228-1).

Connection with copper pipe: The connection to the gas supply mains must be made so that no stresses or strains of any kind are applied to the appliance. The connection can be made using the adapter unit **D** with two conical elements, always fitting the gasket **C** supplied.

Connection with steel hose: use only continuous-wall stainless steel hoses compliant with the relevant regulations, and always fit the gasket **C** supplied between the fitting **A** and the hose **E**.

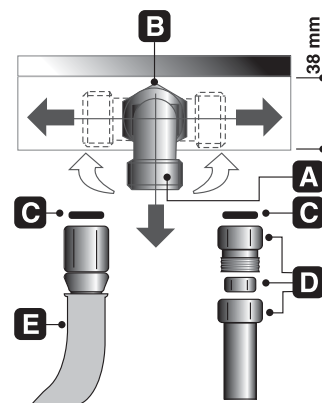

When connecting with a hose, ensure that the total length of the pipeline is not more than 1.5 metres; also ensure that the hoses do not touch moving parts and are not crushed.



4.1 Bottled gas connection



Use a pressure regulator and make the connection to the gas cylinder in accordance with the relevant regulations. Make sure that the gas supply pressure is as stated in the table in point "5.2 Adjusting for bottled gas".

4.2 Room ventilation



The appliance may only be installed in a permanently ventilated room as specified by the relevant regulations. The air flow into the room where the appliance is installed must be sufficient for proper gas combustion and room ventilation. The air intakes, protected by gratings, must be of suitable size (see relevant regulations) and located so that they cannot be even partially obstructed.

The kitchen must be kept properly ventilated to disperse the heat and humidity produced by cooking processes: in particular, a window should be opened or the speed of any fans increased after prolonged use.

4.3 Combustion gas discharge



Combustion gases may be discharged by means of hoods connected to a flue with reliable natural draught, or a fan extraction system. An effective extraction system requires careful design by an authorised specialist, and must comply with the regulation distances and positions. After installation, the engineer must issue a certificate of compliance.



Instructions for the Installer

5. Adapting to different types of gas



Before carrying out the operations described below, disconnect the appliance from the electricity supply.

The hob is tested with **G20 (2H) natural gas** at the pressure of 20 mbar.

If it is to be used with other types of gas, the burner nozzles have to be changed and the primary air flow adjusted.

To replace the nozzles and adjust the burners, the hob plate has to be removed as described below.

5.1 Removing the hob skin

Remove all the burner components in the numerical order shown below:

- Remove the pan stands (Fig.1) by lifting them at the back (1) and extracting them (2). (On 70 cm hobs remove the central pan stand first; on 60 cm hobs the right-hand pan stand must be removed first);
- remove all the knobs (3, Fig.2) by pulling them outward;
- lift all the burner components off the hob (4-5, Fig. 2);
- use the spanner 6 (Fig. 3) to open the bayonet fastenings of the burner fixing rings, applying leverage on the guides 7;
- after removing all the components described above, lift the front of the hob skin (8, Fig. 4).
- the burners and gas taps can only be accessed by pushing the rear of the hob gently upwards with the aid of a tool (9-10, Fig. 5).

This is necessary to release the internal snap fixing devices. The hob skin can now be removed. Some models may have 2 additional pins at the side (Fig. 5), which must be removed in the same way, using a tool to apply leverage to the hob.

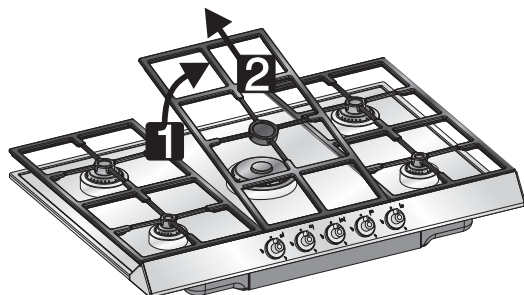

Fig 1)

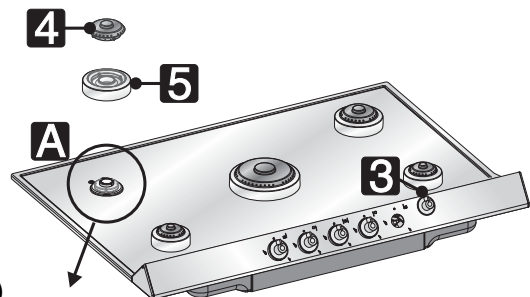

Fig 2)

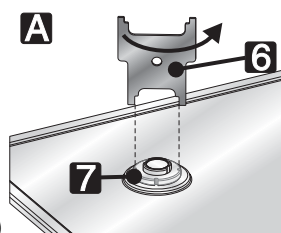

Fig 3)

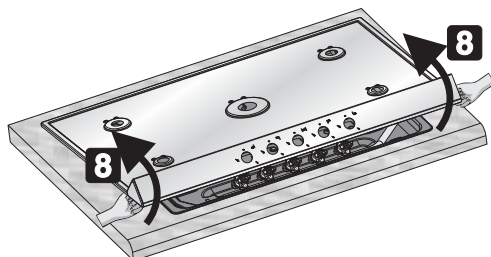

Fig 4)

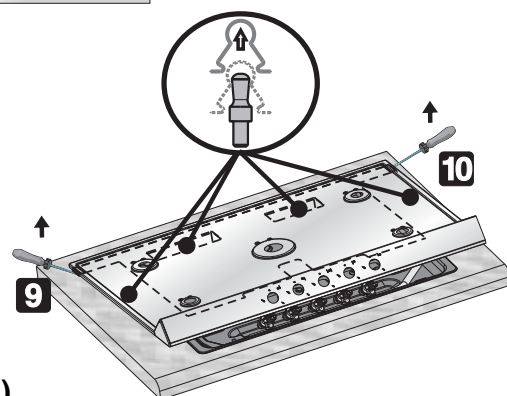

Fig 5)



5.2 Adjusting for bottled gas

Undo the screw **A** and push the support **B** fully down. Remove the nozzle **C** with a spanner and fit the suitable one following the instructions in the tables referring to the type of gas to be used. The nozzle must not be tightened with a torque of more than **3 Nm**. Return the support **B** to its original position, so that the nozzle **C** is perfectly covered.

Regulate the air flow by moving the Venturi pipe **D** until the distance "**X**" stated in point "5.5 Adjusting the primary air flow" is obtained and secure it with the screw **A**. When the adjustments are complete, restore the seals with wax or an equivalent material.

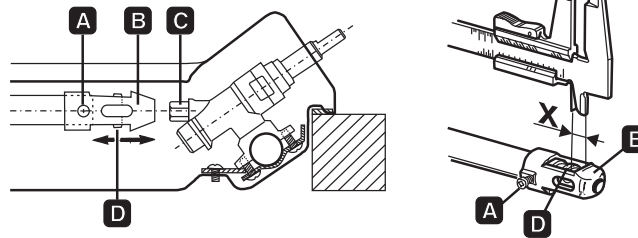

Burner	Nominal heat capacity (kW)	Bottled gas – G30/G31 30/37 mbar					
		Nozzle diameter 1/100 mm	By-pass mm 1/100	Reduced heat capacity (W)	Capacity g/h G30	Capacity g/h G31	
Auxiliary	1.05	48	30	400	76	75	
Semi rapid	1.7	62	33	500	124	121	
Rapid (3)	3.5	89	50	1050	254	250	
Rapid (7)	2.9	80	50	1050	211	207	
Rapid (6)	3.1	85	50	1050	225	221	
Ultra-Rapid	4.2	98	65	1600	305	300	
Double Crown (4)	Internal	0.9	45	30	400	62	61
	External	3.3	87	55	1200	240	236
Double Crown (8)	Internal	0.9	45	30	400	62	61
	External	4.0	95	55	1200	291	286

5.3 Adjusting for town gas

To allow the unit to work with this type of gas, perform the same operations described in paragraph "5.2 Adjusting for bottle gas", but choose the nozzles and regulate the primary air for town gas, as shown in the following table and in paragraph "5.5 Adjusting the primary air flow".

Burner	Nominal heat capacity (kW)	Town gas – G110 8 mbar	
		Nozzle diameter 1/100 mm	Reduced heat capacity (W)
Auxiliary	1.05	132	400
Semi rapid	1.7	165	500
Rapid (3)	3.5	250	900
Rapid (7)	2.9	230	1.05
Rapid (6)	3.1	240	900
Ultra-Rapid	4.2	300	1100
Double Crown (4)	Internal	0.9	400
	External	3.3	1200
Double Crown (8)	Internal	0.9	400
	External	4.0	1200



Instructions for the Installer

5.4 Adjusting for natural gas

The appliance is tested with **G20 (2H) natural gas** at the pressure of 20 mbar. To return the appliance to the condition required to use this type of gas, proceed as described in point “5.2 Adjusting for bottled gas” but select the nozzles and adjust the primary air flow for natural gas, as indicated in the table below and in point “5.5 Adjusting the primary air flow”.

Burner	Nominal heat capacity (kW)	Natural gas – G20 20 mbar	
		Nozzle diameter 1/100 mm	Reduced heat capacity (W)
Auxiliary	1.05	132	400
Semi rapid	1.7	165	500
Rapid (3)	3.5	250	900
Rapid (7)	2.9	230	1.05
Rapid (6)	3.1	240	900
Ultra-Rapid	4.2	300	1100
Double Crown (4)	Internal	0.9	126
	External	3.3	250
Double Crown (8)	Internal	0.9	126
	External	4.0	140

5.5 Adjusting the primary air flow

Refers to the gap “X” in mm.

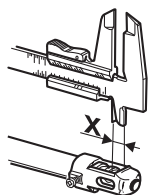

BURNER	G20 20 mbar	G30/G31 30/37 mbar	G110 8 mbar
Auxiliary	2.0	10.0	1.0
Semi rapid	2.0	10.0	1.5
Rapid (3)	2.5	8.0	2.0
Rapid (7)	2.5	8.0	1.5
Rapid (6)	2.5	10.0	1.0
Ultra-Rapido	2.5	12.0	5.0
Double Crown (4)	Internal	5.0	5.0
	External	10.0	10.0
Double Crown (8)	Internal	5.0	5.0
	External	13.0	13.0

To identify the burners on your hob, refer to the drawings in point “5.8 Hob burner layout”

5.6 Reassembling the hob skin

Reverse the procedure described in point “5.1 Removing the hob skin”.



When replacing the burner rings, bear in mind that they must be **fully tightened** using the spanner provided.

Put the pan stands back in place, fitting first those at the side and then the central one.



5.7 Adjusting the minimum setting for natural gas and town gas

Reassemble the components on the burner and fit the knobs onto the tap rods.

Light the burner and turn it to the minimum setting. Remove the knob again and adjust the regulator screw inside or beside the tap rod (depending on the model) until an even minimum flame is obtained. Put the knob back in place and check the stability of the burner flame (the flame must not go out when the knob is turned quickly from the maximum to the minimum setting).

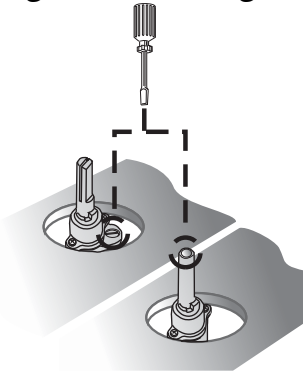

5.8 Adjusting the minimum for bottled gas

To adjust the minimum level when using bottled gas, the adjuster screw inside or beside the tap rod must be turned fully clockwise (depending on the models). The diameters of the bypasses for each individual burner are stated in point "5.2 Adjusting for bottled gas".



After adjusting for use of a gas other than the gas used for testing the appliance, replace the label on the casing with the label for the new gas. The label is supplied in the bag with the LPG nozzles (G30 ^ G31).

5.9 Hob burner layout

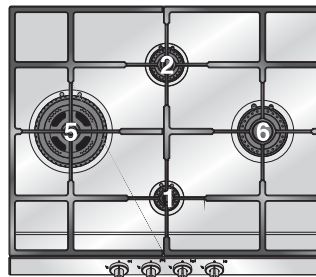
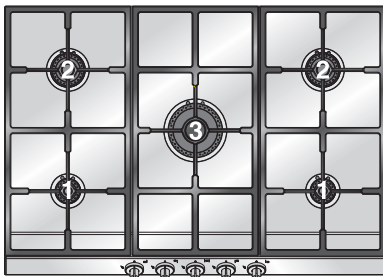

Burner type

- 1 Auxiliary
- 2 Semi rapid
- 3 Rapid
- 4 Double flame
- 5 Ultra rapid
- 6 Rapid
- 7 Rapid
- 8 Double flame

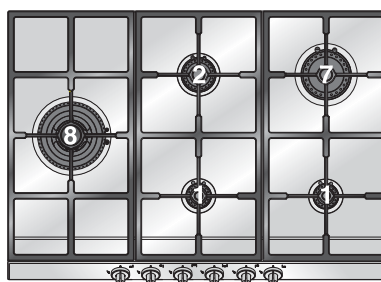
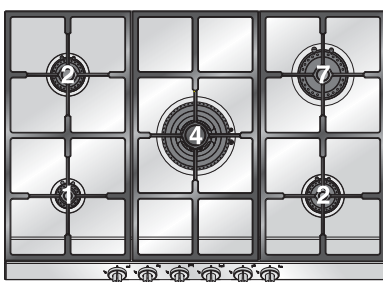

5.10 Greasing the gas taps

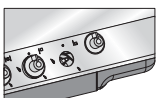

Over time, the gas taps may become stiff or jam. Clean their insides and change their lubricating grease. **This operation must be carried out by a skilled technician.**



Instructions for the User

6. Description of controls

6.1 The front panel

All the hob's control and monitoring devices are placed together on the front panel.

MODEL 60 CONTROL PANEL

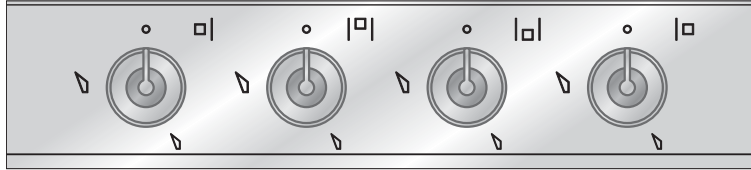

4 Burner Hob

MODEL 70 CONTROL PANEL

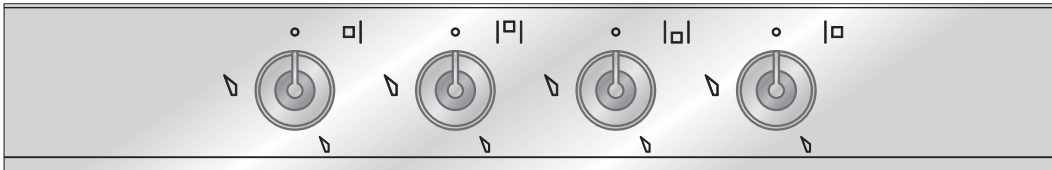

4 Burner Hob

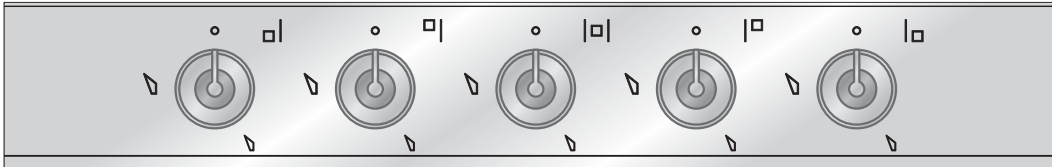

5 Burner Hob

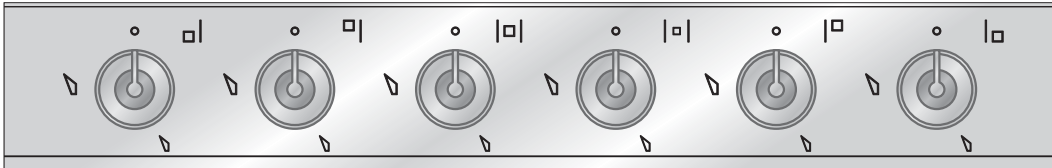

6 Burner Hob, UR2 in Centre

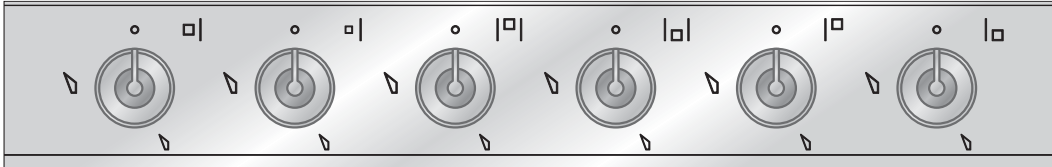

6 Burner Hob, UR2 at Side

KNOB OPERATING MODE

To light the flame, press the knob and at the same time turn it anti-clockwise to the minimum flame symbol.

To adjust the flame, turn the knob to the zone between the maximum and the minimum settings.

To turn off the burner, turn the knob back to the O position.

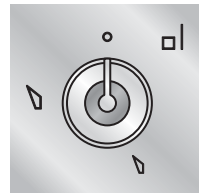

BURNER LAYOUT - Key to symbols

	Front left-hand burner		Front central burner		Front right-hand burner
	Left-hand central burner / Outside left-hand central burner		Central burner / Outside central burner		Right-hand central burner
	Inside left-hand central burner		Inside central burner		Rear right-hand burner
	Rear left-hand burner		Rear central burner		



7. Using the hob



Check that the fixing rings, burners, flame diffuser rings and pan stands are fitted correctly.

The burner pins **A** must be fitted into the recesses **B** in the flame diffuser ring. The holes **C** in the flame diffuser ring must mate with the ignition plugs and thermocouples **D** on the hob.

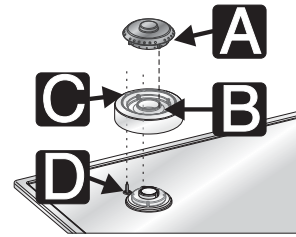

7.1 Lighting burners with safety device



The burner it controls is shown next to each knob (the example here shows the front left-hand burner).

The appliance is equipped with electronic ignition. Simply press the knob and turn it anti-clockwise to the minimum flame symbol , until the burner lights. Keep the knob pressed down for about 2 seconds to keep the flame alight and prime the safety device. The burner may go out when the knob is released. In this case, repeat the operation, keeping the knob pressed down for longer.



If the burners should go out accidentally the safety device will be tripped about 20 seconds later, cutting off the gas supply even if the gas tap is open.

7.2 Positioning the griddle plate

A special griddle plate for use with the hob is available from authorised dealers. This plate must be placed on the pan stands properly CENTRED; it must never be fitted instead of a pan stand.

Ensure that the griddle plate is properly centred on the pan stand; if it is not correctly positioned, the knobs may overheat while it is in use.

7.3 Practical hints for using the burners

For better burner efficiency and to minimise gas consumption, use flat, even-bottomed pans with lids of suitable size for the burner (see point "7.3 Pan Diameters").

When cooking, to prevent burns or damage to the hob all pans or griddle plates must be placed inside the perimeter of the hob and must be at least **3-4 cm** from the knobs.





Instructions for the User

7.4 Pan diameters

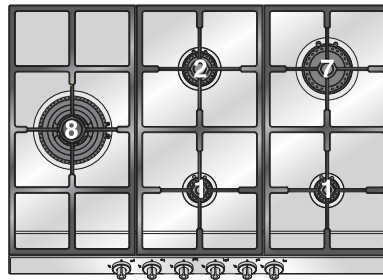
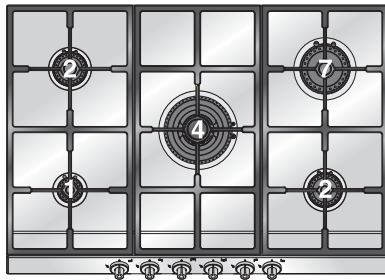
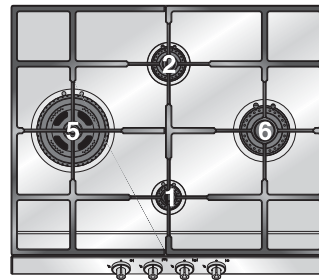
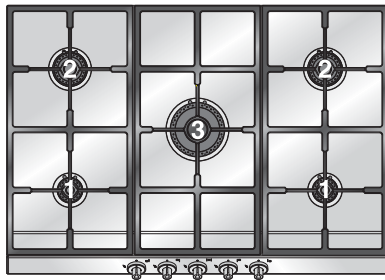
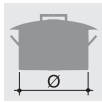

BURNERS

min. and max. Ø (in cm)

1 Auxiliary	7-18
2 Semi rapid	10-24
3 Rapid	18-24
4 Double flame	12-28
5 Ultra rapid	20-28
6 Rapid	18-24
7 Rapid	18-24
8 Double flame	12-30



8. Cleaning and maintenance



Before carrying out any operations, disconnect the appliance from the electricity supply.

8.1 Cleaning stainless steel



To keep the hob in good condition, it must be cleaned regularly, after each use, first allowing it to cool.

8.1.1 Routine daily hob cleaning

When cleaning and caring for stainless steel surfaces, always use **only** specific products which do not contain abrasives or chlorine-based acids.

Instructions for use: pour the product onto a damp cloth and wipe over the surface, then rinse thoroughly and dry with a soft cloth or chamois leather.

8.1.2 Food stains or spills

Never use metal scouring pads or sharp scrapers which will damage the surface.

Use ordinary non-abrasive products for steel, with the aid of non-scratching sponges and wooden or plastic utensils if necessary.

Rinse thoroughly and dry with a soft cloth or chamois leather.



8.2 Cleaning the components



8.2.1 The knobs

The knobs and front panel must be cleaned with a soft cloth dipped in warm water and dried thoroughly. The knobs can easily be removed by pulling them outwards.



Never clean the knobs or front panel with aggressive products containing alcohol or steel or glass cleaners, since they might cause permanent damage.

8.2.2 Pan stands and burners



Remove the pan stands and wash them in warm water with a non-abrasive detergent, taking care to remove all deposits. Put them back on the hob. These components must never be washed in a dishwasher.

8.2.3 The flame diffuser rings

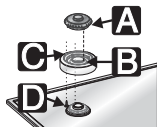

The burner caps and flame diffuser rings can be removed for easier cleaning; wash them in hot water and non-abrasive detergent, taking care to remove all deposits, and wait for them to **dry completely**.

The burner pins **A** must be fitted into the recesses **B** in the flame diffuser ring. The holes **C** in the flame diffuser ring must mate with the ignition plugs and thermocouples **D** on the hob.

NEVER REMOVE THE FIXING RINGS TO CLEAN THE HOB.

8.2.4 The plugs and thermocouples

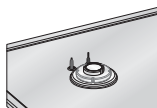

For best performance, the ignition plugs and thermocouples must always be kept thoroughly clean. Check them frequently and if necessary clean them with a wet cloth. Remove any dry residues with a wooden toothpick or a needle.