



SILVERSTONE

Flex ATX SERIES FX600 Platinum

Cybenetics Platinum 600W Flex ATX power supply

Support standard Flex ATX form factor
High efficiency with Cybenetics Platinum certification
600W continuous power output at 40°C operating temperature rated for 24/7 operation
Japanese primary capacitor
Class-leading single +12V rail
PCIe 8pin and PCIe 6pin connectors support
Active PFC

SPECIFICATION

SilverStone Flax ATX Series

FX600 Platinum

SST-FX600-PT

Switching Power Supply Cybernetics Platinum efficiency certified. 600W

This specification describes the requirements of 600W with full range voltage, switching power supply with Flex-ATX form-factor and, +5V standby voltage, remote on/off .

1.0 INPUT:

1.1 AC input requirements

The input voltage, current, and frequency requirements for continuous operation are stated below.

Table 1 AC Input Line Requirements

Parameter	Min	Nom	Max	Unit
Vin	90	100-240	264	VACrms
Vin Frequency	47	60----50	63	Hz
Iin(600W)		8-----4		

Power factor correction (PF)>0.9 at full load.

1.2 Inrush current regulation

The power supply must meet inrush requirements for any rated AC voltage, during turn on at any phase of AC voltage, during a single cycle AC dropout condition, during repetitive ON/OFF cycling of AC, and over the specified temperature range (Top).

The peak inrush current shall be less than the ratings of its critical components (including input fuse, bulk rectifiers, and surge limiting device).

2.0 DC OUTPUT :

2.1 DC voltage regulation

Parameter	Range	Min	Nom.	Max	Unit
+3.3V	±5%	+3.14	+3.3	+3.47	Volts
+5V	±5%	+4.75	+5.0	+5.25	Volts
+12V	±5%	+11.4	+12.0	+12.6	Volts
-12V	±10%	-10.8	-12.0	-13.2	Volts
+5Vsb	±5%	+4.75	+5.0	+5.25	Volts

2.2 600W Load range

Parameter	Min	Nom.	Max	Peak	Unit
+3.3V	0.1	-	15		Amps
+5V	0.2	-	15		Amps
+12V	0.5	-	50		Amps
-12V	0A	-	0.3		Amps
+5Vsb	0A	-	2.5		Amps

Notes:

- (1) The maximum combined load on +3.3V and +5V outputs shall not exceed 80W.
- (2) The +12V maximum load shall not exceed 600W.
- (3) The maximum continuous average DC outputs power shall not exceed 600W.

2.3 Output Ripple

2.3.1 Ripple regulation

Parameter	Ripple& Noise	Unit
+3.3V	50	mVp-p
+5V	50	mVp-p
+12V	120	mVp-p
-12V	120	mVp-p
+5Vsb	50	mVp-p

2.3.2 Definition

The ripple voltage of the outputs shall be measured at the pins of the output connector when terminated in the load impedance specified in figure1. Ripple and noise are measured at the connectors with a 0.1uF ceramic capacitor and a 10uF electrolytic capacitor to simulate system loading. Ripple shall be measured under any condition of line voltage, output load, line frequency, operation temperature.

2.3.3 Ripple voltage test circuit

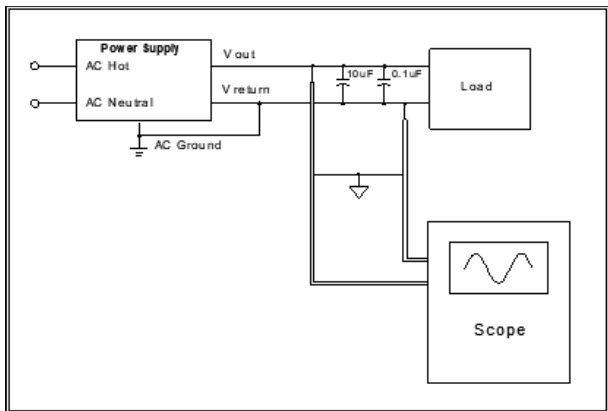

Figure 1. Ripple voltage test circuit

2.4 Overshoot

Any overshoot at turn on or turn off shall be less 10% of the nominal voltage value, all outputs shall be within the regulation limit of section 2.0 before issuing the power good signal of section 5.0.

2.5 Efficiency

At 115Vac

load	Efficiency
10%	
20%	90%
50%	92%
100%	89%

2.6 Remote on/off control

When the logic level "PS-ON" is low, the DC outputs are to be enabled.
When the logic level is high or open collector, the DC outputs are to be disabled.

3.0 PROTECTION

3.1 Over current protection

The power supply shall have current limit to prevent the +3.3V,+5V,and +12V outputs from exceeding the values shown in the following Table. If the current limits are exceeded the power supply shall shutdown and latch off.

Voltage	Over Current Limit (Iout limit)
+12V	52A minimum; 70A maximum
+5V	18A minimum; 30A maximum
+3.3V	18A minimum; 30A maximum

3.2 Over Temperature Protection

The power supply will be protected against over temperature conditions caused by loss of fan cooling or excessive ambient temperature. In an OTP condition the PSU will shutdown. When the power supply temperature drops to within specific limits, the power supply shall restore power automatically. The OTP must have built in hysteresis such that the power supply will not oscillate on and off due to circuit temperature recovering condition.

3.3 Over-power protection

The power supply will be shutdown and latch off when output power within 110~130% of rated DC output.

Note: Assurance machine can work at low voltage,full load won't damage machine.

3.4 Under voltage protection.

In an under voltage fault occurs, the supply will latch all DC outputs into a shutdown state when +12V,+5V & +3.3V outputs under 85% of it's maximum value.

3.5 Over voltage protection

The over voltage sense circuitry and reference shall reside in packages that are separate and distinct from the regulator control circuitry and reference. No single point fault shall be able to cause a sustained over voltage condition on any or all outputs. The supply shall provide latch-mode over voltage protection as defined in Table.

Output	Minimum	Nominal	Maximum	Unit
+12V VDC	13	15	17	Volts
+5 VDC	5.5	6	7	Volts
+3.3 VDC	3.6	4	5	Volts

3.6 Short circuit protection

An output short circuit is defined as any output impedance of less than 0.1 ohms. The power supply shall shut down and latch off for shorting the +3.3 VDC, +5 VDC, or +12VDC rails to return or any other rail. Shorts between main output rails and +5VSB shall not cause any damage to the power supply.

The power supply shall either shut down and latch off or fold back for shorting the negative rails. +5VSB must be capable of being shorted indefinitely, but when the short is removed, the power supply shall recover automatically or by cycling PS_ON#. The power supply shall be capable of withstanding a continuous short-circuit to the output without damage or overstress to the unit

3.7 No load operation

No damage or hazardous condition should occur with all the DC output connectors disconnected from the load. The power supply may latch into the shutdown state.

4.0 TIMING

4.1 Signal timing drawing

Figure 2 is a reference for signal timing for main power connector signals and rails.

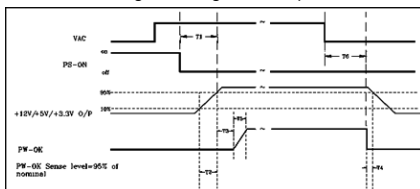

- (1)T3: Power good signal turn on delay time (100ms~500ms)
- (2)T4: Power good signal turn off delay time (75%Load 1ms min)
- (3)T2: Rise time (0.1~20ms)
- (4)T6: Hold up time (75%Load 16ms Min)

4.2 Hold up time

When the power loss its input power, it shall maintain 16ms in regulation limit at normal input voltage and 75% load (AC:115V/60Hz or 230V/50Hz)

5.0 ENVIRONMENT

5.1 Operation

Temperature	0 to 40 °C
Relative Humidity	to 85%, on-condensing

5.2 Shipping and Storage

Temperature	-20 to 90°C
Relative Humidity	to 95%,non-condensing

5.3 Altitude

Operating	2000m
Storage	3000m

6.0 SAFETY

6.1 Underwriters Laboratory (UL) recognition.

The power supply designed to meet UL 60950/62368.

7.0 ELECTROMAGNETIC COMPATIBILITY (EMC)

8.0 MTBF

8.1 MTBF (mean time between failures) calculation

The demonstrated MTBF shall be 100,000 hours of continuous operation at 25°C, full load and 120V AC input. The MTBF of the power supply shall be calculated in accordance with MIL-HDBK-217F. The DC FAN is not included.

9.0 MECHANICAL REQUIREMENTS

9.1 Physical dimension : L150mm*W82mm*H40.5mm

10.0. POWER SUPPLY CONNECTOR OVERUSE DEFINITION

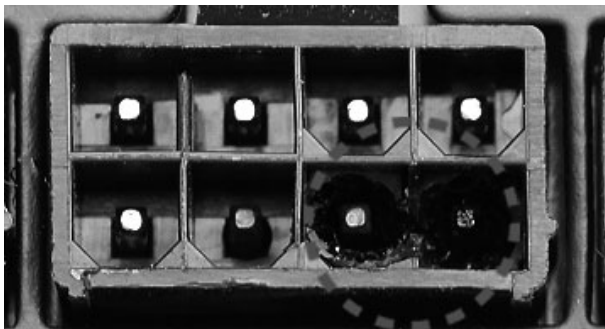

EN Power supply connector overuse definition

A single PCIe 8pin cable and connector's maximum current rating is 12.5A, which is 150W (+12V x 12.5A). So SilverStone's warranty will not cover damages or malfunction resulting from the use of a graphics card or expansion card with a single PCIe 8pin connector that exceeds standard 225W total power draw (150W from PCIe 8pin connector + 75W from PCIe motherboard slot). Similarly, a graphics card or expansion card with dual PCIe 8pin connectors that exceed 375W total power draw (300W from two PCIe 8pin connectors + 75W from PCIe motherboard slot) will also not be covered under warranty.

Peripheral (molex) or SATA connector's maximum current rating is 5A, which is 60W (+12V x 5A) or 25W (+5V x 5A). Please ensure connected devices are operating under these limits. SilverStone's warranty will not cover damages or malfunction resulting from usages exceeding these connectors and their associated cables.

24pin motherboard connector's maximum current rating for its dual +12V metal pins are 5A each, which totals 120W (+12V x 5A x 2). Please ensure +12V drawing devices connected to the motherboard are operating under these limits. SilverStone's warranty will not cover damages or malfunction resulting from usages exceeding these connectors and their associated cables.

DE Definition einer Überlastung des Netzan schlusses

Die maximale Stromstärke eines einzelnen 8-poligen PCIe-Kabels und Anschlusses beträgt 12,5 A, was 150 W (+12 V x 12,5 A) entspricht. Daher deckt die SilverStone-Garantie keine Schäden oder Fehlfunktionen durch den Einsatz einer Grafikkarte oder Erweiterungskarte mit einem einzigen 8-poligen PCIe-Anschluss ab, die die Standardleistungsaufnahme von insgesamt 225 W übersteigt (150 W vom 8-poligen PCIe-Anschluss + 75 W vom PCIe-Motherboard-Steckplatz). Ebenso wird die Verwendung einer Grafikkarte oder Erweiterungskarte mit zwei 8-poligen PCIe-Anschlüssen, die eine Leistungsaufnahme von insgesamt 375 W übersteigen (300 W von den beiden 8-poligen PCIe-Anschlüssen + 75 W vom PCIe-Motherboard-Steckplatz) nicht durch die Garantie abgedeckt.

Der maximale Nennstrom von Peripherie- (Molex) oder SATA-Anschluss beträgt 5 A, was 60 W (+12 V x 5 A) oder 25 W (+5 V x 5 A) entspricht. Bitte achten Sie darauf, dass verbundene Geräte unter diesen Grenzwerten arbeiten. Die Garantie von SilverStone deckt keine Schäden oder Fehlfunktionen aufgrund einer Nutzung ab, die diese Anschlüsse und ihre zugehörigen Kabel übersteigt.

Der maximale Nennstrom des 24-poligen Motherboard-Anschlusses für seine dualen +12-V-Metallkontakte beträgt jeweils 5 A, was insgesamt 120 W (+12 V x 5 A x 2) ergibt. Bitte stellen Sie sicher, dass mit dem Motherboard verbundene +12-V-Geräte unter diesen Grenzwerten arbeiten. SilverStones Garantie deckt keine Schäden oder Fehlfunktionen aufgrund einer Nutzung jenseits der Angaben dieser Anschlüsse und ihrer zugehörigen Kabel ab.

FR Définition de l'utilisation excessive du connecteur d'alimentation électrique

Le courant nominal maximum d'un câble et d'un connecteur PCIe 8 broches unique est de 12,5 A, ce qui correspond à 150 W (+12 V x 12,5 A). La garantie de SilverStone ne couvre donc pas les dommages ou les dysfonctionnements résultant de l'utilisation d'une carte graphique ou d'une carte d'extension avec un connecteur PCIe 8 broches unique qui dépasse une consommation énergétique totale de 225 W standard (150 W provenant du connecteur PCIe 8 broches + 75 W provenant de l'emplacement de la carte mère PCIe). De même, une carte graphique ou une carte d'extension avec deux connecteurs PCIe 8 broches qui dépasse une consommation énergétique totale de 375 W (300 W provenant des deux connecteurs PCIe 8 broches + 75 W provenant de l'emplacement de la carte mère PCIe) ne sera également pas couverte dans le cadre de la garantie.

Le courant nominal maximum d'un périphérique (Molex) ou d'un connecteur SATA est de 5 A, ce qui correspond à 60 W (+12 V x 5 A) ou 25 W (+5 V x 5 A). Veuillez vous assurer que les appareils connectés fonctionnent dans ces limites. La garantie de SilverStone ne couvre pas les dommages ou les dysfonctionnements résultant d'utilisations dépassant ces connecteurs et leurs câbles associés.

Le courant nominal maximal des connecteurs 24 broches de la carte mère pour ses doubles broches métalliques +12 V est de 5 A chacun, ce qui représente au total 120 W (+12 V x 5 A x 2). Veuillez vous assurer que les dispositifs de tension +12 V connectés à la carte mère fonctionnent dans ces limites. La garantie de SilverStone ne couvre pas les dommages ou les dysfonctionnements résultant d'utilisations dépassant la capacité de ces connecteurs et de leurs câbles associés.

IT Definizione di uso eccessivo del connettore di alimentazione

La corrente massima di un singolo cavo PCIe a 8 pin e del connettore è 12,5 A, corrispondente a 150 W (+12 V x 12,5 A). Pertanto, la garanzia di SilverStone non copre danni o malfunzionamenti derivanti dall'utilizzo di una scheda grafica o una scheda di espansione con un singolo connettore PCIe a 8 pin che supera l'assorbimento totale di 225 W (150 W da connettore PCIe a 8 pin + 75 W da slot PCIe). Analogamente, la garanzia non copre anche una scheda grafica o una scheda di espansione con doppi connettori PCIe a 8 pin che superano l'assorbimento totale di 375 W (300 W da doppi connettori PCIe a 8 pin + 75 W dalla scheda madre PCIe).

La corrente massima del connettore periferico (molex) o SATA è 5 A, corrispondente a 60 W (+12 V x 5 A) o 25 W (+5 V x 5 A). Assicurarsi che i dispositivi collegati funzionino entro questi limiti. La garanzia di SilverStone non copre danni o malfunzionamenti derivanti da uso eccessivo di questi connettori e dei relativi cavi.

La corrente massima del connettore a 24 pin per scheda madre per i suoi due pin di metallo a +12 V è di 5 A ciascuno, per un totale di 120 W (+12 V x 5 A x 2). Assicurarsi che i dispositivi a +12 V collegati alla scheda madre funzionino con questi limiti. La garanzia di SilverStone non copre danni o malfunzionamenti derivanti da uso eccessivo di questi connettori e dei relativi cavi.

ES Definición de uso excesivo del conector de la Fuente de alimentación

La corriente máxima de un solo cable PCIe de 8 pines es 12,5A, lo que son 150W (+12V x 12,5A). Por tanto, la garantía de SilverStone no cubrirá daños o fallos provocados por el uso de una tarjeta gráfica o de expansión con un único conector PCIe de 8 pines que exceda el total estándar de 225W (150W del conector PCIe de 8 pines + 75W del zócalo PCIe de la placa base). De igual modo, una tarjeta gráfica o de expansión con conectores duales PCIe de 8 pines que superen 375W de potencia (300W de los dos conectores PCIe de 8 pines + 75W del zócalo de la placa base) tampoco será cubierta por la garantía.

La corriente máxima del conector de periféricos (molex) o SATA es 5A, que son 60W (+12V x 5A) o 25W (+5V x 5A). Por favor, asegúrese de que los dispositivos conectados funcionan dentro de estos límites. La garantía de SilverStone no cubrirá daños o fallos a resultados de un uso excesivo de estos conectores y sus cables asociados.

La corriente máxima del conector de 24 pines de la placa base para sus pines de metal duales de +12V es de 5A cada uno, para un total de 120W (+12V x 5A x 2). Por favor, asegúrese de que los dispositivos de +12V conectados a la placa base funcionan dentro de estos límites. La garantía de SilverStone no cubrirá daños o averías a resultados de un uso excesivo para estos conectores y sus cables asociados.

RU

Определение чрезмерной нагрузки на коннектор блока питания

Один кабель и коннектор PCIe 8pin поддерживает ток 12.5A, что равно 150Вт (+12В x 12.5А). Таким образом, гарантийные обязательства SilverStone не будут действовать если вы используете видеокарту или другую карту расширения с одним коннектором PCIe 8pin, которые превышают стандартную общую потребляемую мощность 225Вт (150Вт через коннектор PCIe 8pin + 75Вт через слот PCIe материнской платы). Аналогично, видеокарта или другая карта расширения с двумя коннекторами PCIe 8pin, которые превышают общую потребляемую мощность 375Вт (300Вт через коннектор PCIe 8pin + 75Вт через слот PCIe материнской платы), также не будут покрываться гарантией.

Максимальный номинальный ток периферийного (molex) или SATA разъёма составляет 5А, что равно 60Вт (+12В x 5А) или 25Вт (+5В x 5А). Пожалуйста, убедитесь, что подключённые устройства работают в этих пределах. Гарантия SilverStone не будет распространяться на неисправности, возникающие в результате использования этих коннекторов или подключаемых к ним кабелей.

Максимальный номинальный ток 24pin коннектора материнской платы для его двойных металлических контактов +12В составляет 5А на каждый, что равно 120Вт (+12В x 5А x 2). Пожалуйста, убедитесь, что устройства, подключаемые к линии +12В, работают в этих пределах. Гарантия SilverStone не будет распространяться на неисправности, возникающие в результате использования этих коннекторов или подключаемых к ним кабелей.

KR

전원 공급 커넥터 과용 정의

단일한 PCIe 8핀 케이블 및 커넥터의 최대 전류 정격은 12.5A로서 전적으로 한산하면 150W(+12V x 12.5A)입니다. SilverStone의 보증에서는 표준 225W의 총 소비 전력 (PCIe 8핀 커넥터의 150W와 PCIe 메인보드 슬롯의 75W의 합)을 초과하는 단일 PCIe 8핀 커넥터 탑재 그래픽 카드나 확장 카드를 사용하여 발생하는 손상 또는 오작동을 보상이 않습니다. 이와 마찬가지로 375W의 총 소비 전력(PCIe 8핀 커넥터 2개의 300W와 PCIe 메인보드 슬롯의 75W의 합)을 초과하는 듀얼 PCIe 8핀 커넥터 탑재 그래픽 카드나 확장 카드를 사용해도 보증에서 보상해주지 않습니다.

주변장치(molex) 또는 SATA 커넥터의 최대 전류 정격은 5A로서 전적으로 한산하면 60W(+12V x 5A) 또는 25W(+5V x 5A)입니다. 연결된 장치들은 이러한 제한 하에서만 작동시켜야 합니다. SilverStone의 보증에서는 이러한 커넥터 및 이와 연결되는 케이블의 정격을 초과하여 사용함으로써 발생하는 손상이나 오작동을 보상이 않습니다.

듀얼 +12V 금속 핀에 사용되는 24핀 메인보드 커넥터의 정격 전류는 5A이며, 각각 함께가 120W(+12V x 5A x 2)입니다. 메인보드에서 연결된 +12V 전지가 해당 한계 미만으로 작동되도록 하십시오. SilverStone은 이 커넥터나 관련 케이블의 한계를 초과해서 사용함으로써 발생하는 손상이나 고장에 대해서 보상하지 않습니다.

JP

電力供給コネクタの使用限度超過に関する説明

単一のPCIe 8ピンケーブルおよびコネクタの最大定格電流は12.5Aで150W(+12V x 12.5A)となります。それで定格225W合計電力消費(PCIe 8ピンコネクタからの150W + PCIeマザーボードスロットからの75W)を超える。単一PCIe 8ピンコネクタ装備のグラフィックスカードまたは拡張カード使用によって生じた損傷や故障の場合、SilverStoneの製品保証は適用外となります。同様に、375W合計電力消費(2基のPCIe 8ピンコネクタからの300W + PCIeマザーボードスロットからの75W)を超える。デュアルPCIe 8ピンコネクタ装備のグラフィックスカードまたは拡張カード使用によって生じた損傷や故障の場合も、製品保証適用外となります。

周辺用 (molex) または SATA コネクタの最大定格電流は5Aで、60W (+12V x 5A) または 25W (+5V x 5A) となります。接続された装置がこれら限度以内で動作することを確認してください。これらコネクタおよび関連ケーブルの定格を超える使用法で生じた損傷や故障については、SilverStone製品保証対象外となりますのでご注意ください。

24ピンマザーボードコネクタのデュアル+12V金属製ピンに対する最大定格電流はそれぞれ5Aなので合計は120W(+12V x 5A x 2)となります。接続される+12V入力のデバイスが、これら上限以内で動作することをご確認ください。これらコネクタおよび関連ケーブルでの限界を超えた使用で生じた損傷または故障は、SilverStoneによる製品保証対象外となります。

CN

电源供应器接头过度使用定义

单条PCIe 8pin电源线与接头的最大额定电流为12.5A, 瓦特数150W (+12V x 12.5A)。因此, 银欣的电源保固不包括用于单条PCIe 8pin接头的显卡/扩充卡, 在超过标准225W总功耗范围所造成的损坏或故障 (150W的PCIe 8pin接头+75W的主板PCIe插槽)。以此类推, 若具备双PCIe 8pin接头的显卡/扩充卡, 负载一但超过375W总功耗, 视同不属于保固范围内 (300W来自两个PCIe 8pin接头+75W的主板PCIe插槽)。

大4pin (molex) 或SATA接头的最大额定电流为5A, 即60W (+12V x 5A) 或25W (+5V x 5A)。请确保连接的设备皆低于此限制下运行。

银欣不保固超出电源供应器接头及其相关线材之使用负载上限所造成的损坏或故障。

24pin主板接头的双+12V金属引脚最大额定电流为5A, 即120W (+12V x 5A x 2)。请确保连接的+12V设备皆低于此限制下运行。

银欣不保固超出电源供应器接头及其相关线材之使用负载上限所造成的损坏或故障。

TW

電源供應器接頭過度使用定義

單條PCIe 8pin電源線與接頭的最大額定電流為12.5A, 瓦特數150W (+12V x 12.5A)。因此, 銀欣的電源保固不包括用於單條PCIe 8pin接頭的顯卡/擴充卡, 在超過標準225W總功耗範圍所造成的損壞或故障 (150W的PCIe 8pin接頭+75W的主機板PCIe插槽)。以此類推, 若具備雙PCIe 8pin接頭的顯卡/擴充卡, 負載一但超過375W總功耗, 視同不屬保固範圍內 (300W來自兩個PCIe 8pin接頭+75W的主機板PCIe插槽)。

大4pin (molex) 或SATA接頭的最大額定電流為5A, 即60W (+12V x 5A) 或25W (+5V x 5A)。請確保連接的設備皆低於此限制下運行。

銀欣不保固超出電源供應器接頭及其相關線材之使用負載上限所造成的損壞或故障。

24pin主機板接頭的雙+12V金屬針腳最大額定電流為5A, 即120W (+12V x 5A x 2)。請確保連接的+12V設備皆低於此限制下運行。

銀欣不保固超出電源供應器接頭及其相關線材之使用負載上限所造成的損壞或故障。

สำหรับผลิตภัณฑ์ของสายผลิตภัณฑ์ PCI-E 8 พินสามารถรองรับการใส่ไดสก์ 12.5 วัตต์หรือจานแข็ง 150 วัตต์ (+12V x 12.5A) สำหรับกรณีรับใช้จาก SilverStone ซึ่งเป็นระบบที่มีความเสถียรและมีความปลอดภัยสูงที่สุดที่มีอยู่ในตลาดการรองรับการใส่จานแข็งจากสายผลิตภัณฑ์ PCI-E 8 พิน ซึ่งมีกำลังไฟเพียง 60 วัตต์จะขึ้นอยู่กับสายที่ใช้งานได้ 225 วัตต์ (150 วัตต์ จาก PCI-E 8 พิน + 75 วัตต์ จากสาย PCI-E แบบธรรมดา) ดังนั้นการพิจารณาการใส่จานแข็งให้ผลิตภัณฑ์ PCI-E 8 พินผ่าน 2 จุดนี้คือการใส่ไดสก์ขนาดถึง 375 วัตต์ (300 วัตต์ จาก PCI-E 8 พิน 2 ชุด + 75 วัตต์ จากสาย PCI-E แบบธรรมดา) จึงไม่แนะนำเลย

การใส่จานแข็งกับ ตัวเชื่อมต่อ Peripheral หรือ Male 4 พิน SATA สามารถรองรับการใส่ไดสก์ 5 วัตต์หรือจานแข็ง 60 วัตต์ (+12V x 5A) หรือ (+5V + 3A) อย่างไรก็ตามโปรดทราบว่ามีการใส่ไดสก์ขนาดใหญ่กว่าที่รองรับได้อีกด้วย สำหรับกรณีรับใช้จาก SilverStone ซึ่งเป็นระบบที่มีความเสถียรและมีความปลอดภัยสูงที่สุดที่มีอยู่ในตลาดการใส่ไดสก์ขนาดใหญ่ให้ผลิตภัณฑ์เหล่านี้

กรณีใส่พ่วงสูงสุดของสายเชื่อมต่อ 24 พิน สำหรับพินที่ +12V (ชุดพินที่) 5A ถึงระบบระบบ 120W

(+12V x 5A x 2) ไม่แนะนำเลยให้มีการใส่พ่วงไดสก์พลังงาน +12V ที่เกินกว่าที่แนะนำตามที่กำหนด

จำกัดการใช้ การใส่สายรับเงิน SilverStone ไม่แนะนำเลยเช่นกัน กรณีการใส่ไดสก์ขนาดใหญ่ให้ผลิตภัณฑ์ของสายเชื่อมต่อเหล่านี้

1. 為了保護使用者及防火的目的，安裝此交換式電源供應器時，必須安裝於符合下列各項要求的外殼中，並且安裝妥善後，才可接上電源。
 - 1-1. 外殼材質須為防火外殼。外壳材质须为防火外壳。
 - 1-2. 外殼的上方及側邊之圓形開孔，最大內徑不可大於5mm。
 - 1-3. 外殼的上方及側邊之長條型開孔，對角線距離不可大於5mm；若寬度小於1mm，則長度不受限制。
 - 1-4. 外殼底部不可有開孔。外壳底部不可有开孔。

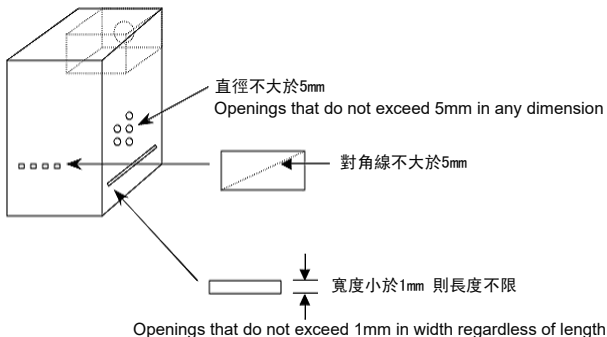

2. 本產品輸出含有危險能量，為避免操作時發生危險，須於裝入系統機殼並將所有設備安裝妥當後才可開啟電源。
3. 本產品之電源輸出非屬電力限制型電源，請連接使用具防火外殼之周邊，以避免火災危險發生。

BSMI ROHS 資訊

<http://www.silverstonetek.com/downloads/PSU/RSD.pdf>

开关电源供应器 有毒有害物质/元素及其化学含量表						
部件名称	铅 (Pb)	汞 (Hg)	镉 (Cd)	六价铬 (Cr(VI))	多溴联苯 (PBB)	多溴二苯醚 (PBDE)
外壳	○	○	○	○	○	○
接头	○	○	○	○	○	○
风扇	○	○	○	○	○	○
电子卡	○	○	○	○	○	○
线材	○	○	○	○	○	○
螺丝	○	○	○	○	○	○
包材	○	○	○	○	○	○

<p>本表格依据SJ/T 11364的规定编制</p> <p>○：表示该有毒有害物质在该部件所有均质材料中的含量均在GB/T 26572 规定的限量要求以下。</p> <p>×：表示该有毒有害物质至少在该部件的某一均质材料中的含量超出GB/T 26572 规定的限量要求。</p>	 <div style="border: 1px solid black; padding: 5px; display: inline-block;"> <p>产品合格证</p> <p>制造商: 银石 生产日期: 见产品铭牌</p> </div>
--	---

This device complies with Part 15 of the FCC Rules.

Operation is subject to the following two conditions:

- (1) this device may not cause harmful interference, and
- (2) this device must accept any interference received, including interference that may cause undesired operation.

※付属の電源コードは当該製品専用です。他の機器に使用しないでください。

Please refer to SilverStone website for latest specifications updates.

SilverStone Technology Co., Ltd.

www.silverstonetek.com

support@silverstonetek.com
NO.G11243300