



CELEBRATING AN ICON

Born in Pontedera, Italy, in 1946, the Vespa was the perfect symbol of a bright new future. It quickly became more than just a means of transport, representing both the joy of living and modern fashion. With more than 75 years on the road, we thought it was the perfect time to celebrate this cultural icon and hope you'll enjoy building the LEGO® version of this classic vehicle.

CÉLÉBRATION D'UNE LÉGENDE

Créée en 1946 à Pontedera, en Italie, la Vespa était le symbole tout désigné d'un avenir prometteur. Elle est rapidement devenue bien plus qu'un simple moyen de transport, représentant à la fois la joie de vivre et la mode moderne. Après plus de 75 ans sur les routes, cette icône culturelle mérite d'être célébrée. Nous espérons que vous prendrez plaisir à construire la version LEGO® de ce véhicule classique.

HOMENAJE A UN ÍCONO

Nacida en Pontedera (Italia) en 1946, la Vespa era el símbolo perfecto de un nuevo y brillante porvenir. Pronto se convirtió en mucho más que un medio de transporte: representaba tanto la alegría de vivir como la modernidad urbana. Sus más de 75 años en la carretera nos parecieron un poderoso motivo para rendir homenaje a este ícono cultural. Esperamos que disfrutes construyendo la versión LEGO® de este clásico vehículo.

The Vespa's story has been long and successful, crossing borders and oceans, taking Italian style to the roads all over the world for over 75 years.

La Vespa est forte d'une longue et fructueuse histoire au-delà des frontières et des océans, transportant le style italien sur les routes du monde entier depuis plus de 75 ans.

La Vespa puede presumir de una larga trayectoria tapizada de éxitos que ha traspasado fronteras y cruzado océanos impregnando de sabor italiano y estilo las carreteras de todo el mundo durante más de 75 años.

Synonymous with performance and reliability, the Vespa GS (Gran Sport) became the queen of regularity rallies in the second half of the 1950s.

Sinónimo de desempeño y confiabilidad, la Vespa GS (Gran Sport) se convierte en la reina de las carreras de regularidad en la segunda mitad de la década de 1950.

Synonyme de performance et de fiabilité, la Vespa GS (Gran Sport) devient la reine des rallyes de régularité dans la seconde moitié des années 1950.



1954

The "Chi Vespa mangia le mele" ("He who Vespas eats apples") launch campaign for the new Vespa Primavera 125 marked a revolution in the world of advertising.



La campagne de lancement de la nouvelle Vespa Primavera 125, intitulée « Chi Vespa mangia le mele » (« Celui qui roule en Vespa mange des pommes ») révolutionne le monde de la publicité.

La campaña de lanzamiento de la nueva Vespa Primavera 125, "Chi Vespa mangia le mele" ("Quien Vespa come manzanas"), supone toda una revolución en el mundo de la publicidad.

1968

1946

On April 23rd, 1946, Piaggio filed the patent for a motorized vehicle with a 98cc single-cylinder 2-stroke engine. Vespa was born.

El 23 de abril de 1946, Piaggio inscribe en la oficina de patentes un vehículo motorizado con motor monocilíndrico de 2 tiempos y 98 cc de cilindrada. Nace la Vespa.

Le 23 avril 1946, Piaggio dépose une demande de brevet pour un véhicule motorisé avec un moteur monocylindre à deux temps de 98 cm³. La Vespa voit le jour.



1963



The Vespa 50cc became an instant success among young people, who could ride it without needing a driver's license.

La Vespa 50 cm³ connaît un succès immédiat auprès des jeunes, qui peuvent la conduire sans devoir obtenir un permis de conduire.

La Vespa de 50 c. c. triunfa de inmediato entre los jóvenes, que podían manejarla sin licencia de conducir.

With more than three million sold, the PX became the most successful Vespa model of all times.

Avec plus de trois millions d'unités vendues, la PX devient le modèle de Vespa le plus populaire de tous les temps.



1978

Con más de tres millones de unidades vendidas, el modelo Vespa PX llega a ser el más exitoso de todos los tiempos.



The GTS 250 continued the tradition of sporty Vespa. The body was widened in order to improve the room for rider, passenger and baggage.

La GTS 250 perpétue la tradition de la Vespa sportive. La carrosserie élargie offre plus d'espace pour le conducteur, le passager et les bagages.

La GTS 250 continúa la tradición de la Vespa deportiva. El chasis se ensancha para ofrecer más espacio al conductor, el pasajero y el equipaje.

2006

Vespa celebrates its 75th anniversary with the Vespa 75th special edition, reinforcing the brand's status as a fashion icon.

Vespa fête son 75^e anniversaire avec la Vespa 75^e édition, qui confirme le statut d'icône de la mode de la marque.



Vespa celebra su 75 aniversario con la Vespa 75th, una edición especial que refuerza el estatus de la marca como ícono de la moda.

2021

With the 50 ET Vespa enters the third millennium without losing its elegant, pleasant, and instantly recognizable lines that have always distinguished it.



1996

Avec la 50 ET, Vespa fait son entrée dans le troisième millénaire sans perdre ses lignes caractéristiques élégantes et attrayantes qui l'ont toujours distinguée.

La 50 ET introduce a Vespa en el tercer milenio sin perder las elegantes, estéticas e instantáneamente reconocibles líneas que siempre la distinguieron.

With the Elettrica, you could negotiate the city streets in absolute silence, whether you opted for the Eco energy-saving mode or for the Power setting.



2019

Avec l'Elettrica, vous pouvez parcourir les rues sans le moindre bruit, que vous optiez pour le mode écologique d'économie d'énergie ou pour le réglage de puissance.

Con la Elettrica, puedes recorrer las calles de la ciudad en absoluto silencio, tanto si optas por el modo Eco de ahorro de energía como por el modo Power, que utiliza el motor a su máxima potencia.



THE PERFECT NAME

Legend has it that when designer Corradino D'Ascanio presented his prototype to Enrico Piaggio, the manufacturer took one look at the vehicle's distinct body shape and antenna-like handlebars and exclaimed: "Sembra una vespa!" ("It looks like a wasp!"). When the sound of the engine was heard, it became even clearer that the perfect name had been found.

EL NOMBRE PERFECTO

Cuenta la leyenda que, cuando el diseñador Corradino D'Ascanio presentó su prototipo a Enrico Piaggio, el empresario miró la distintiva forma del chasis del vehículo y su manubrio semejante a unas antenas, y exclamó: "Sembra una vespa!" ("¡Parece una avispa!"). El sonido del motor corroboró que se había encontrado el nombre perfecto.

LE NOM PARFAIT

La légende veut que lorsque le concepteur Corradino D'Ascanio a présenté son prototype à Enrico Piaggio, le constructeur aurait jeté un coup d'œil à la silhouette distinctive du véhicule et au guidon rappelant des antennes avant de s'exclamer : « Sembra una vespa! » (« On dirait une guêpe! »). Lorsque le moteur s'est fait entendre, il est devenu encore plus clair que le nom parfait avait été trouvé.

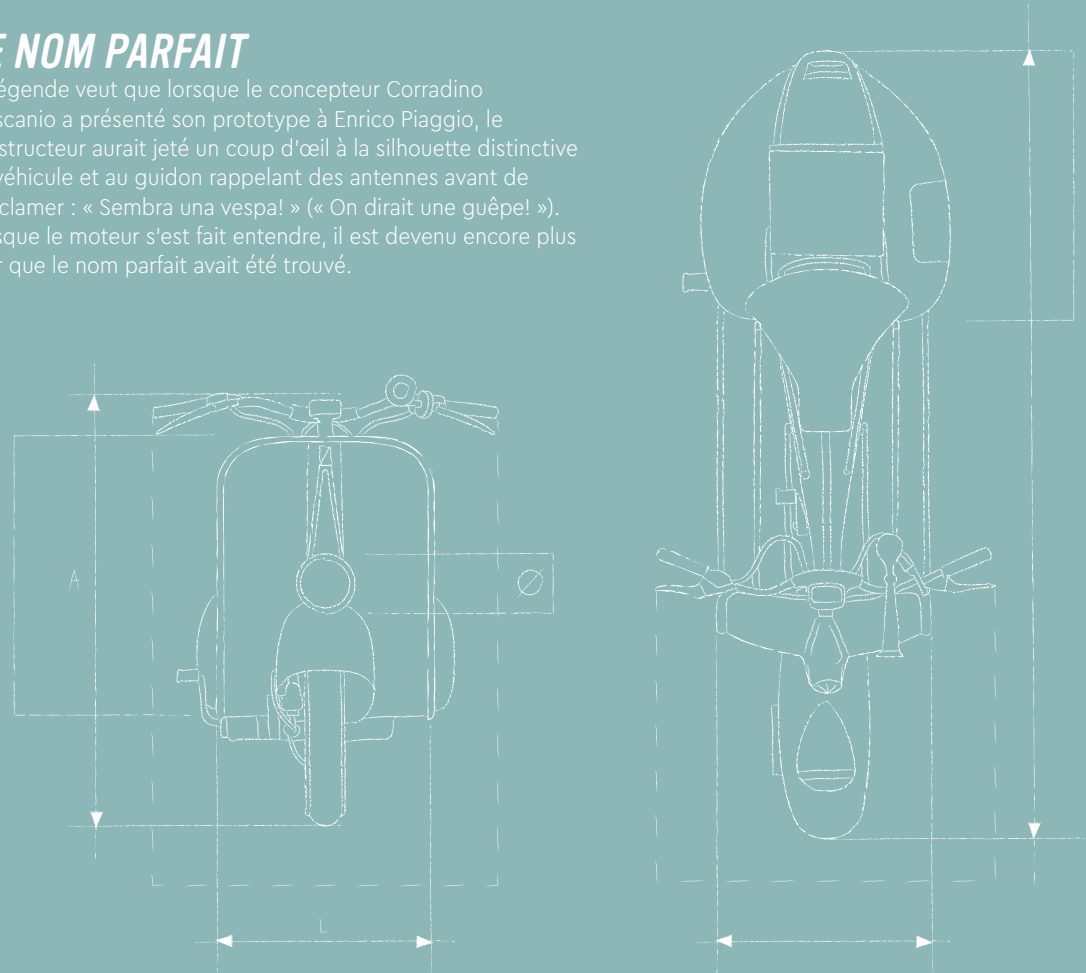
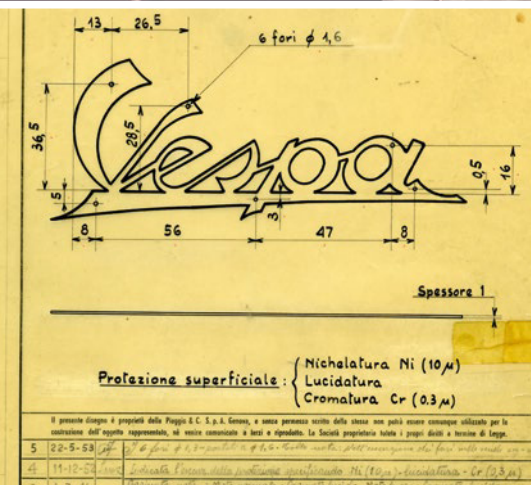

FROM THE DESIGN TEAM

"The biggest challenge for us was recreating the Vespa's organic rounded shapes in LEGO® elements. It took some time, but once this was achieved, we could start adding all those small but important details like the removable engine cover, kick-starter and pedals. Lastly, we worked on fun touches like the detachable flower basket and helmet with goggles to celebrate the iconic Dolce Vita feeling of the Vespa 125 from the mid-sixties."

Florian Müller, Senior Designer

UN MOT DE L'ÉQUIPE DE CONCEPTION

« Le plus grand défi pour nous a été de recréer les formes organiques arrondies de la Vespa avec des éléments LEGO®. Cela nous a pris un certain temps, mais une fois cette étape franchie, nous avons pu commencer à ajouter tous les petits détails importants, comme le capot amovible du moteur, le démarreur et les pédales. Enfin, nous avons ajouté des touches amusantes, comme le panier de fleurs amovible et le casque avec des lunettes, pour célébrer l'esprit de la "dolce vita" de la Vespa 125 du milieu des années 1960. »

Florian Müller, concepteur principal

IMPRESIONES DEL EQUIPO DE DISEÑO

"El mayor desafío al que nos enfrentamos fue recrear las redondeadas formas orgánicas de la Vespa con elementos LEGO®. Nos llevó un tiempo, pero una vez lo logramos, pudimos empezar a incorporar todos sus pequeños e importantes detalles, entre los que destacan la cubierta del motor removible, el pedal de arranque y los pedales. Luego nos ocupamos de los divertidos toques finales, como la cesta de flores extraíble y el casco con lentes, para celebrar el mítico espíritu de la dulce vida que identifica a la Vespa 125 de mediados de los años sesenta".

Florian Müller, diseñador sénior



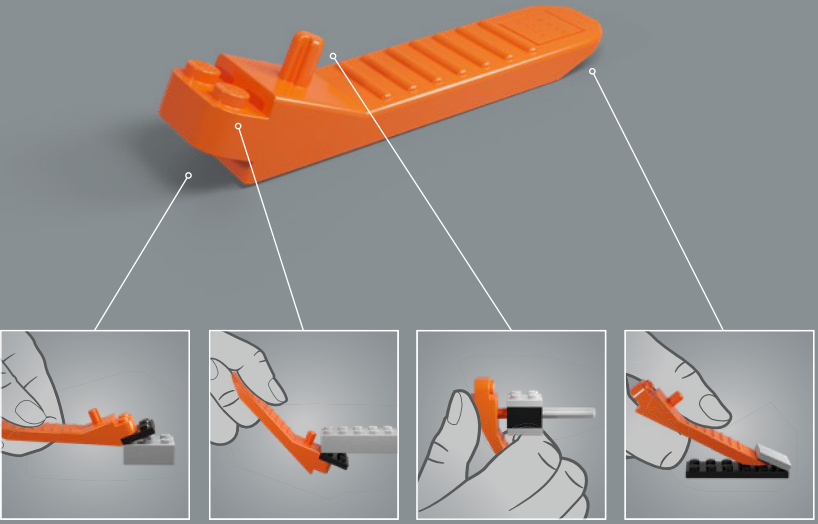
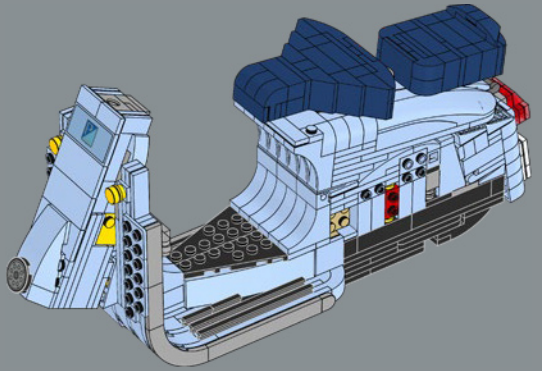
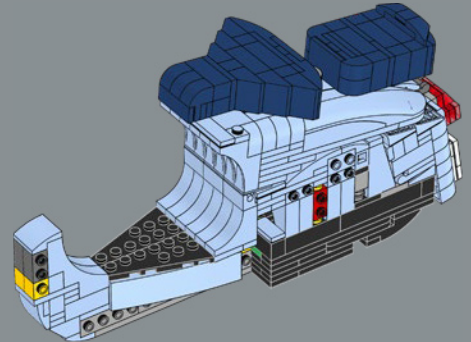
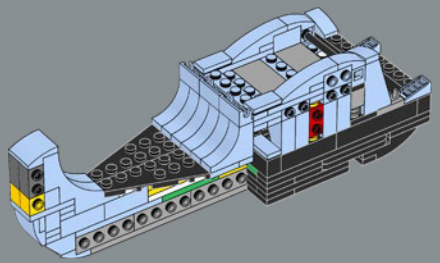

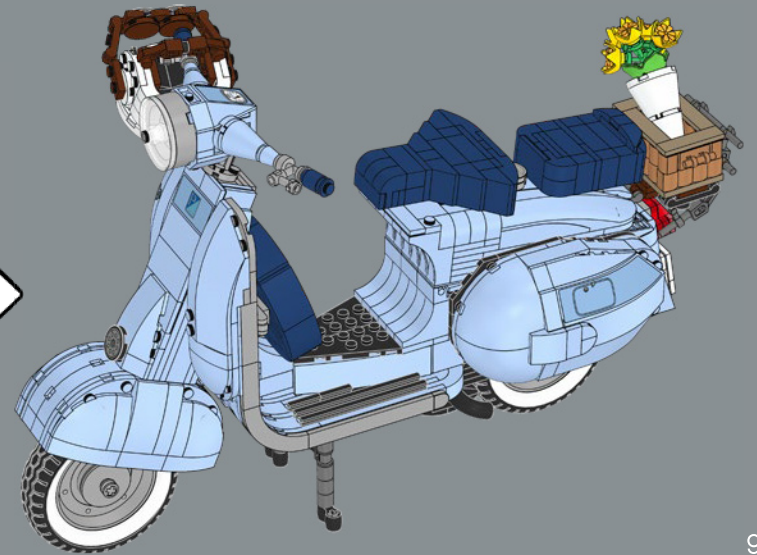
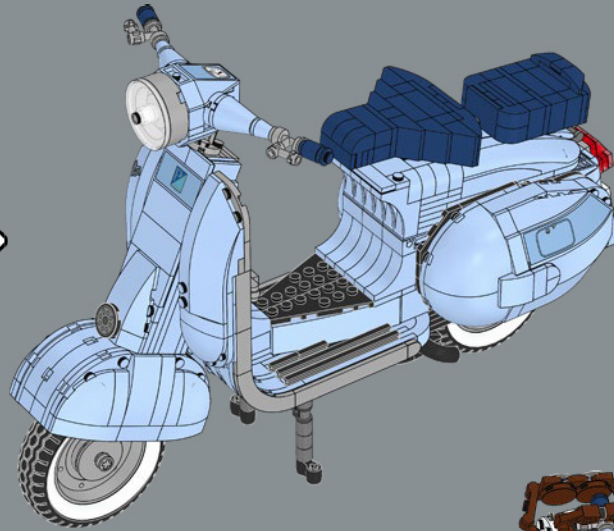
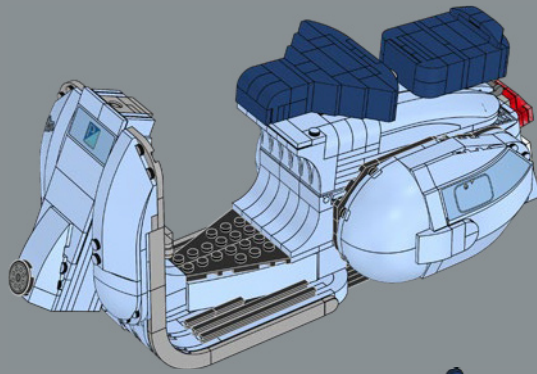

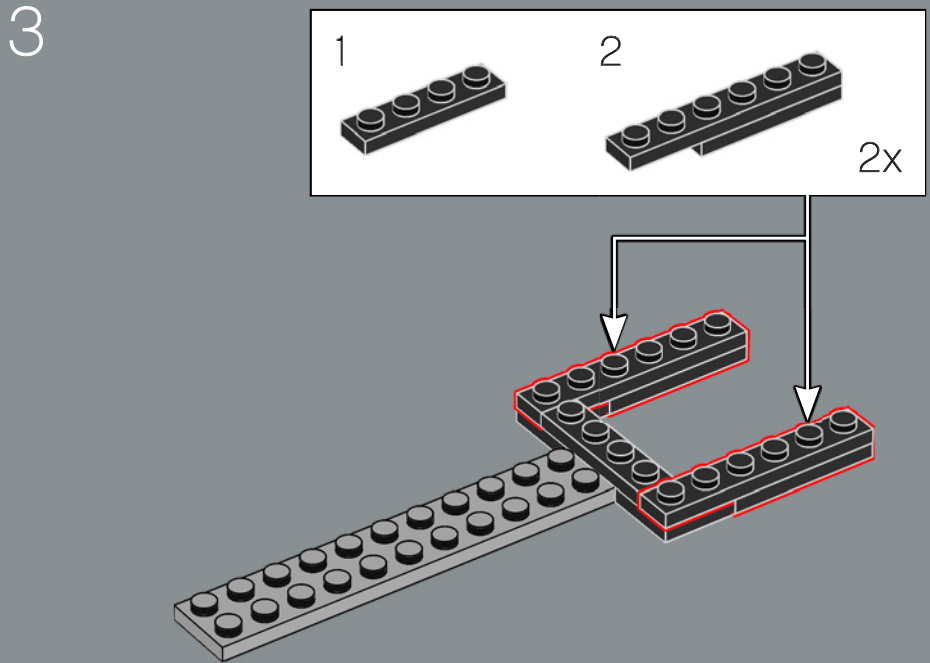
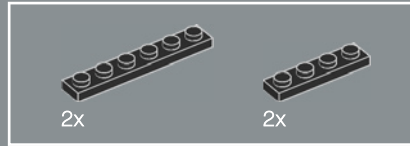
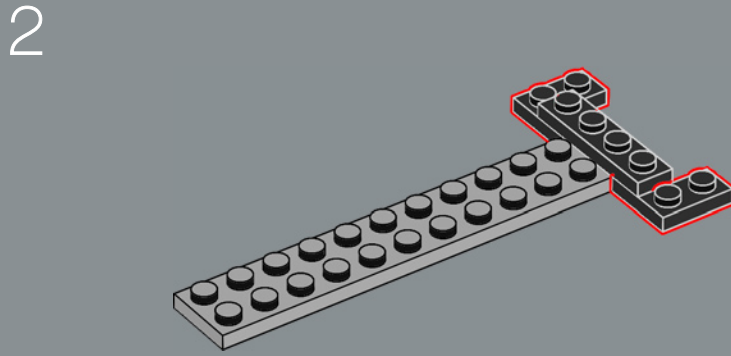
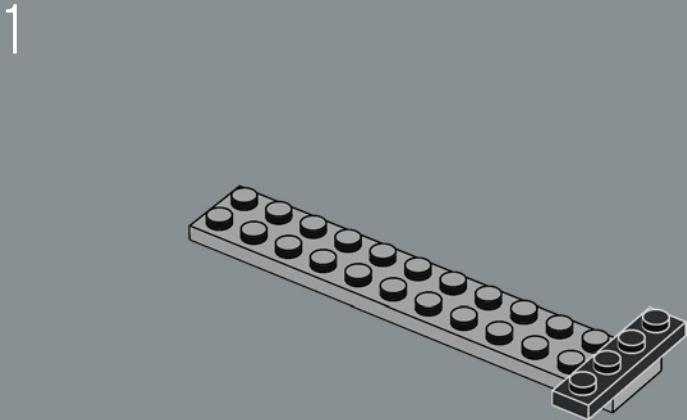
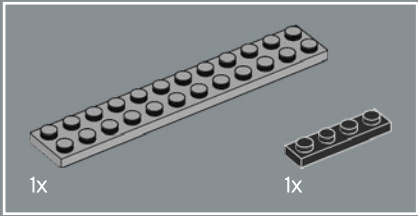
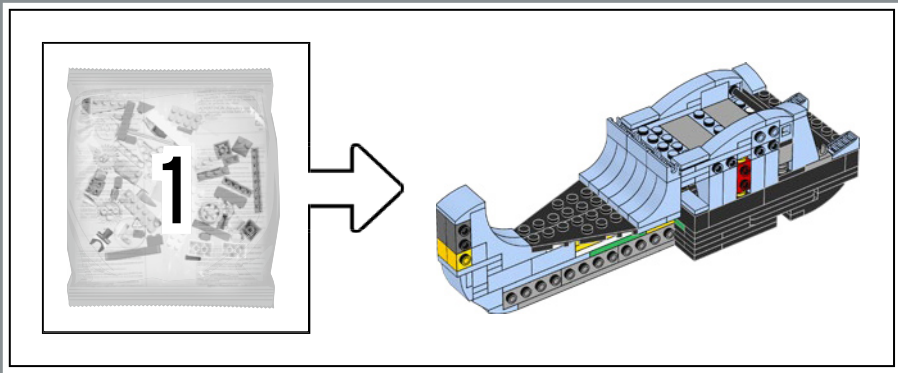



4

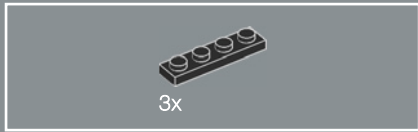
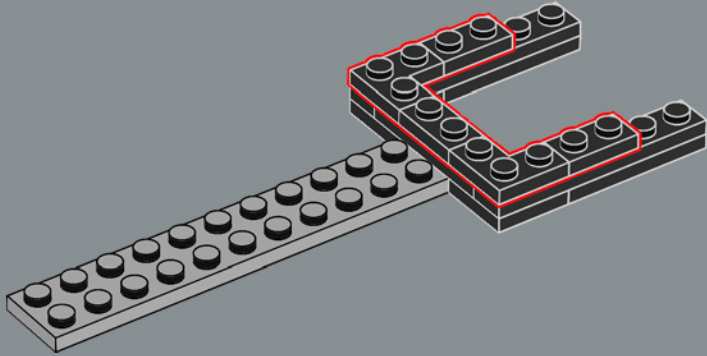

5

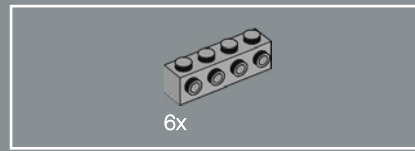
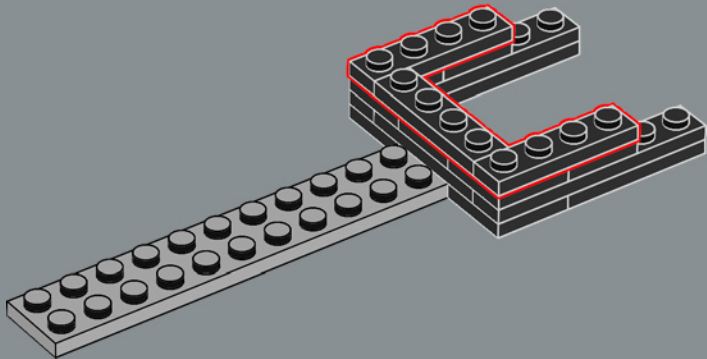

6

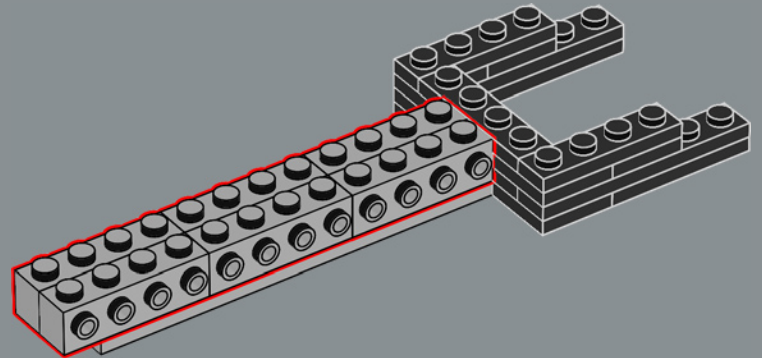

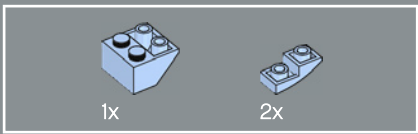

7

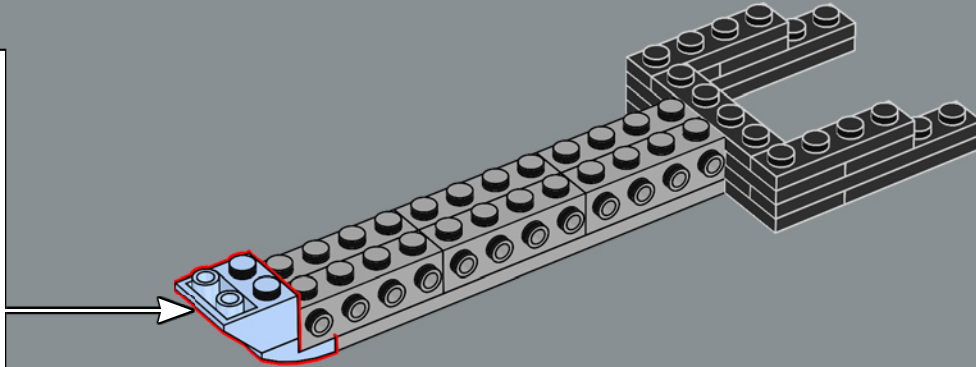
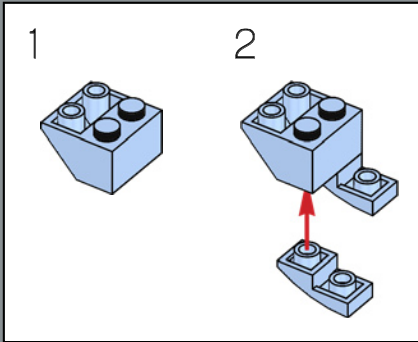

The pastel blue shade that matches the original Vespa is a very rarely used LEGO® color.

La teinte bleu pastel de la Vespa originale est une couleur LEGO® très rarement utilisée.

El tono azul pastel idéntico al de la Vespa original es un color LEGO® que rara vez se usa.

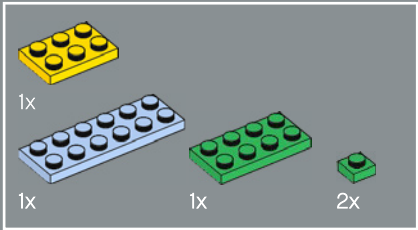

8

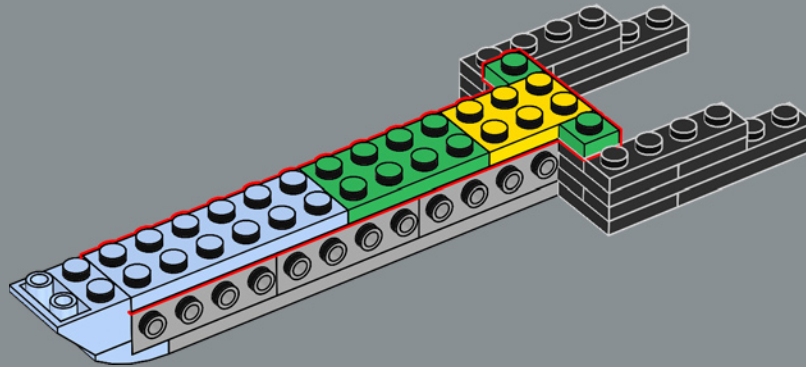

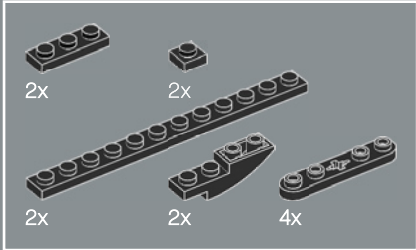
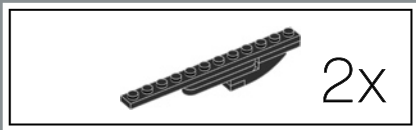

9

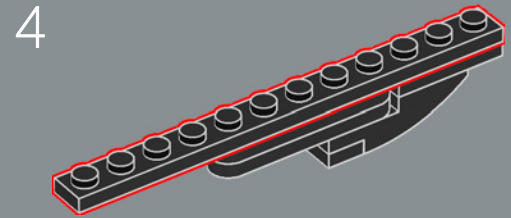
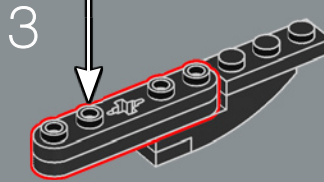
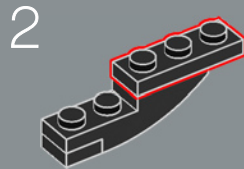
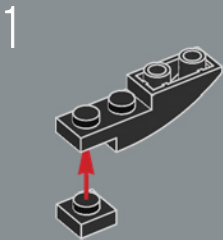

2x

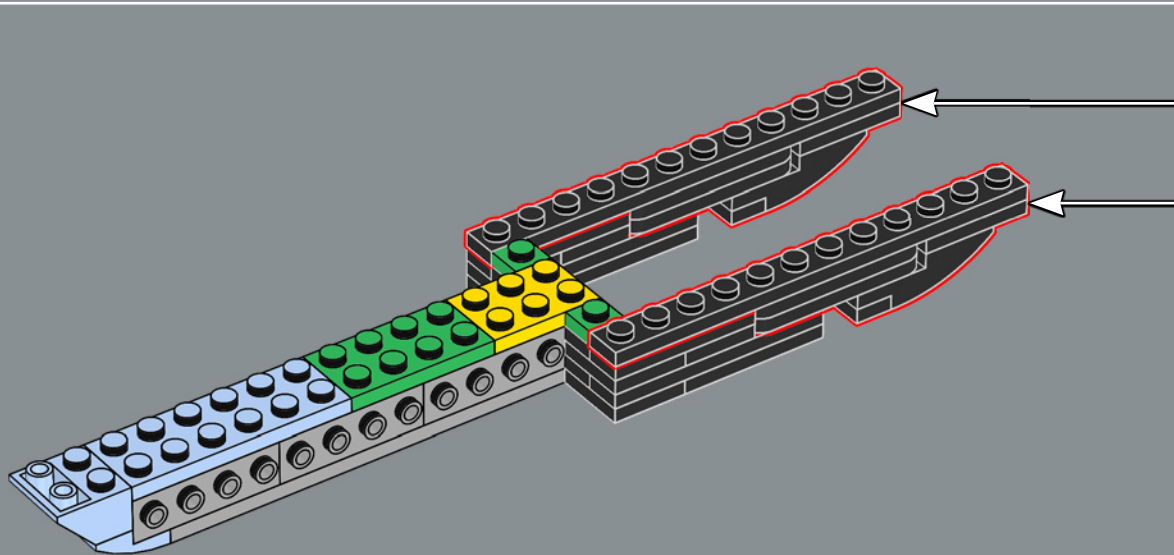

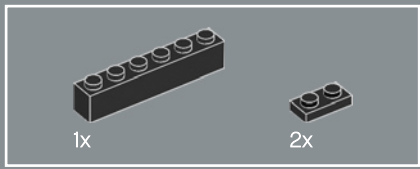

10

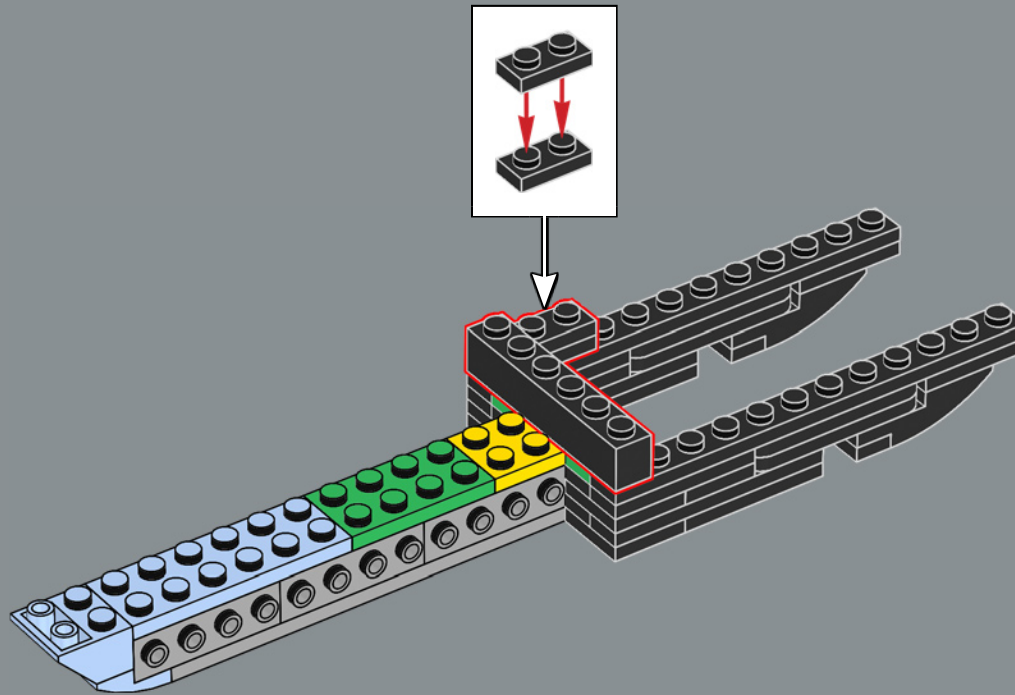

11

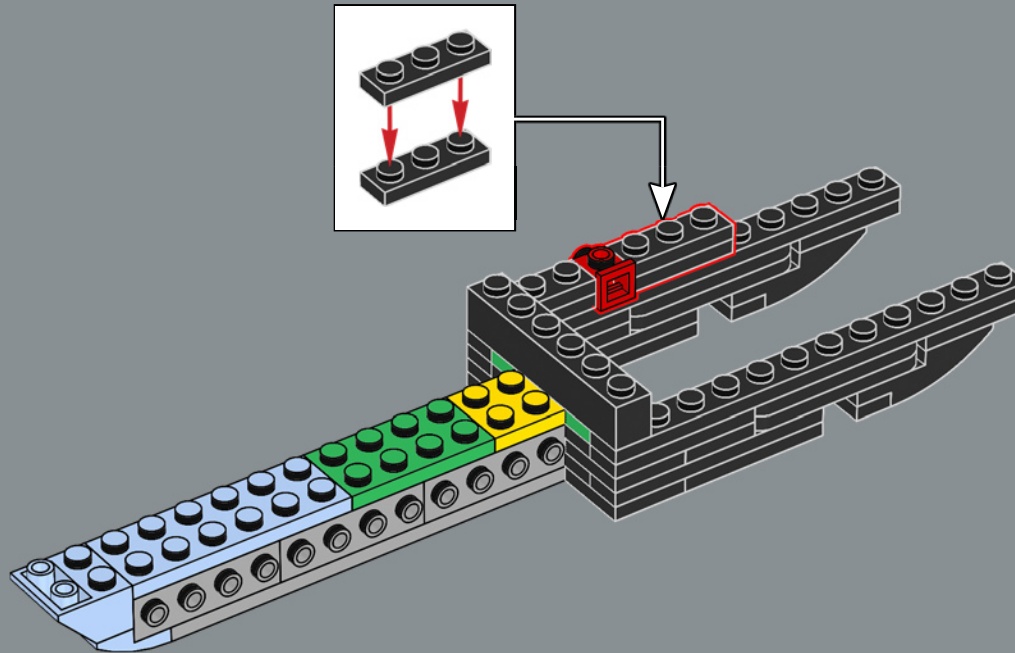

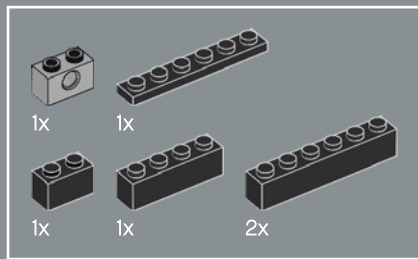

12

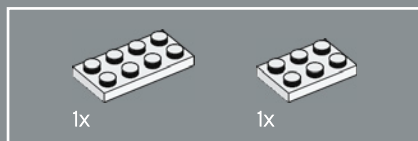
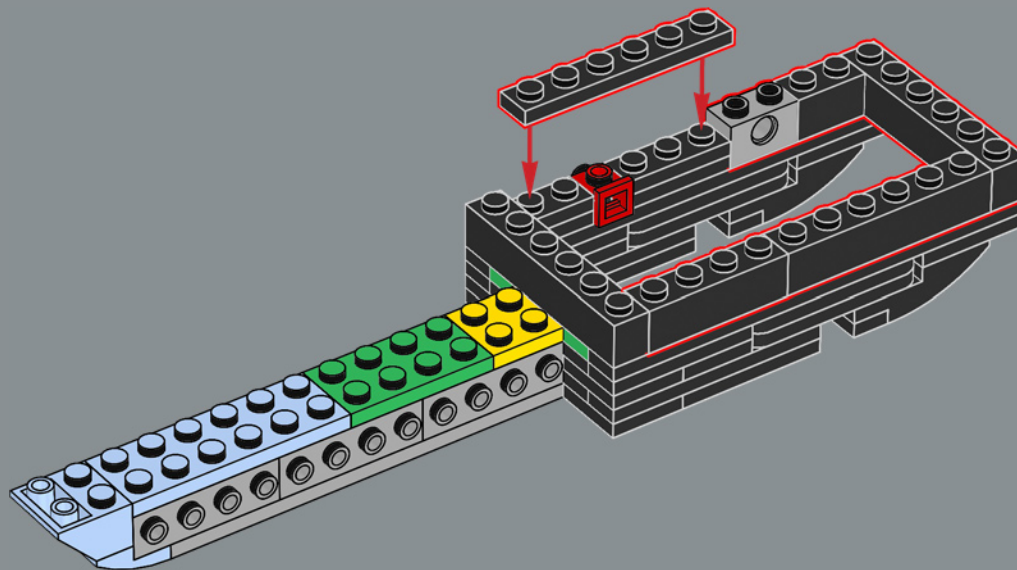

13

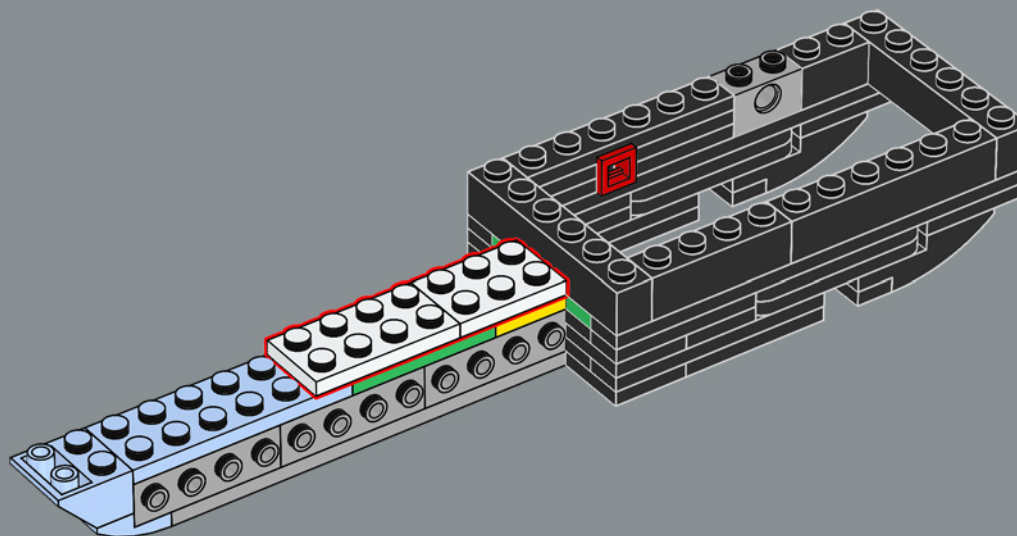

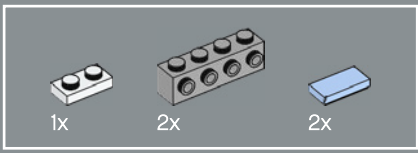

14

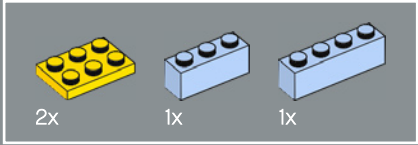
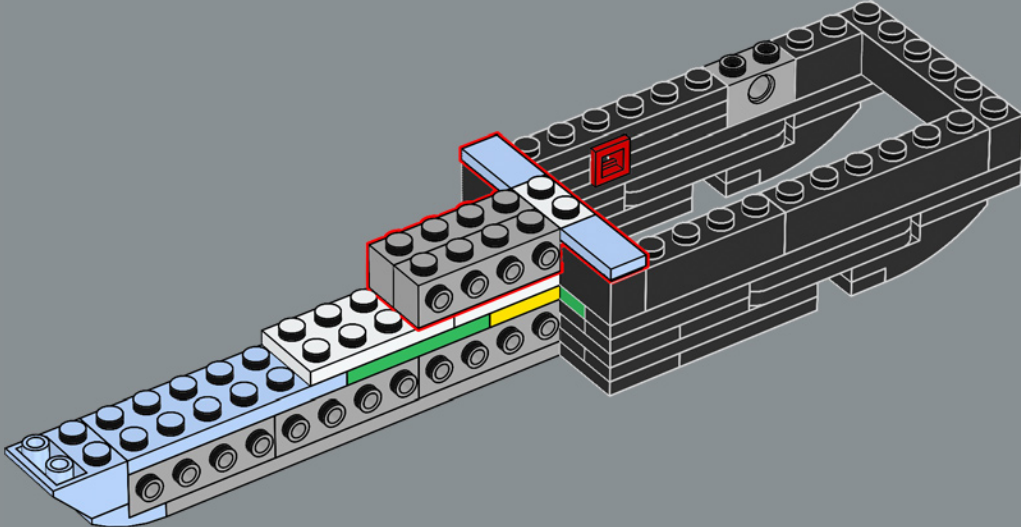

15

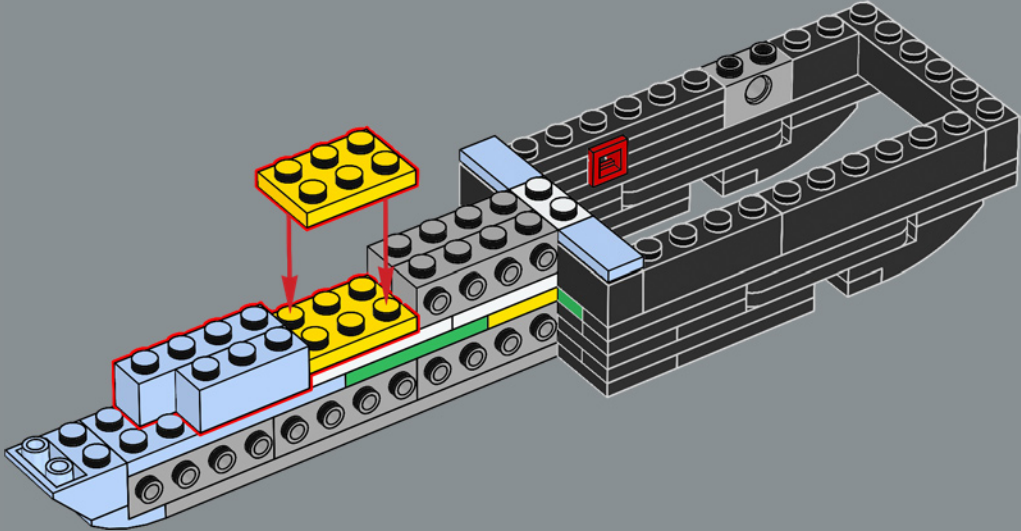

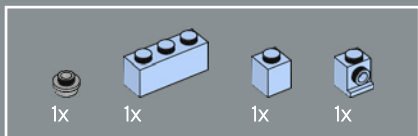

16

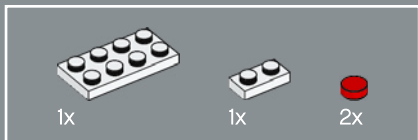
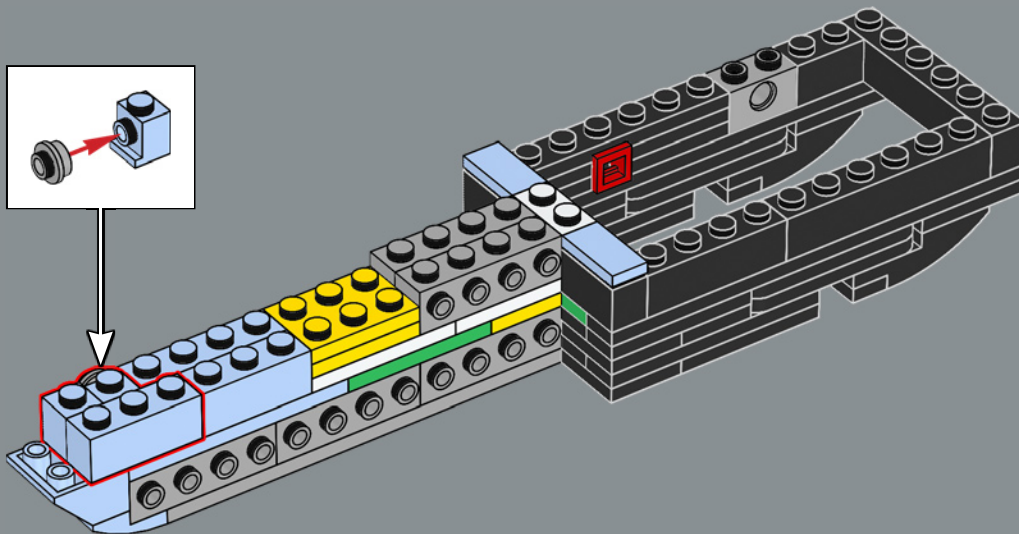
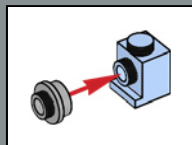

17

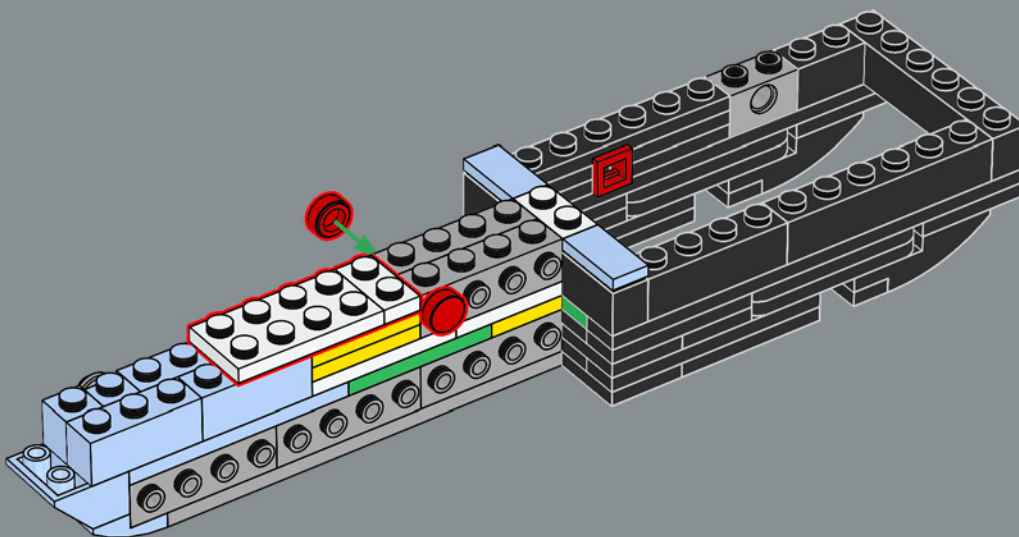

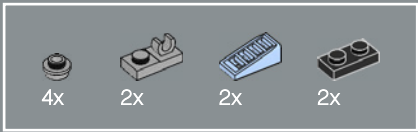

18

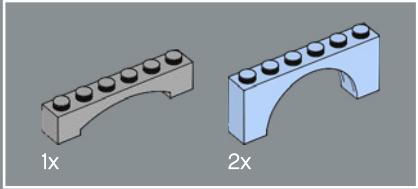
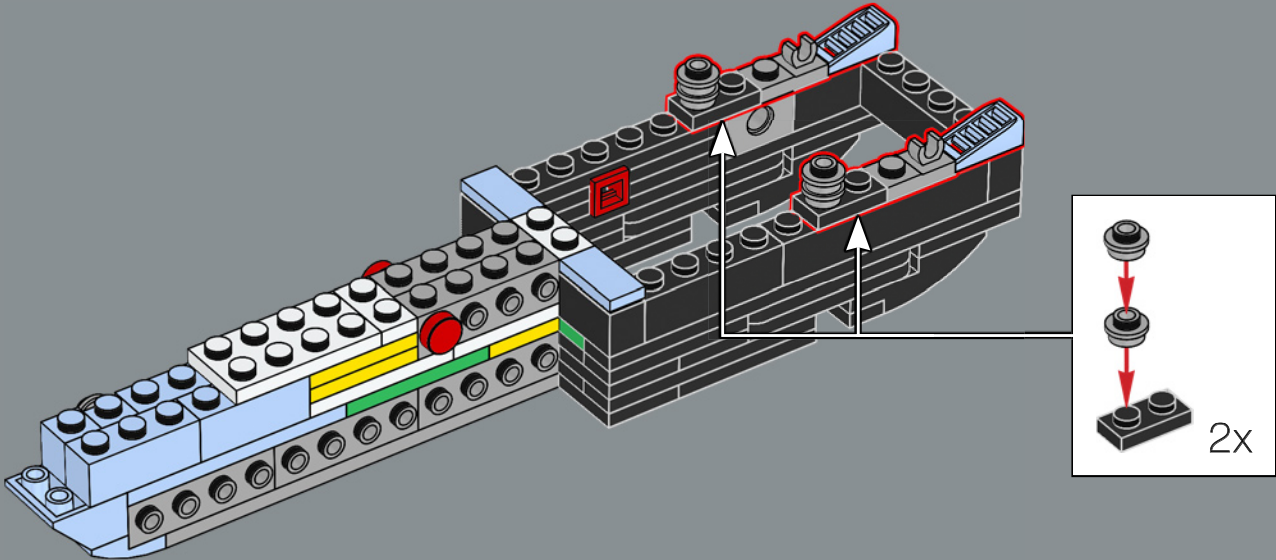

19

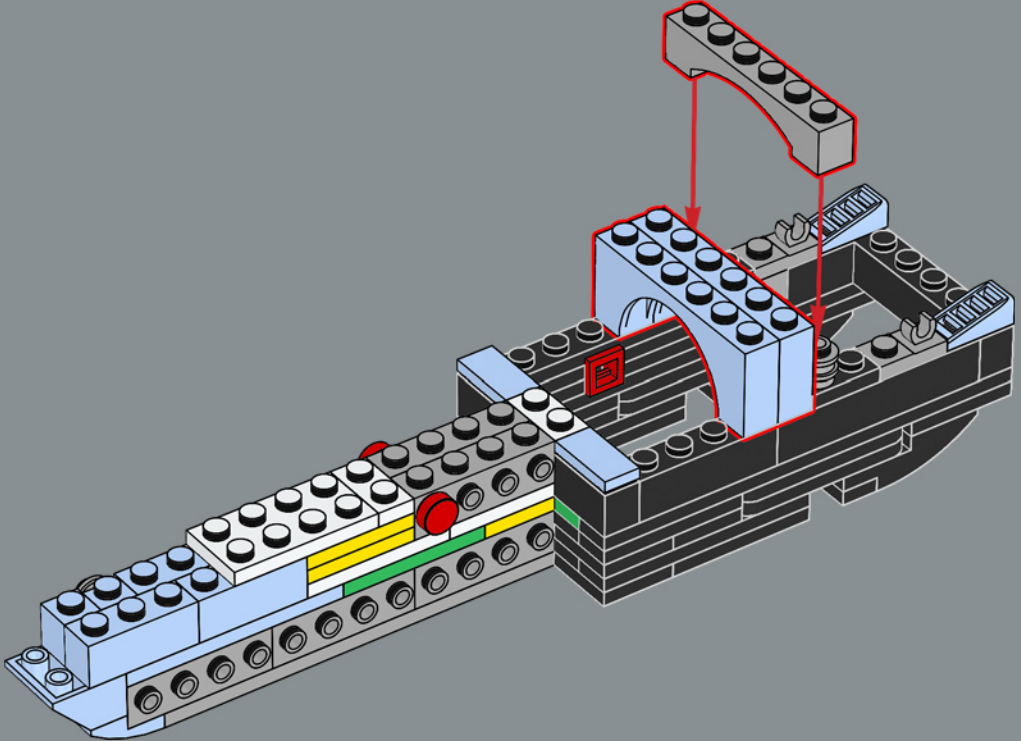



20

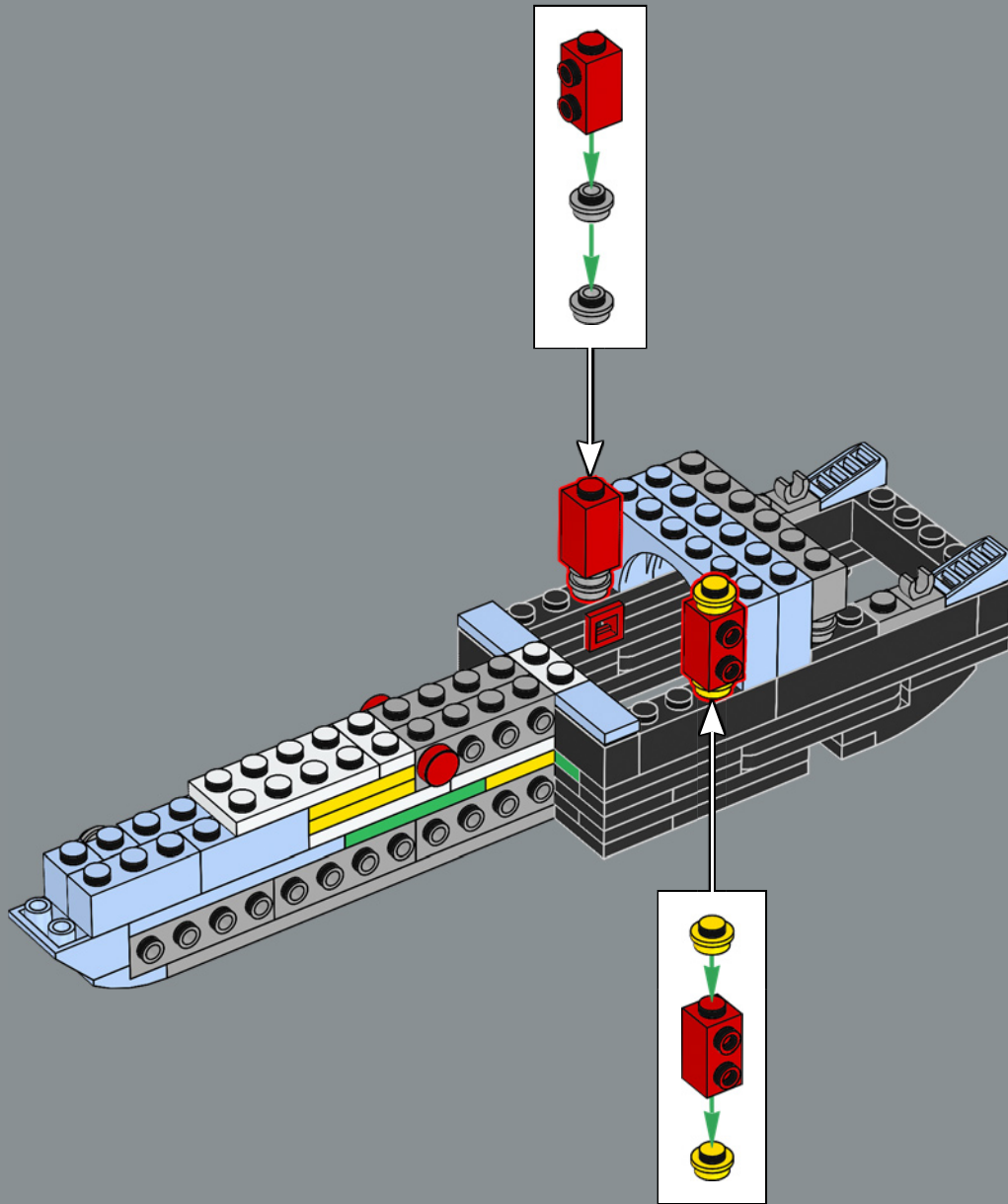

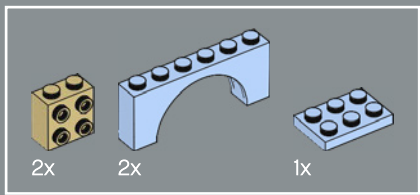

21

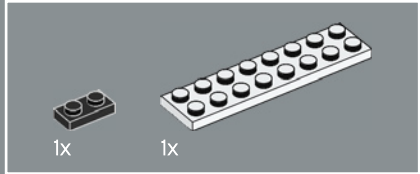
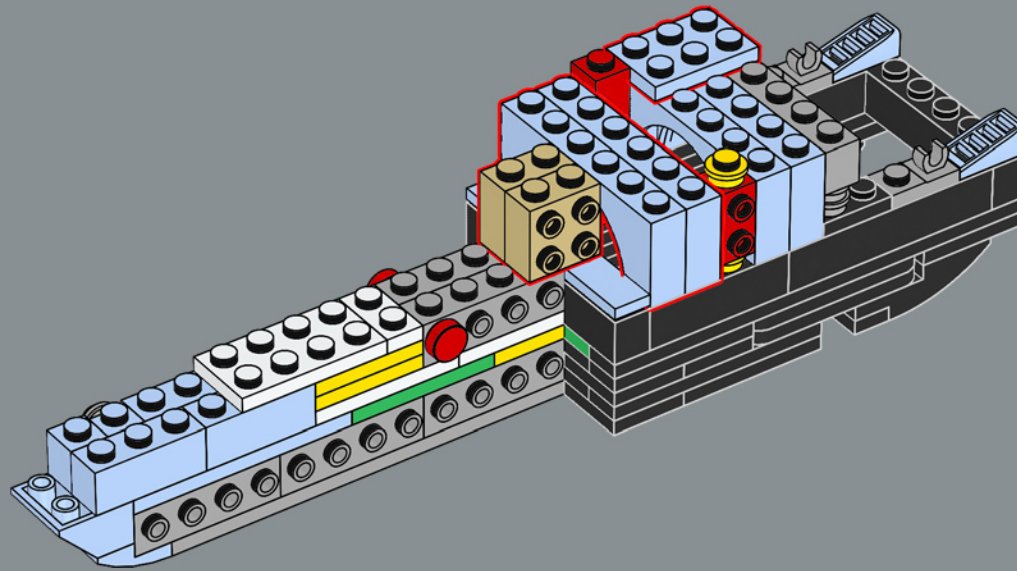

22

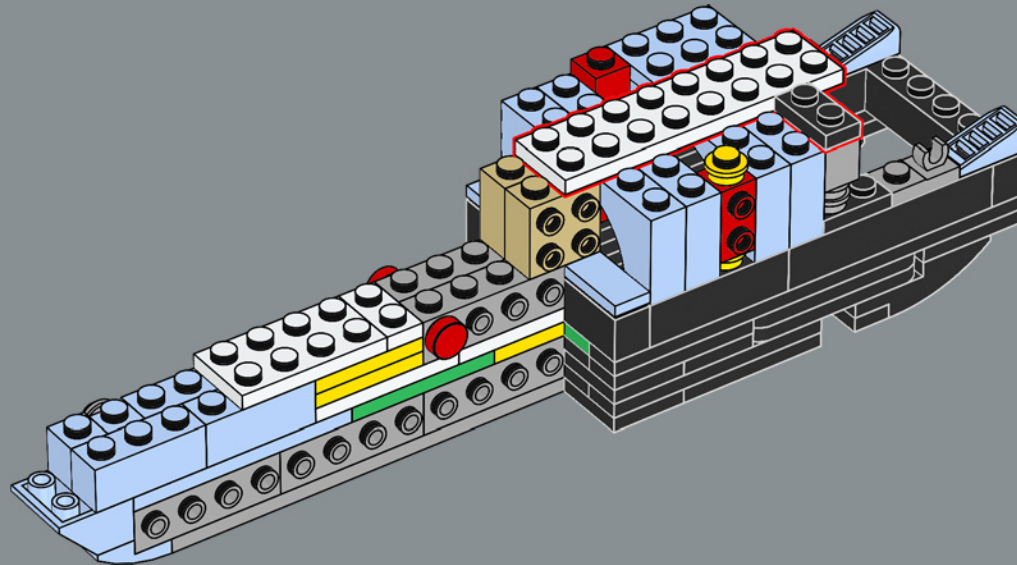

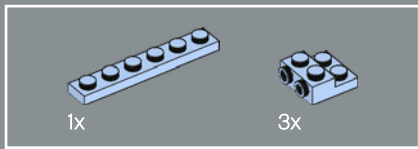

23

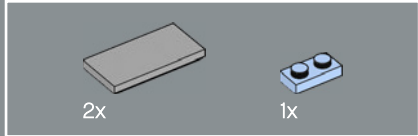
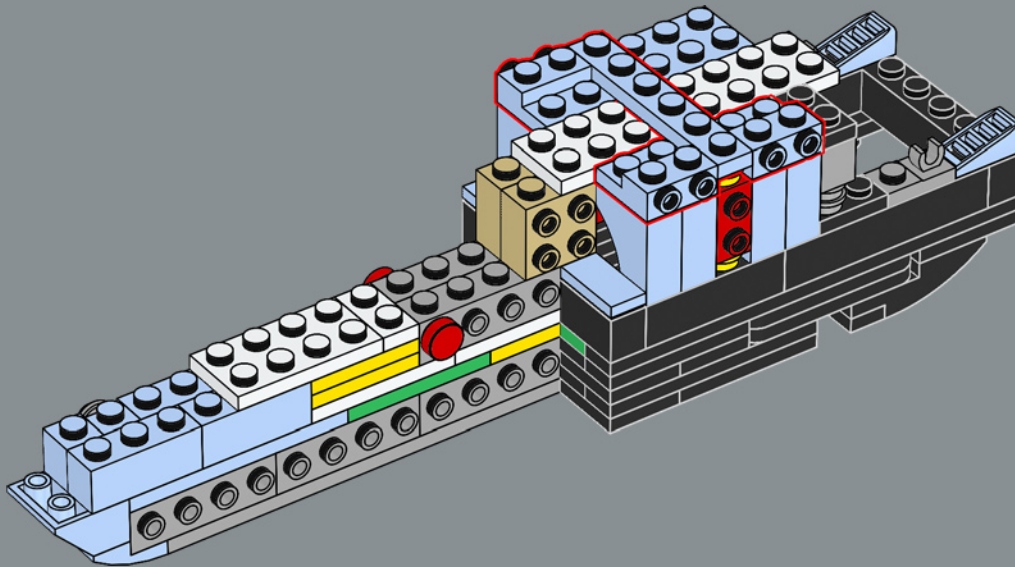

24

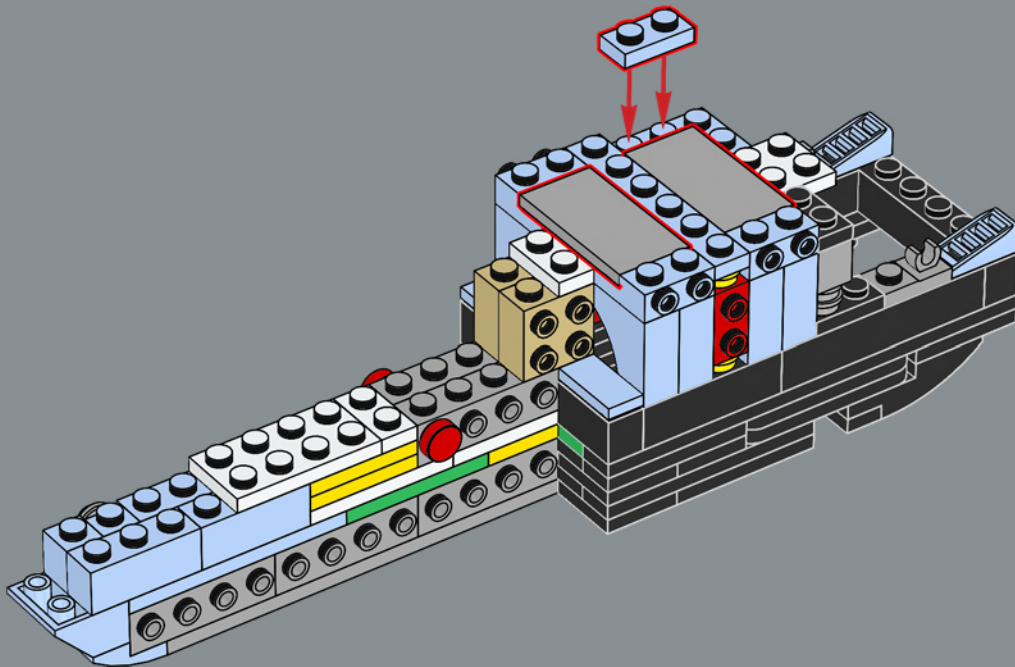

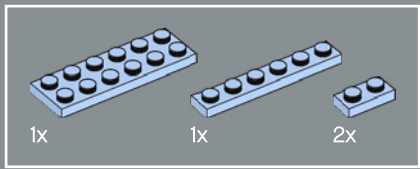

25

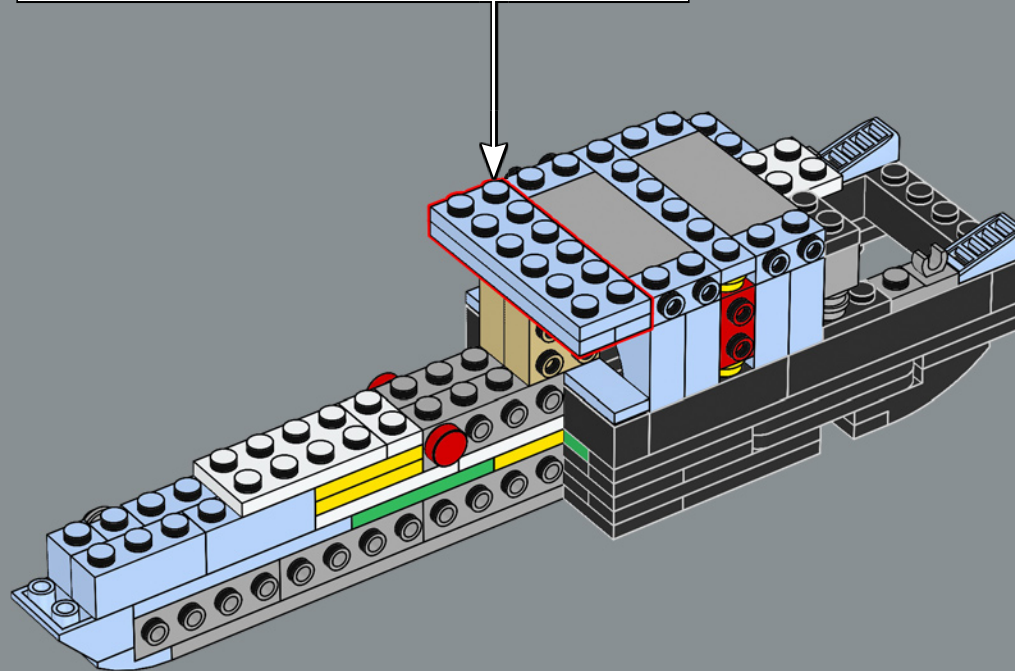
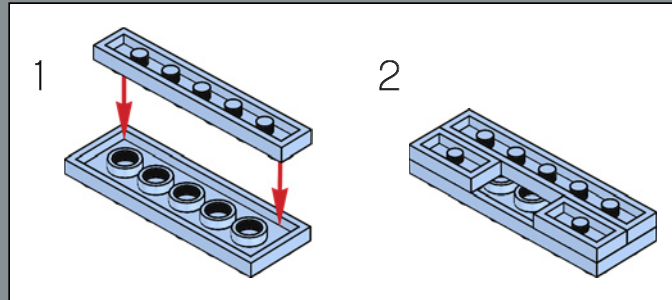

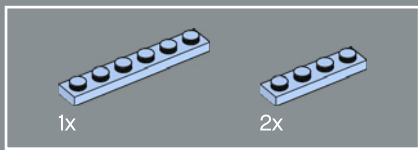

26

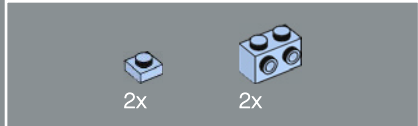
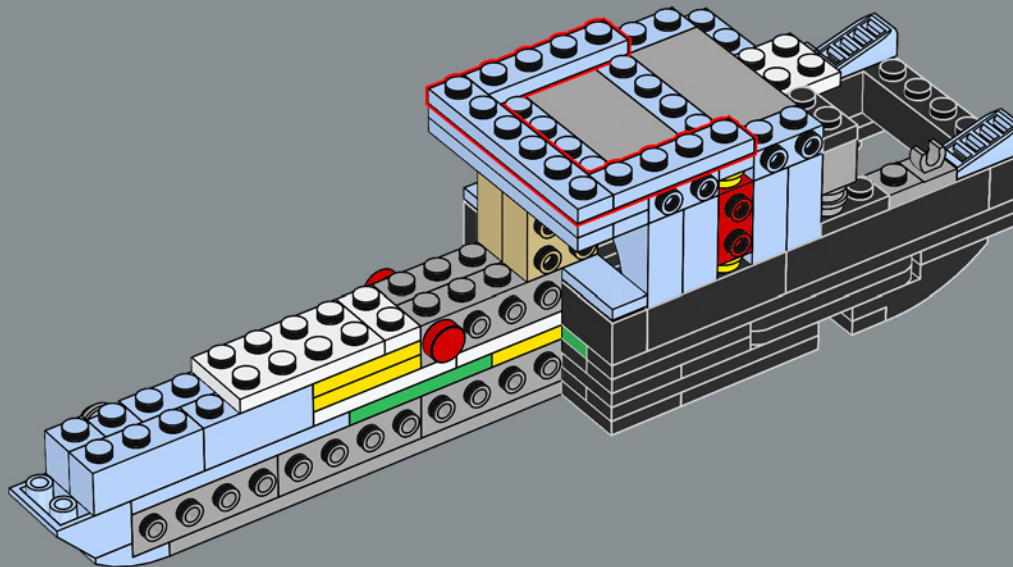

27

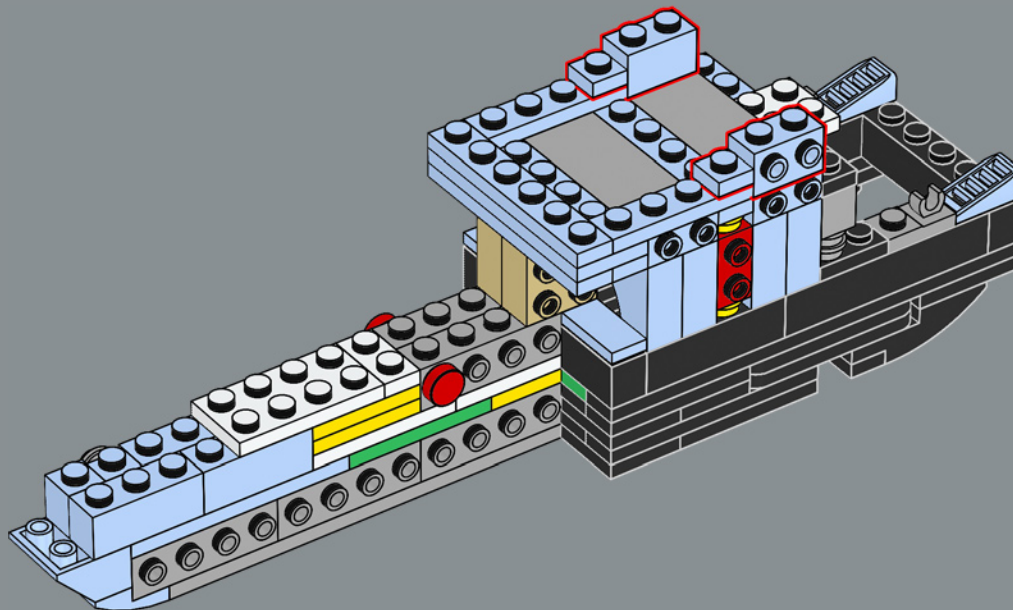



28

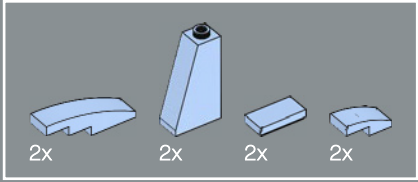
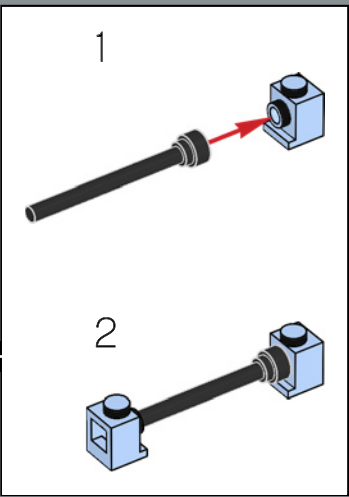
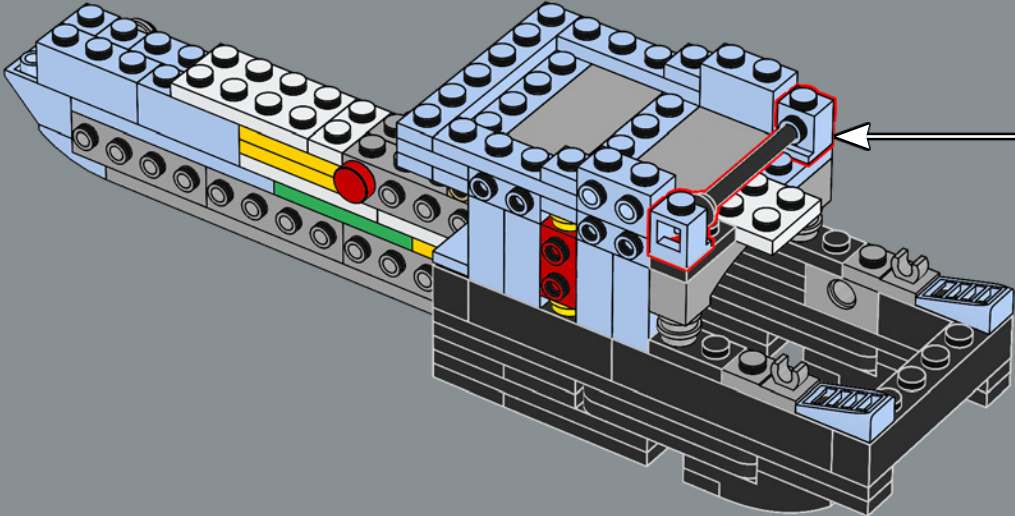

29

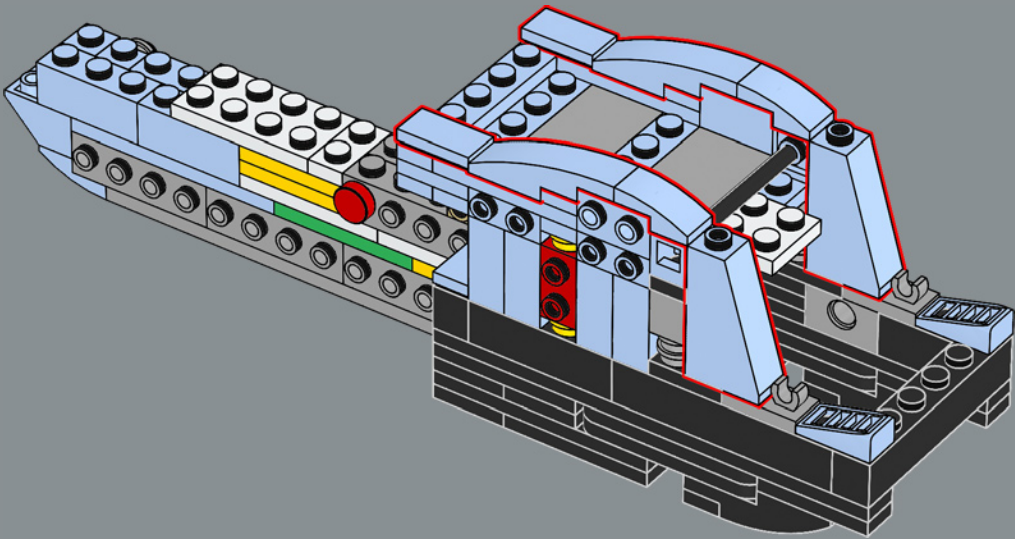

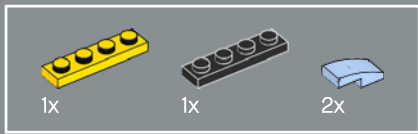

30

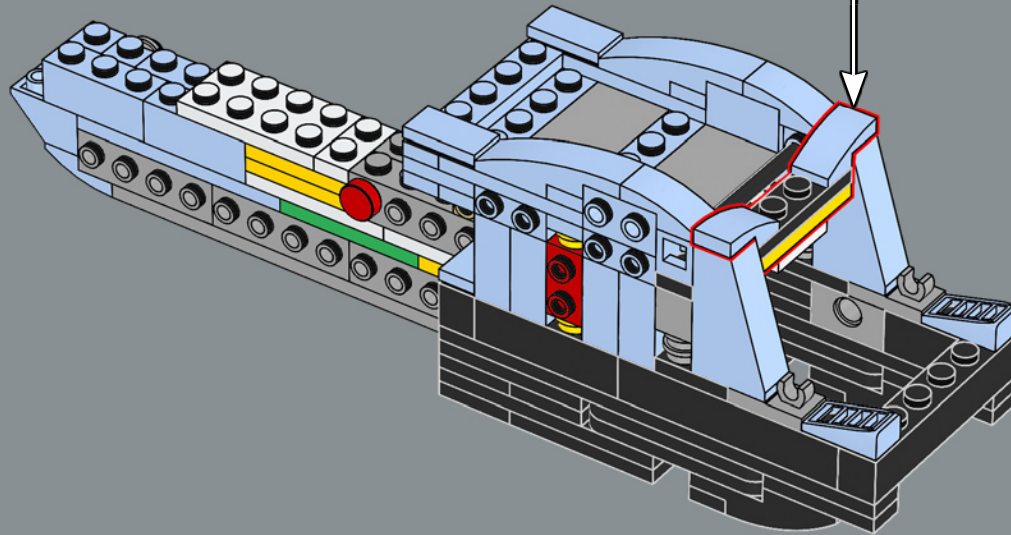
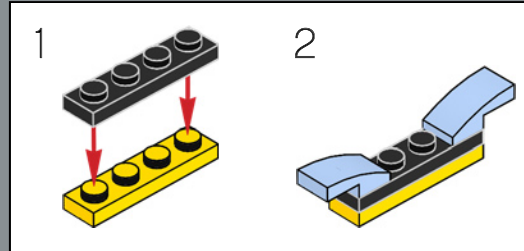

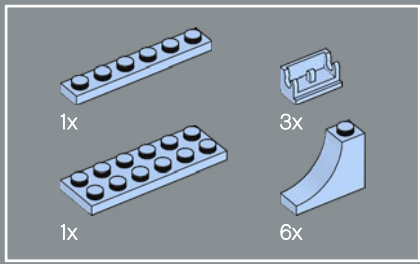

31

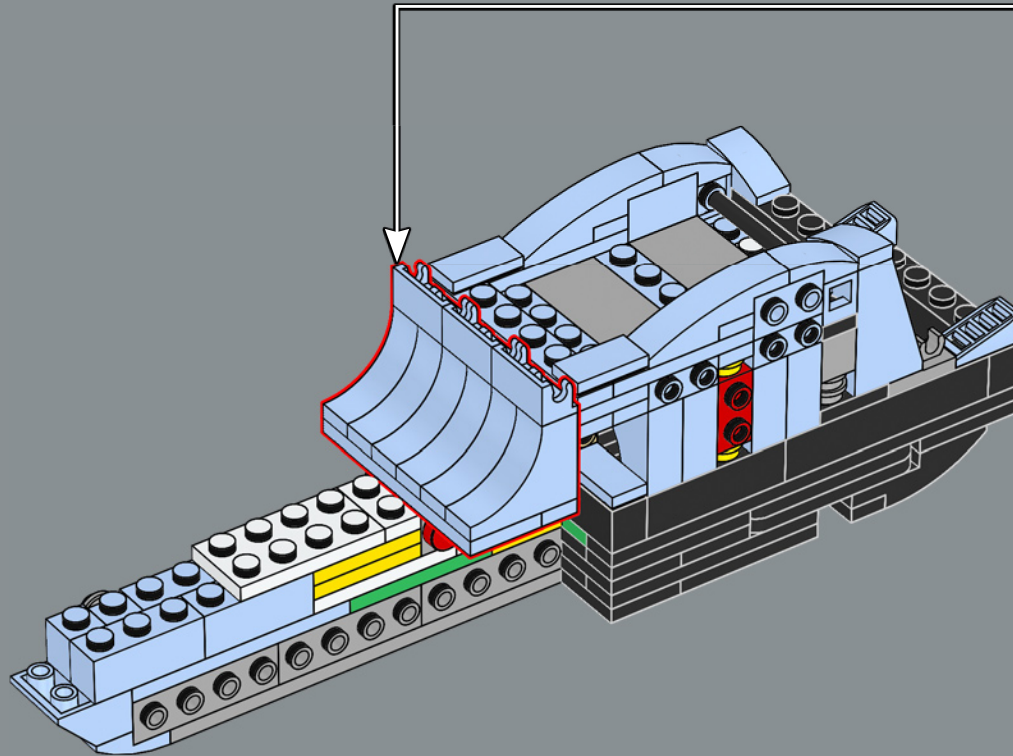
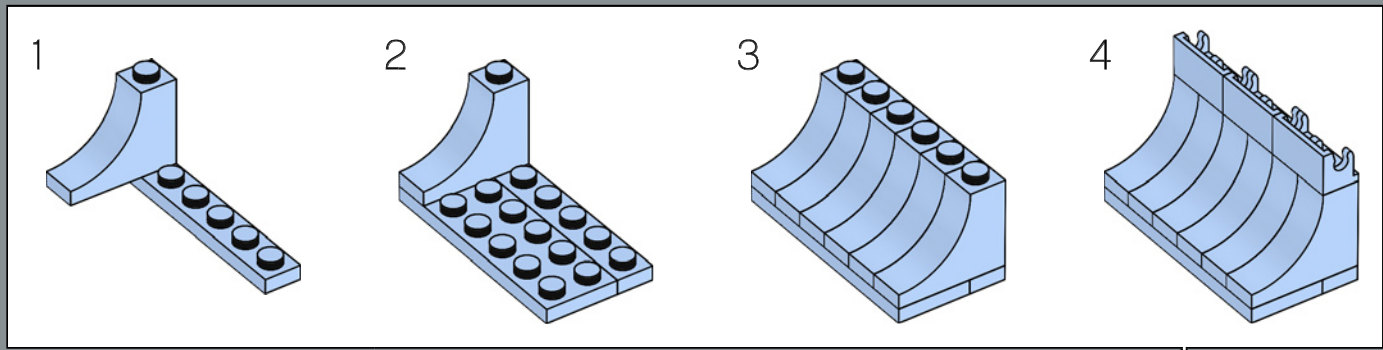

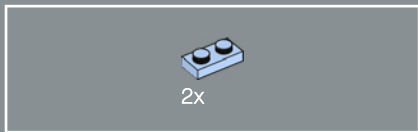

32

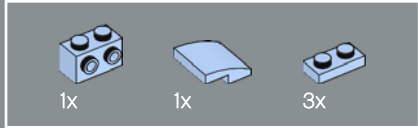
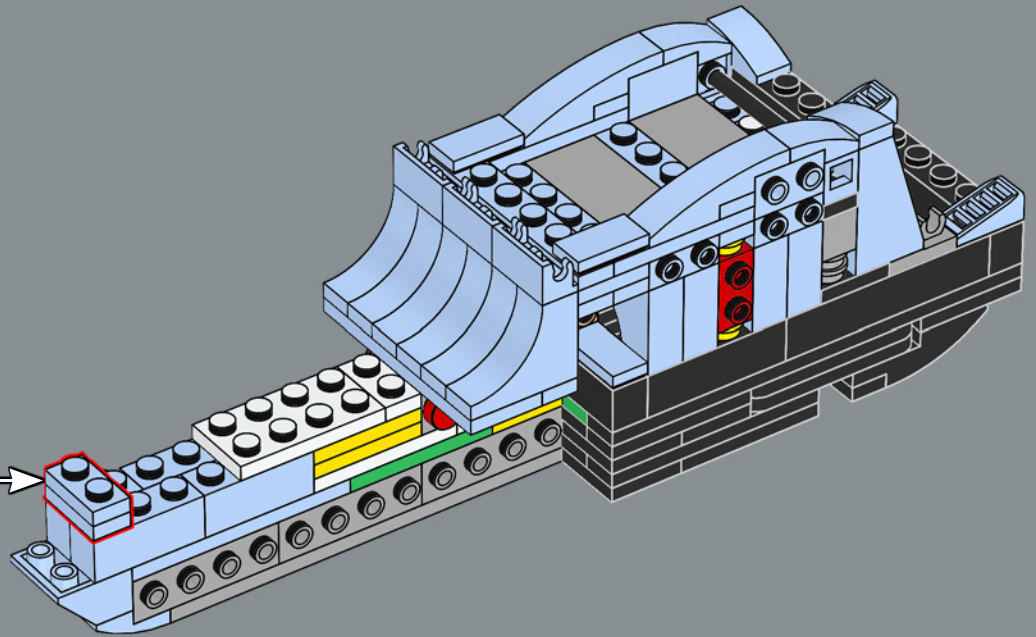
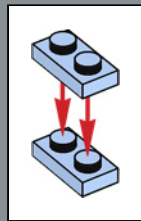

33

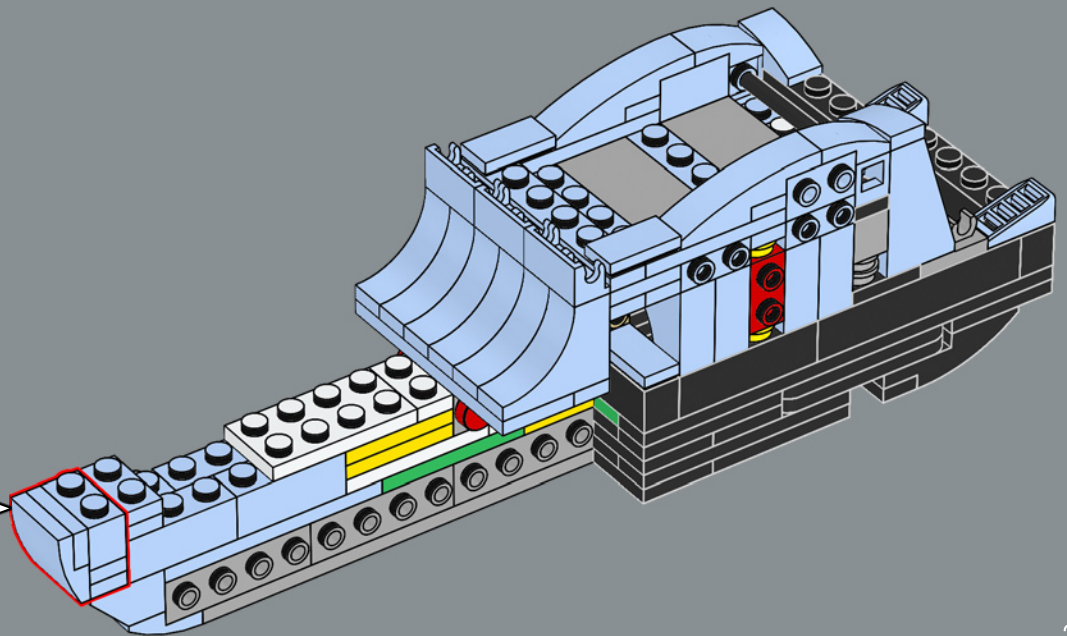
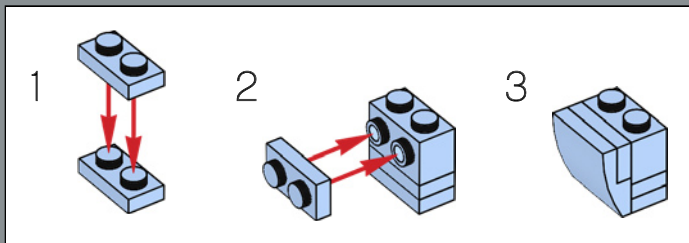

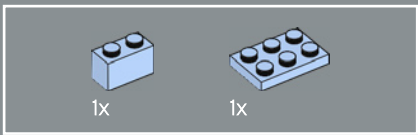

34

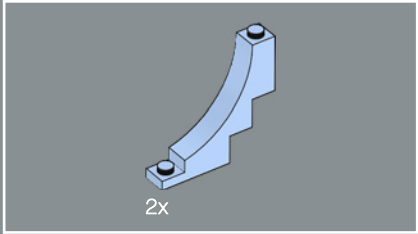
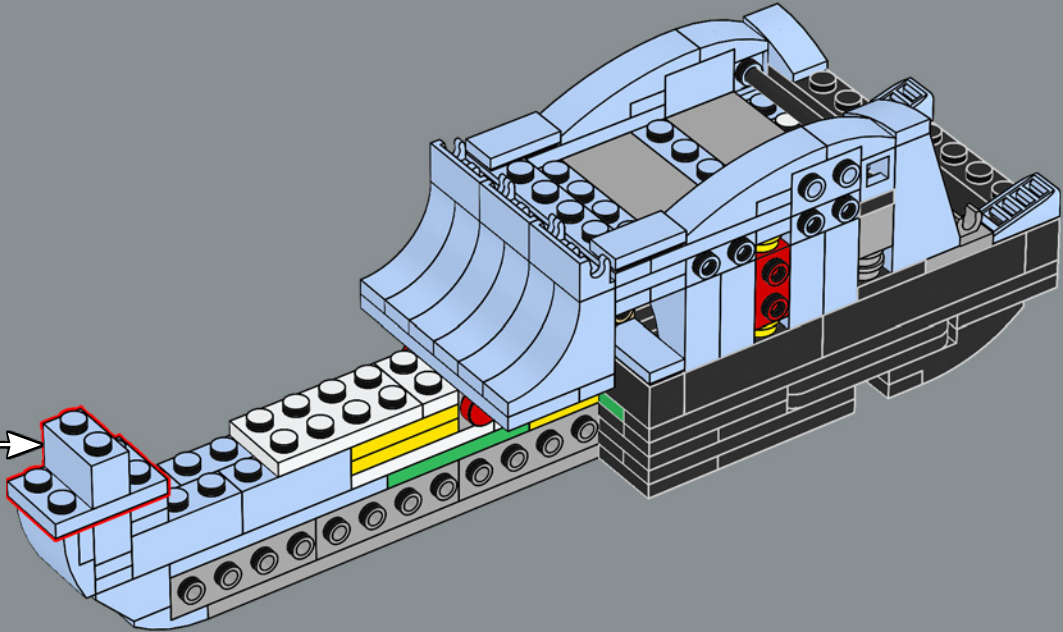
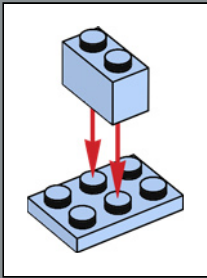

35

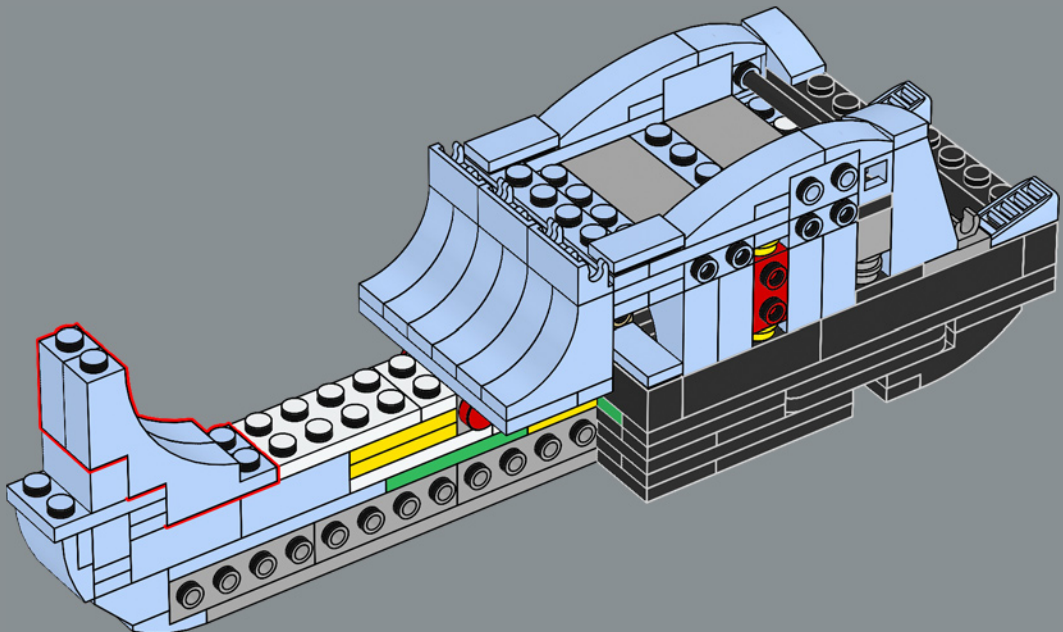

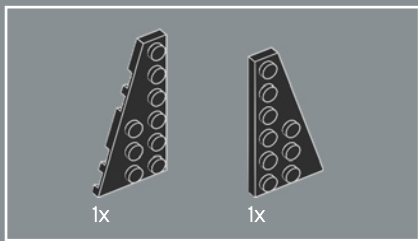

36

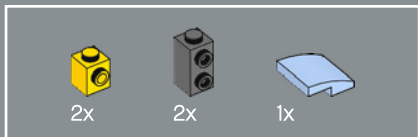
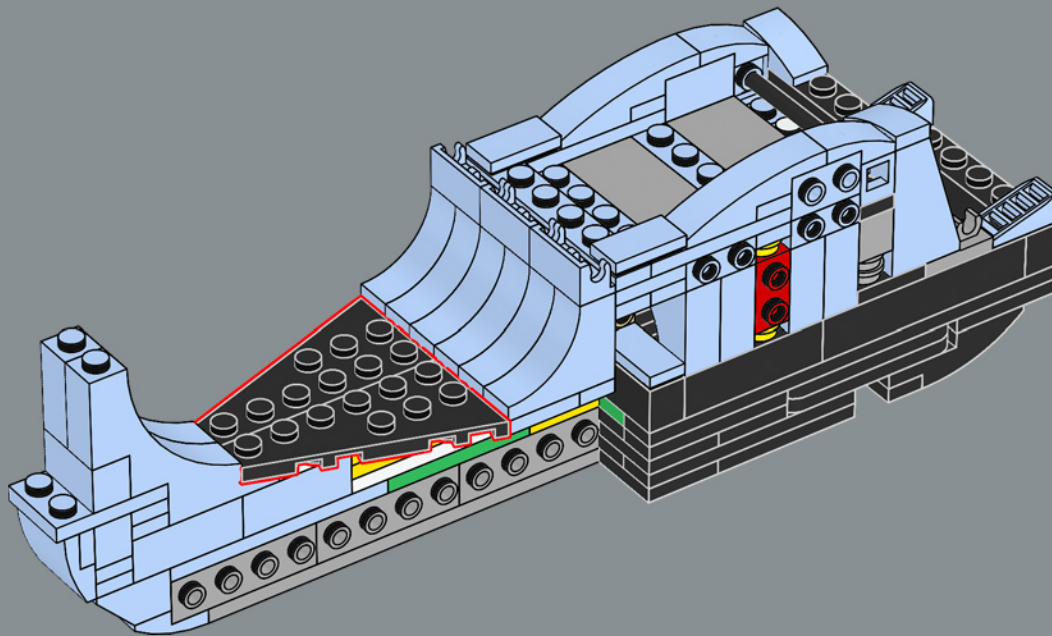

37

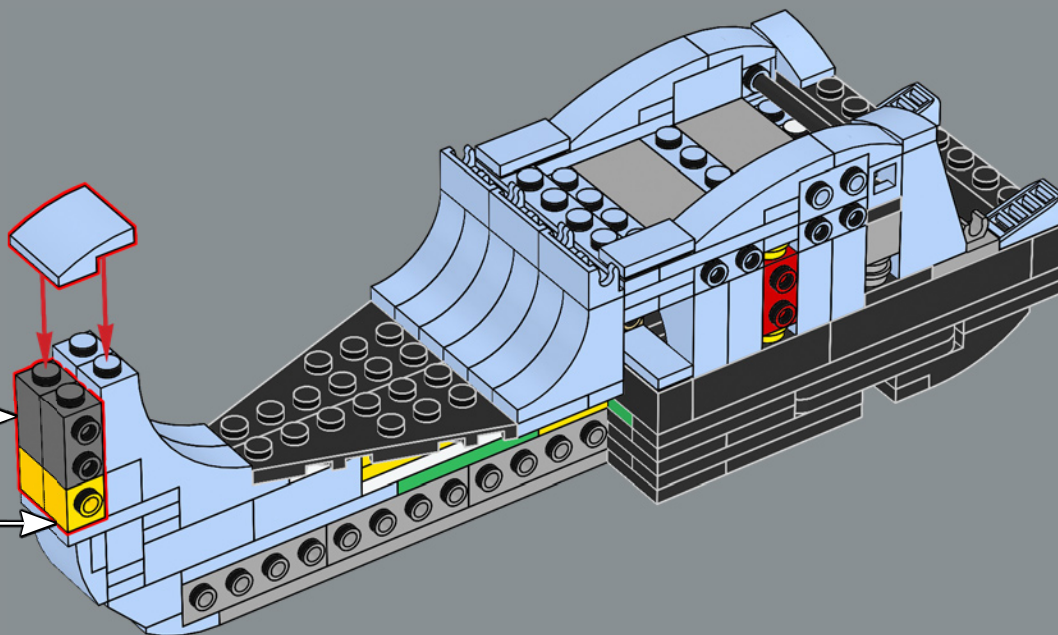
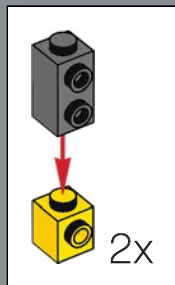

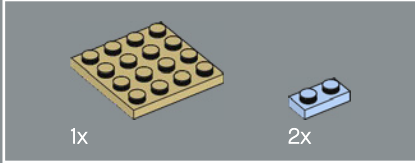
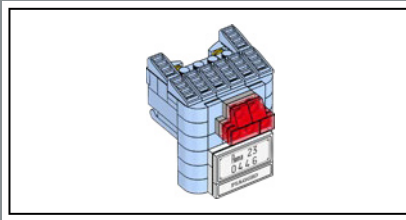
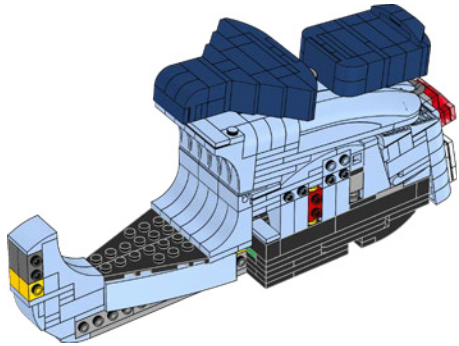
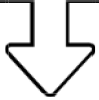

38

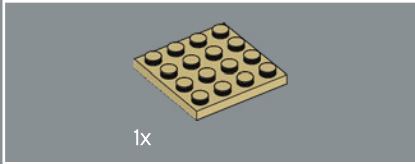
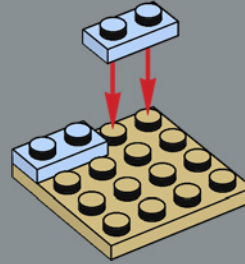

39

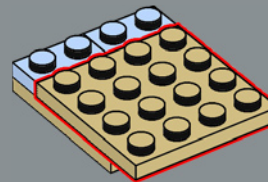

As of 2021, a total of 19 million Vespa scooters have been produced.

En 2021, Vespa franchit le palier des 19 millions de scooters produits depuis sa création.

Hasta 2021, se han fabricado 19 millones de escúteres Vespa.



40

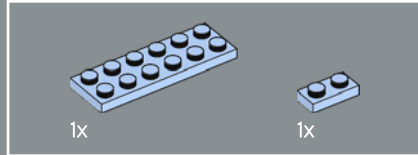
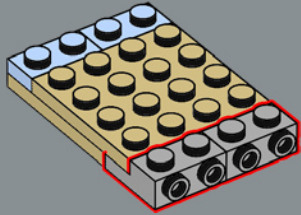

41

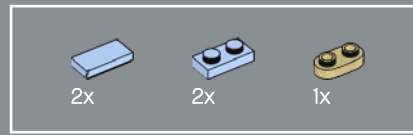
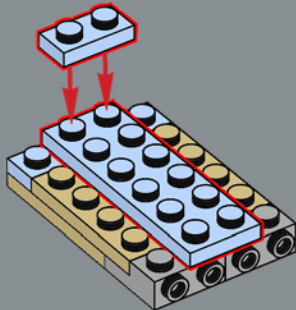

42

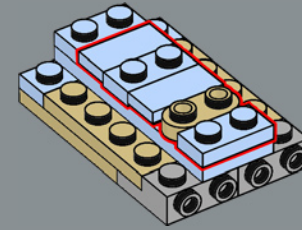

43

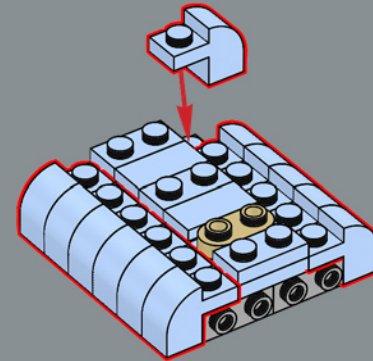

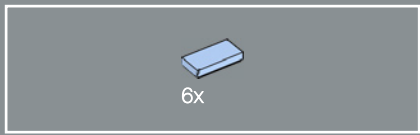

44

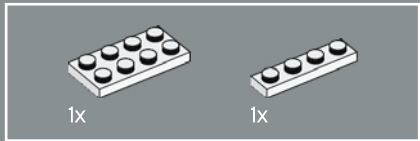
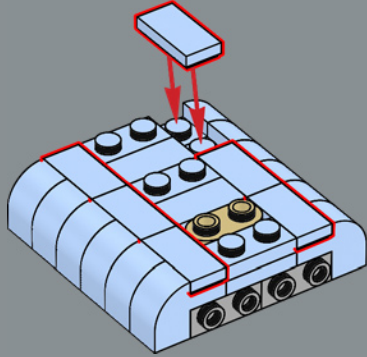

45

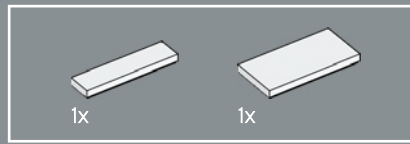
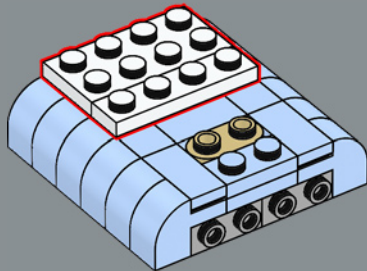

46

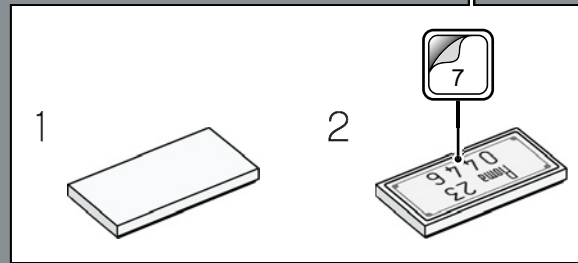
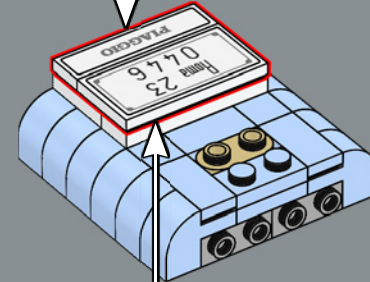
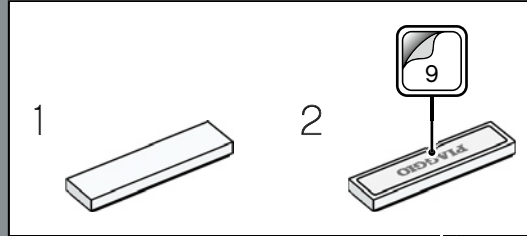

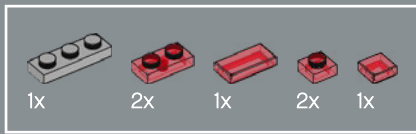

47

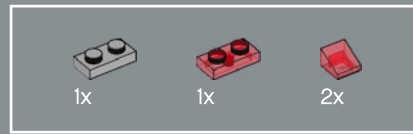
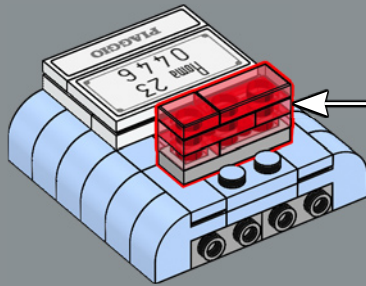
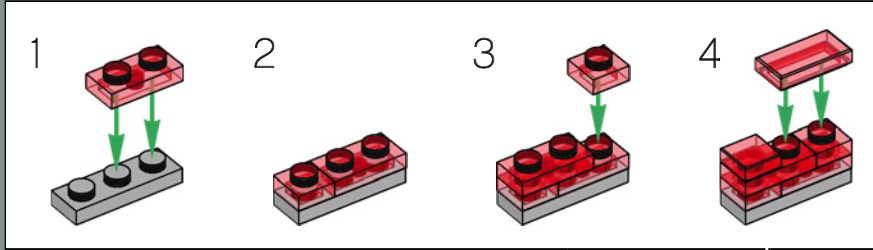

48

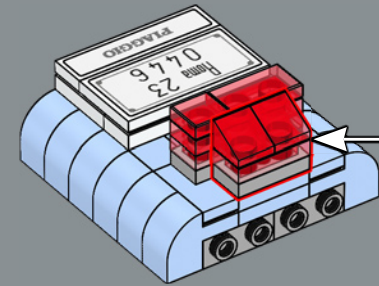
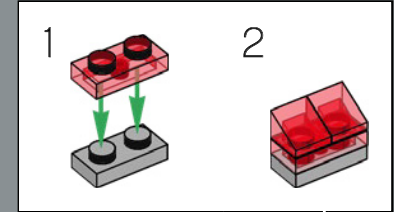

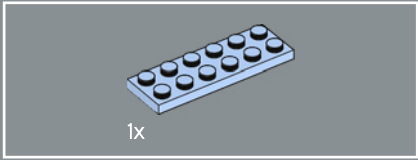
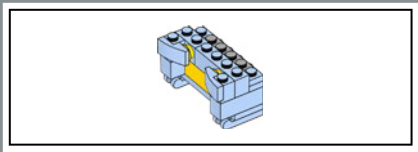

49

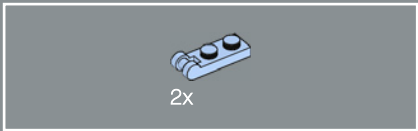
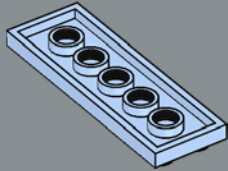

50

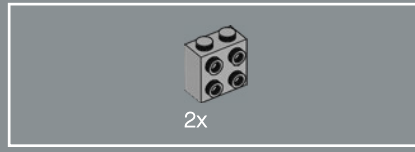
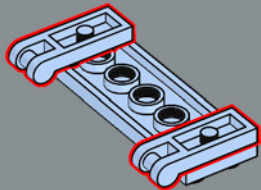

51

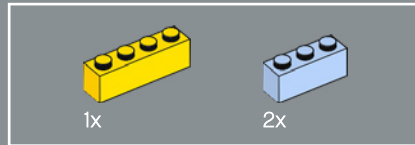
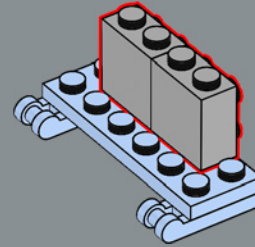

52

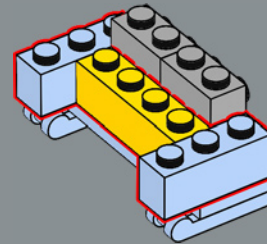



53

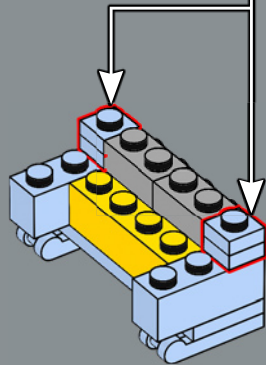
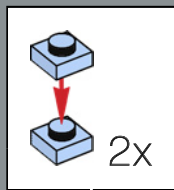

55

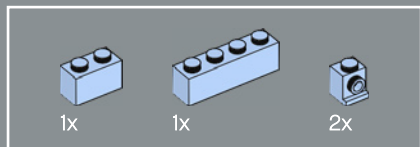
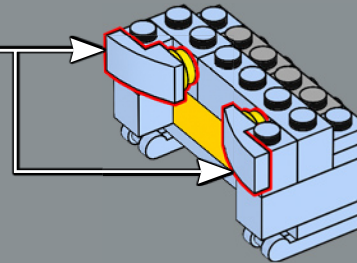
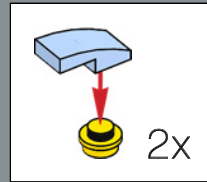

54

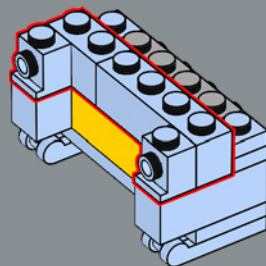

56

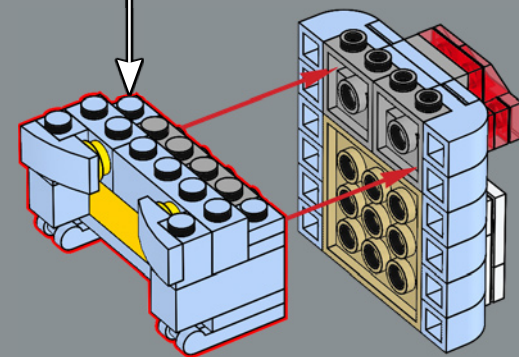



8x

57

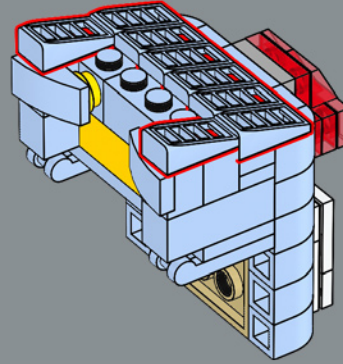

58

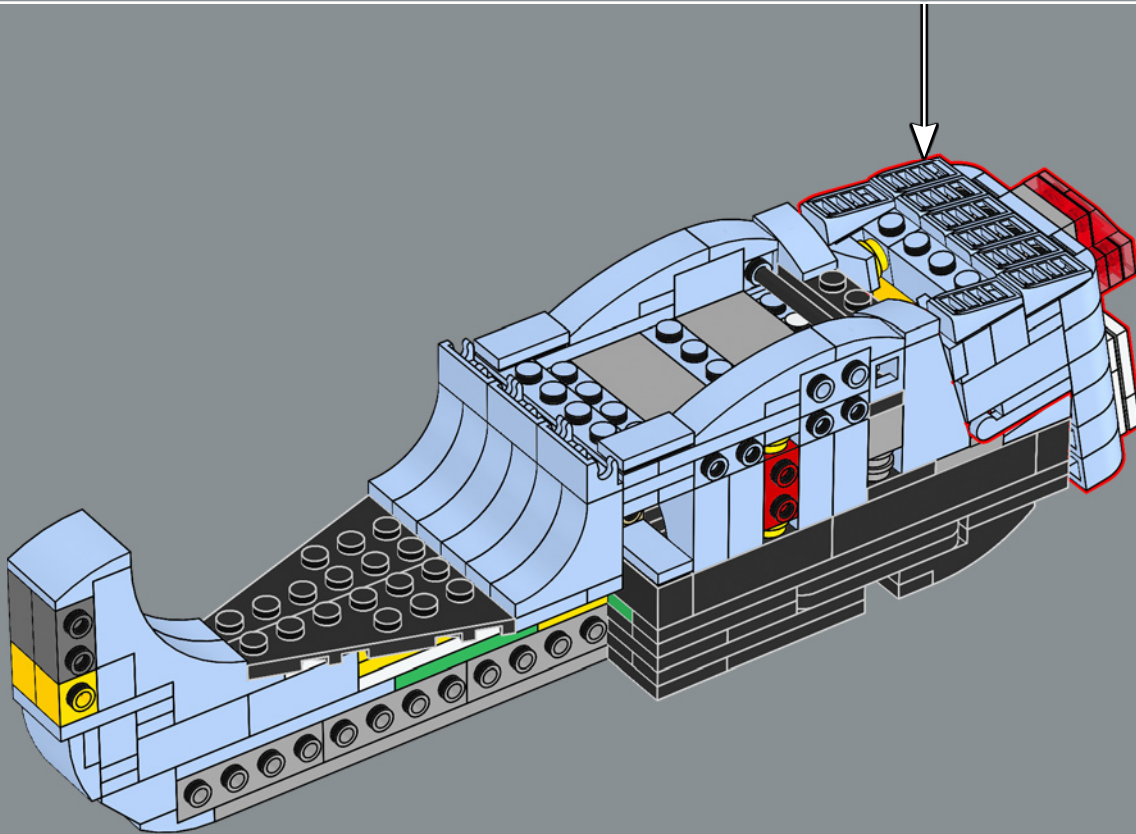

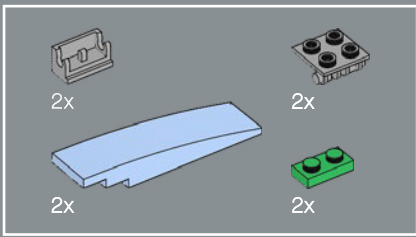

59

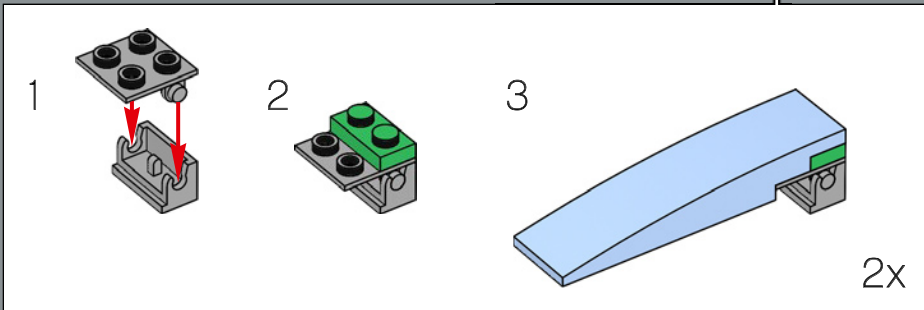
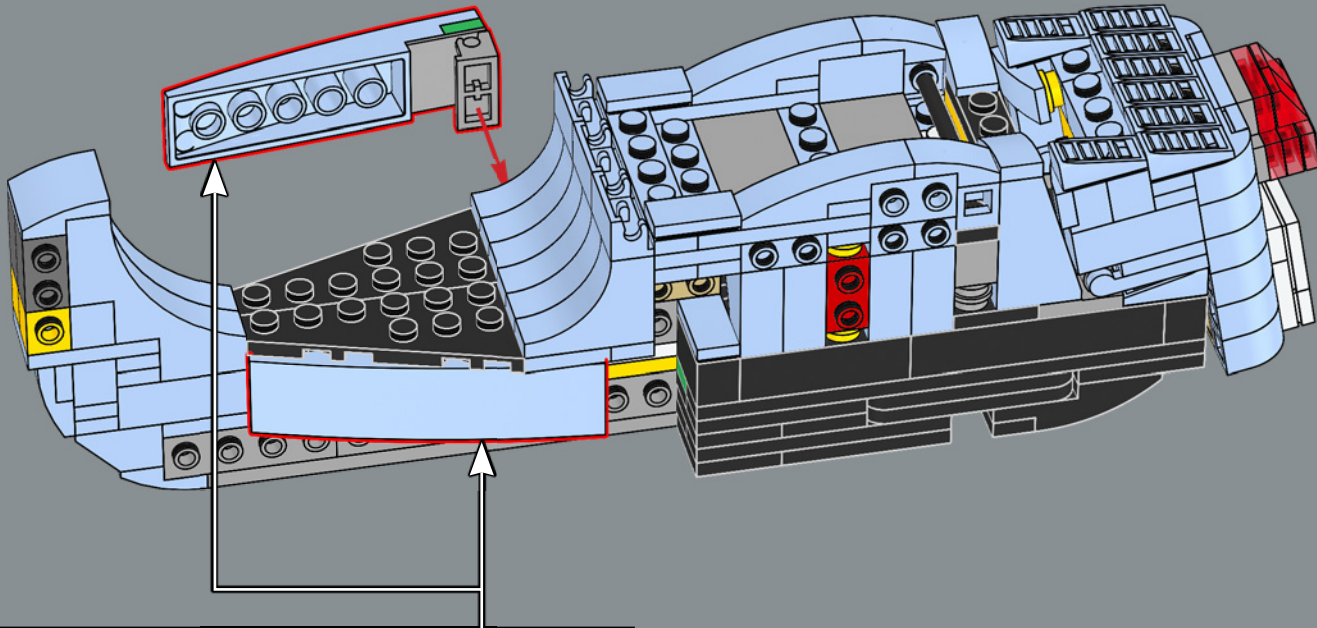

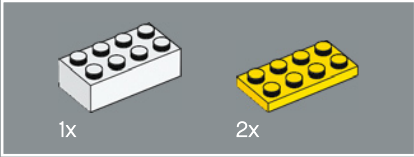
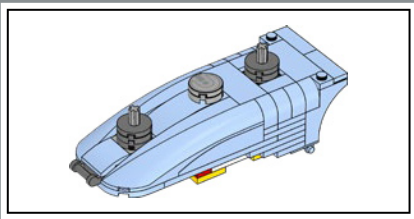

60

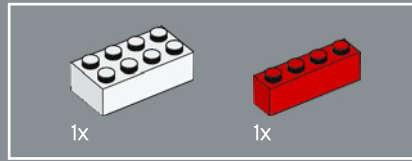
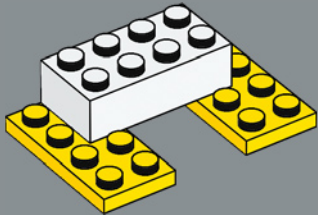

61

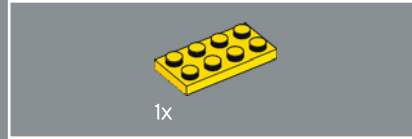
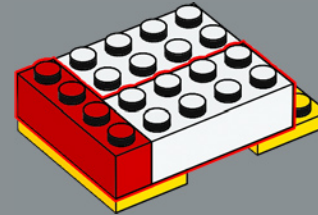

62

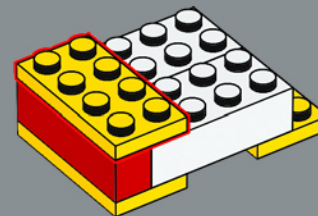

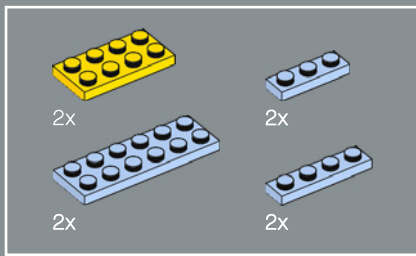

63

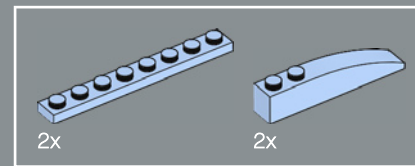
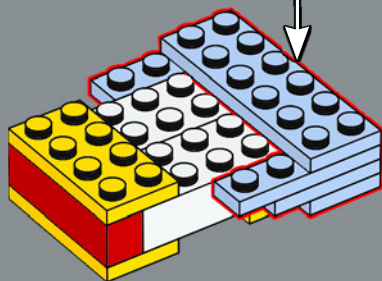
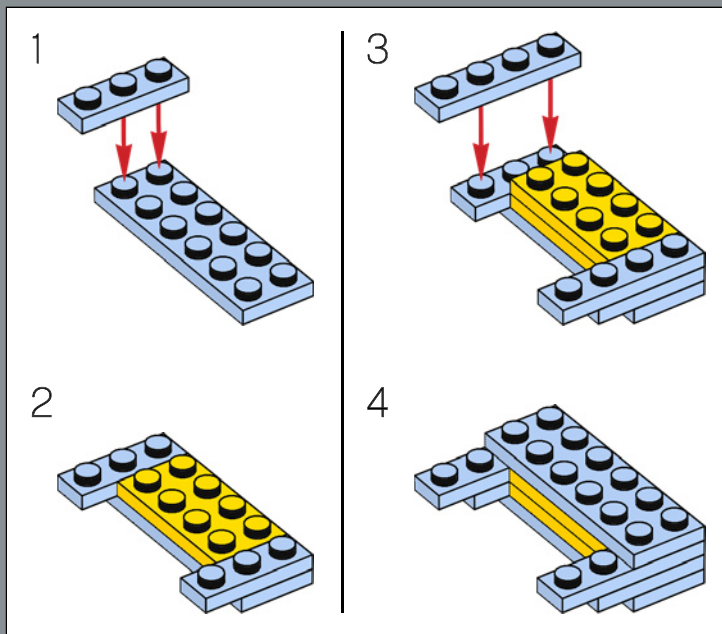

64

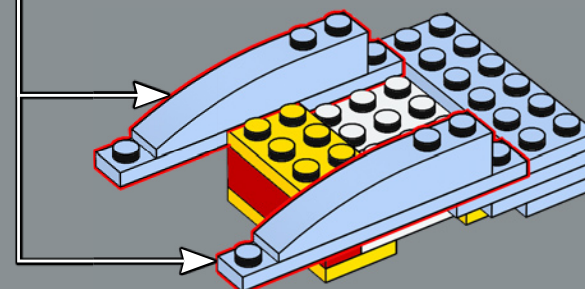
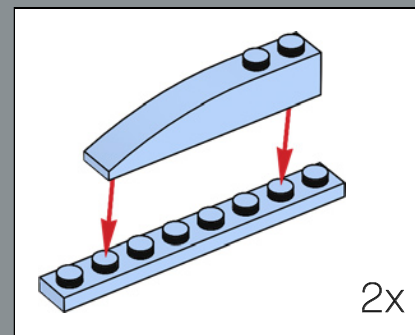

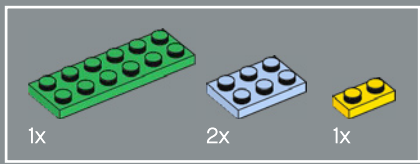

65

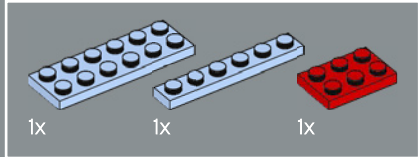
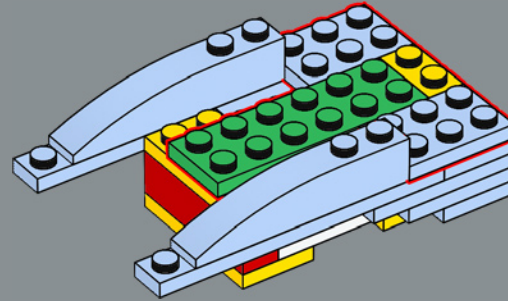

66

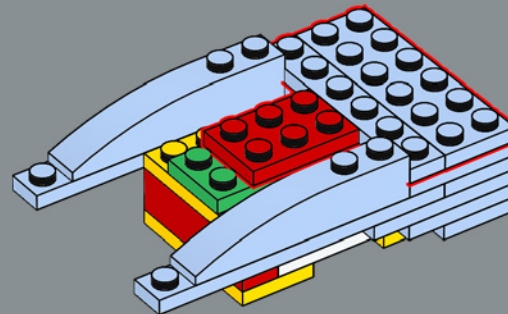

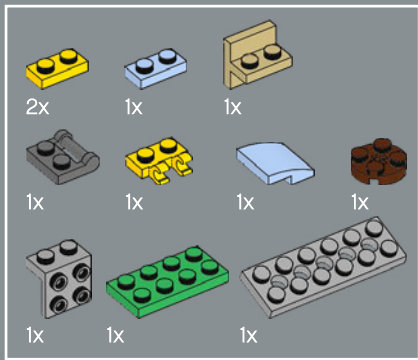

67

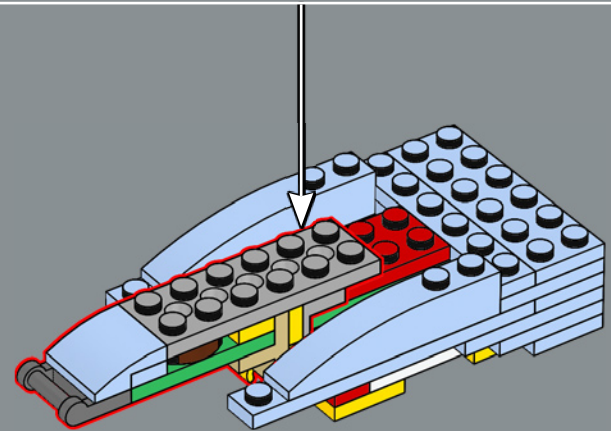
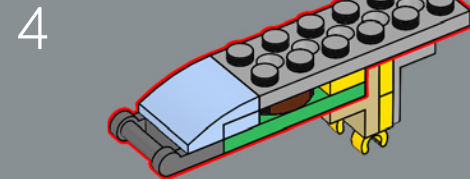
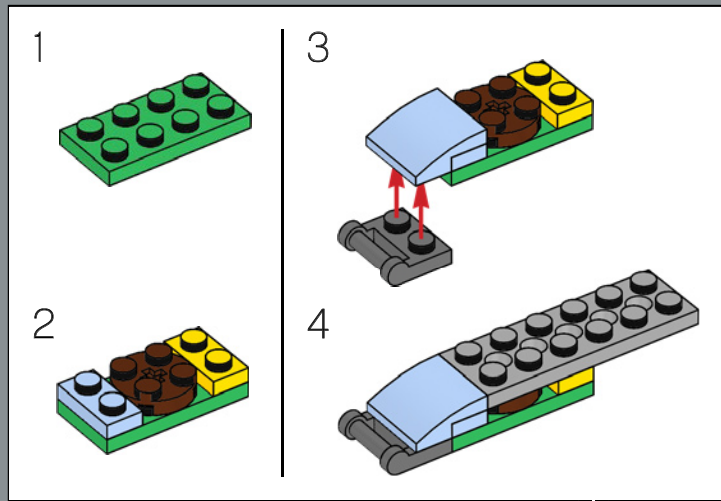
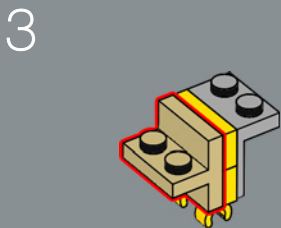
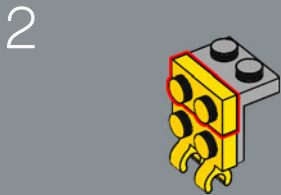
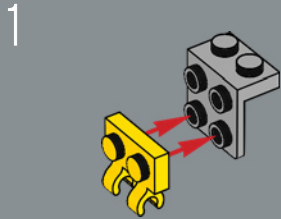

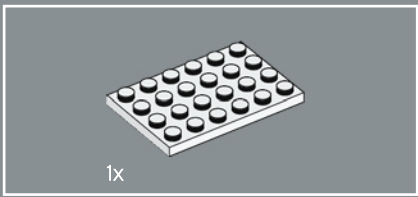

68

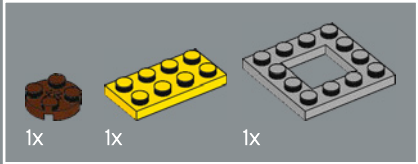
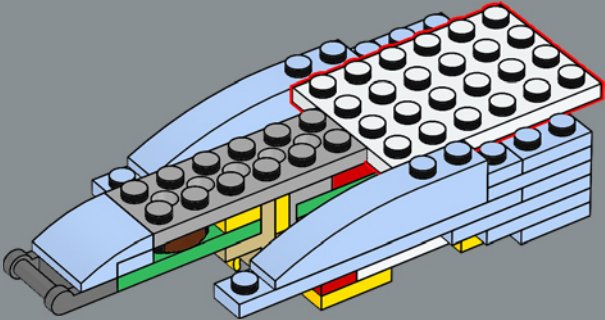

69

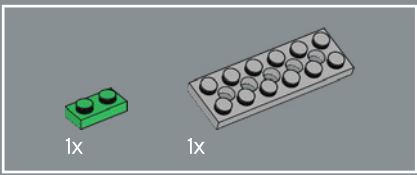
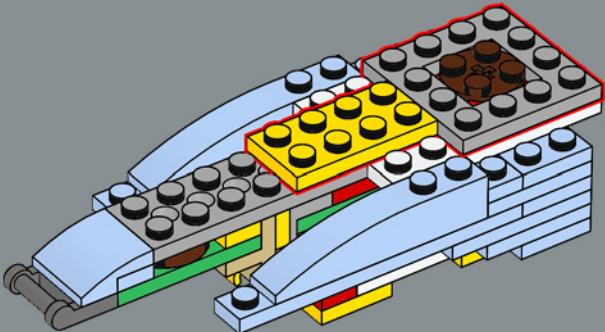

70

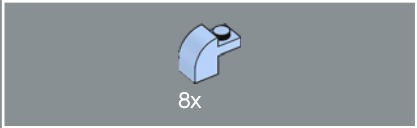
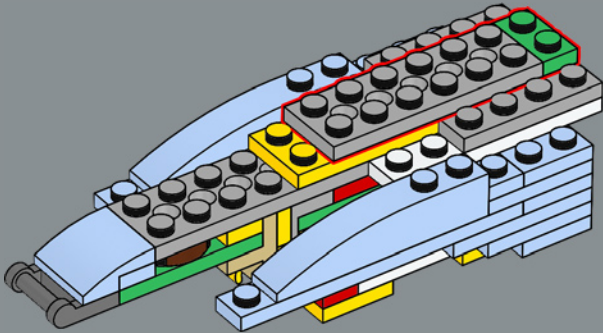

71

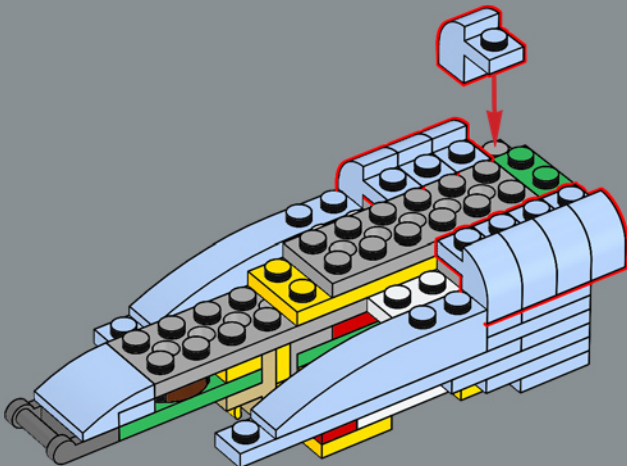

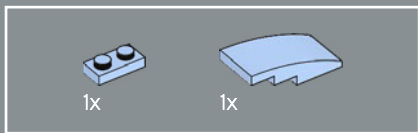

72

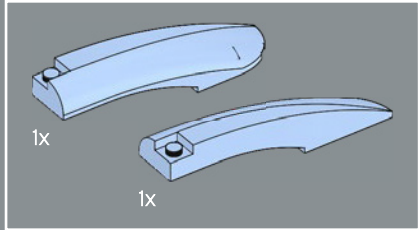
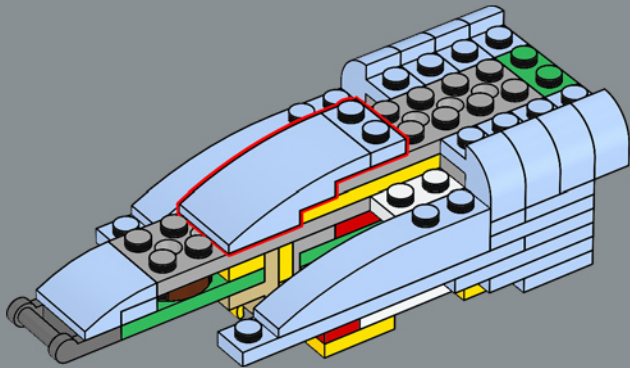

73

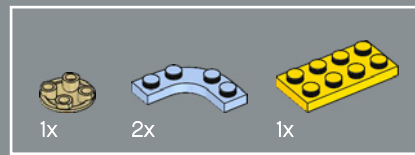
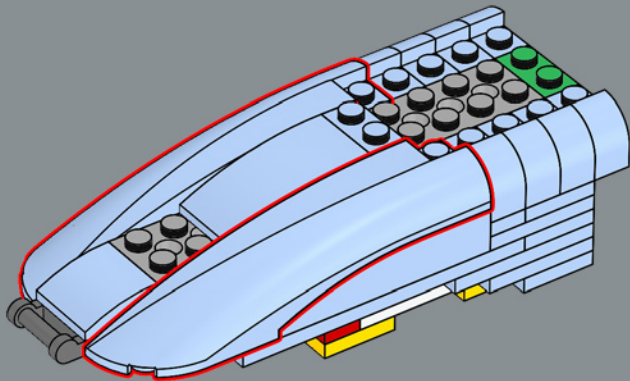

74

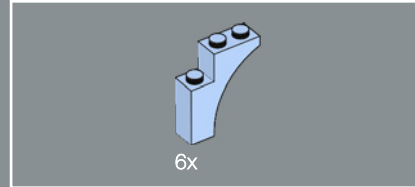
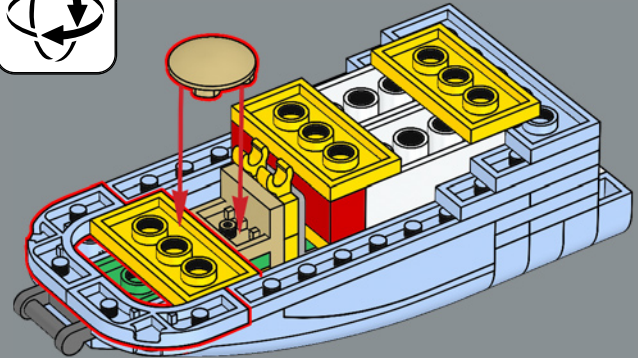

75

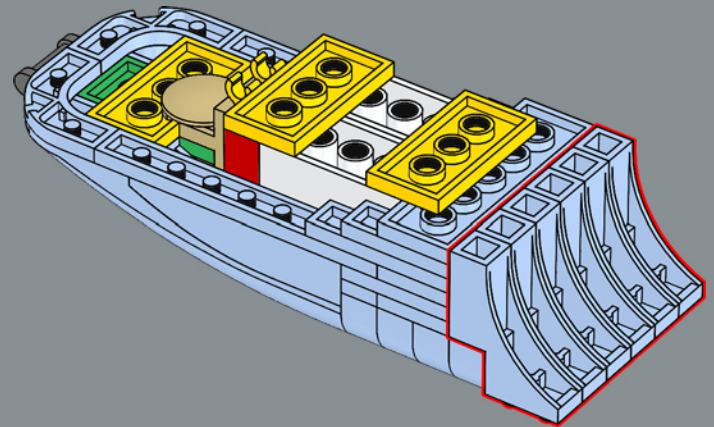

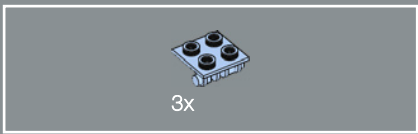

76

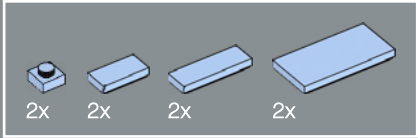
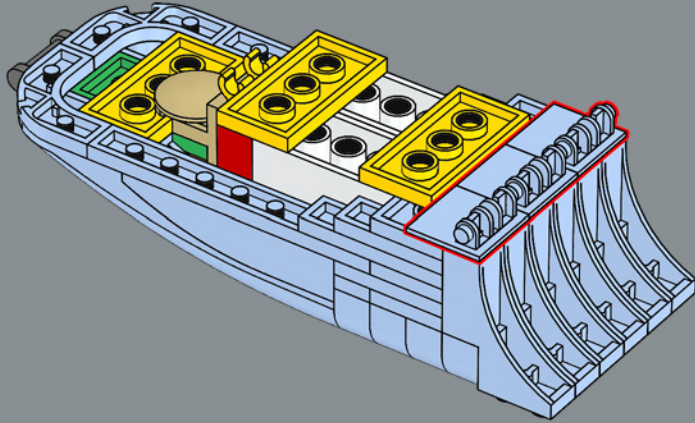

77

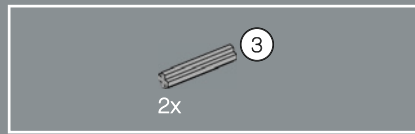
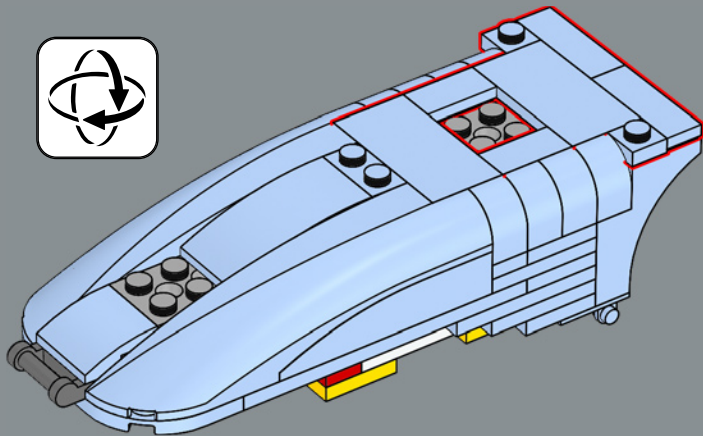

78

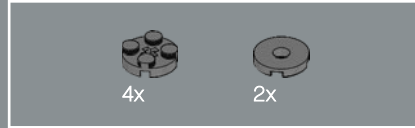
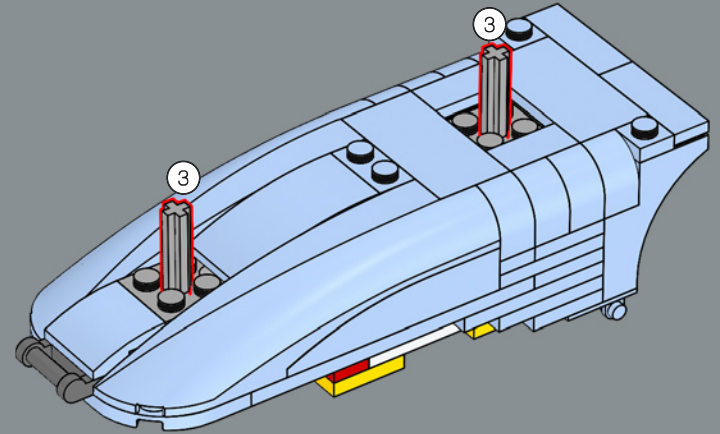

79

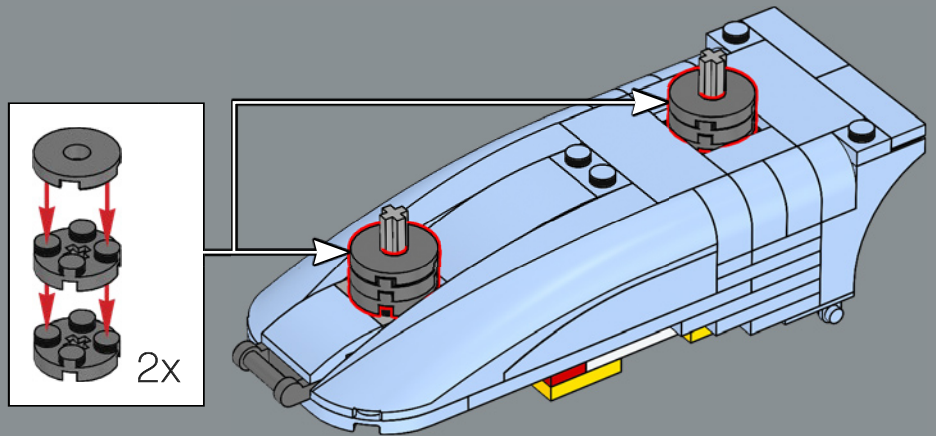

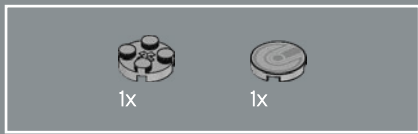

80

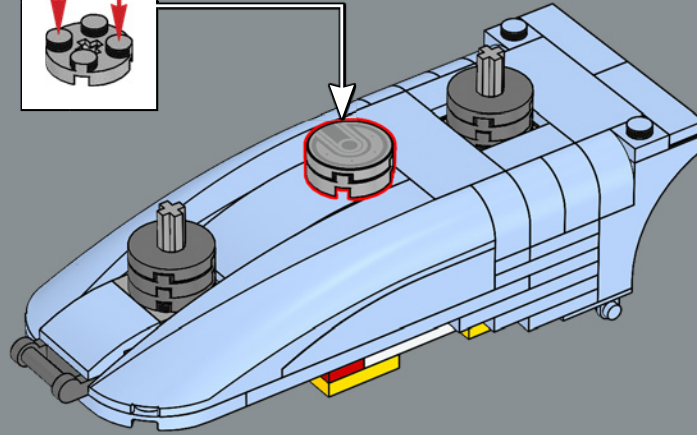
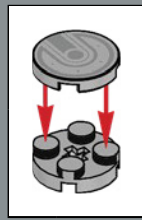

81

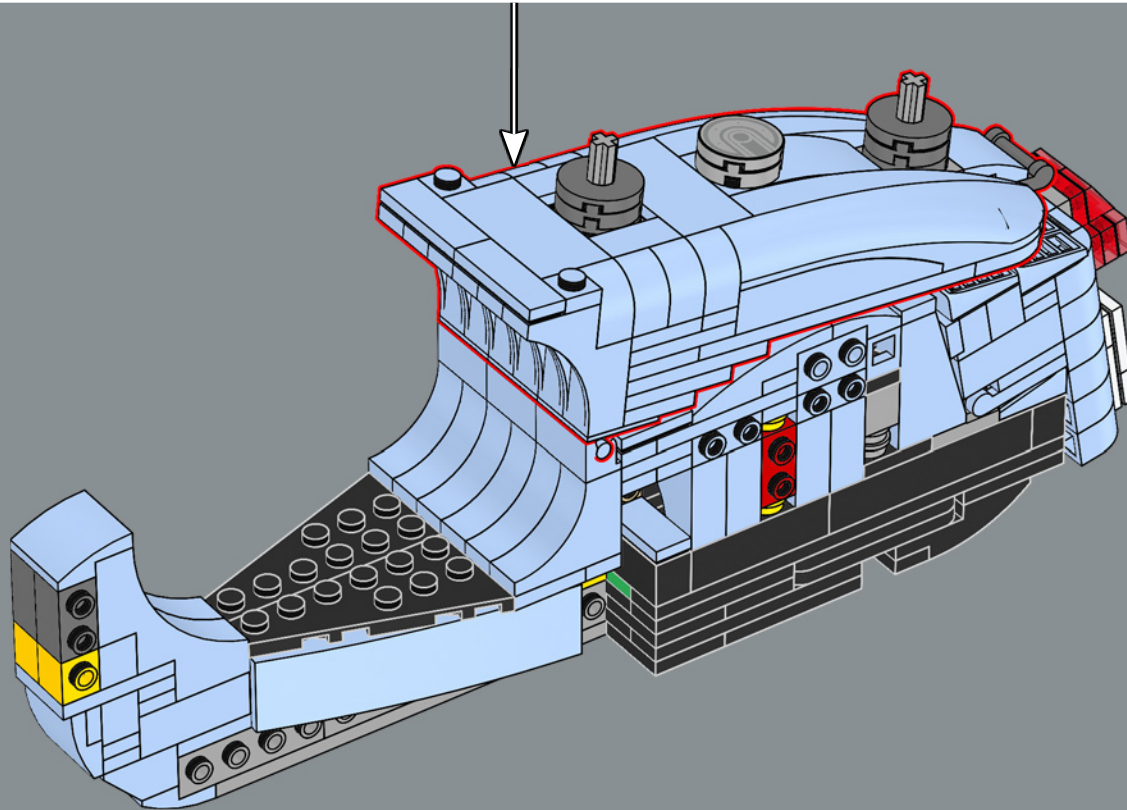

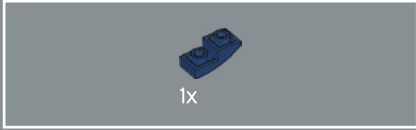
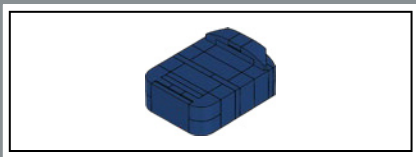

82

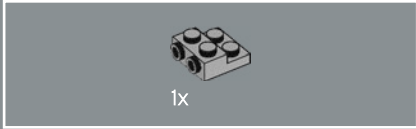
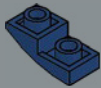

83

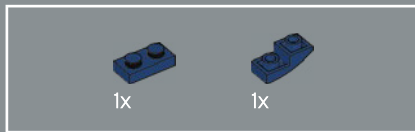

84

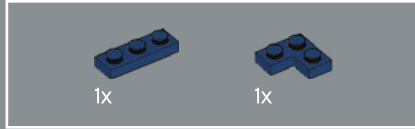
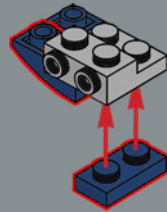

85

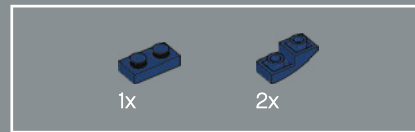
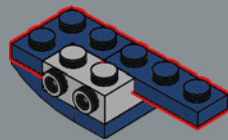

86

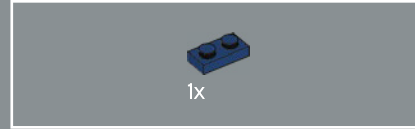
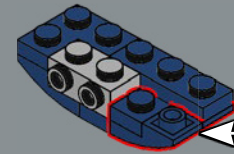
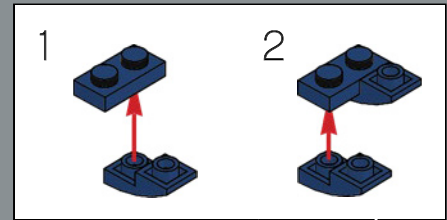

87

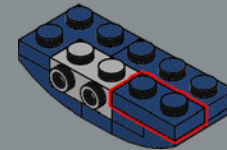

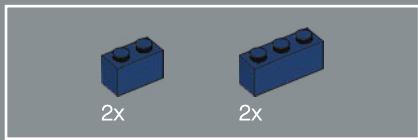

88

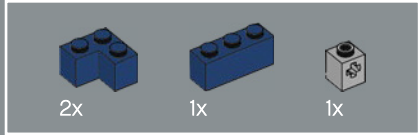
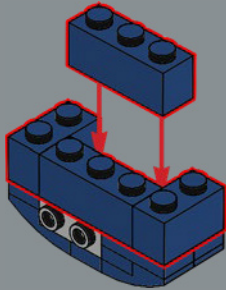

89

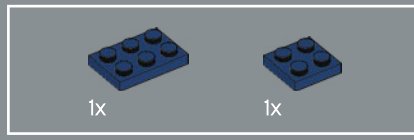
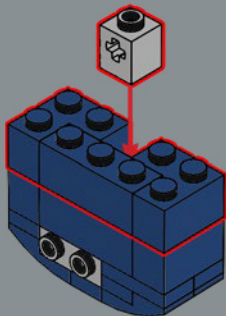

90

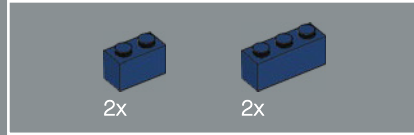
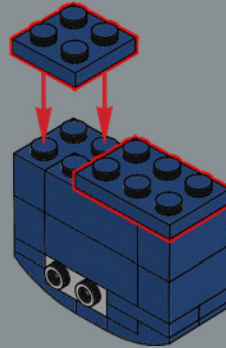

91

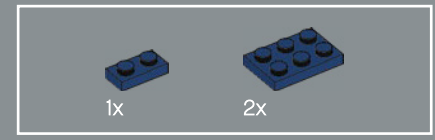
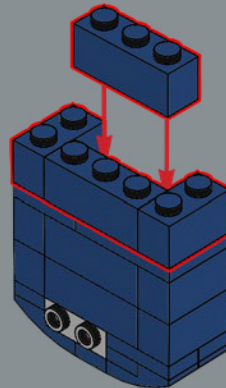

92

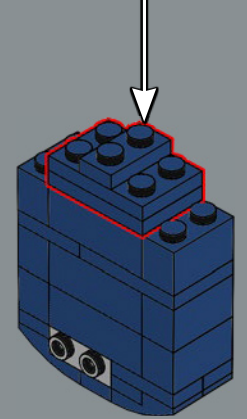
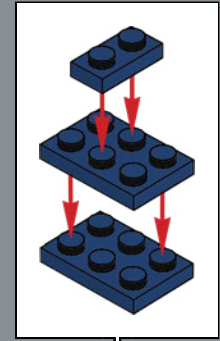



4x

93

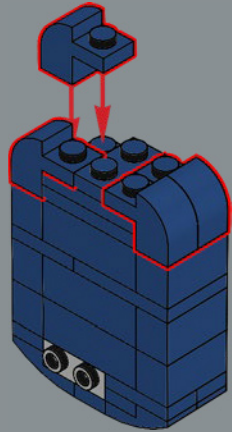

1x

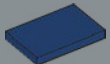

1x

94

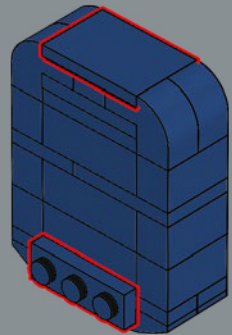

1x



1x



1x

95

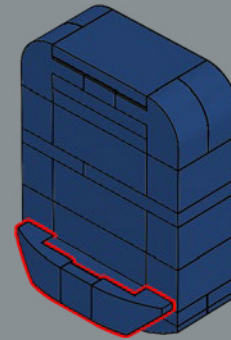

96

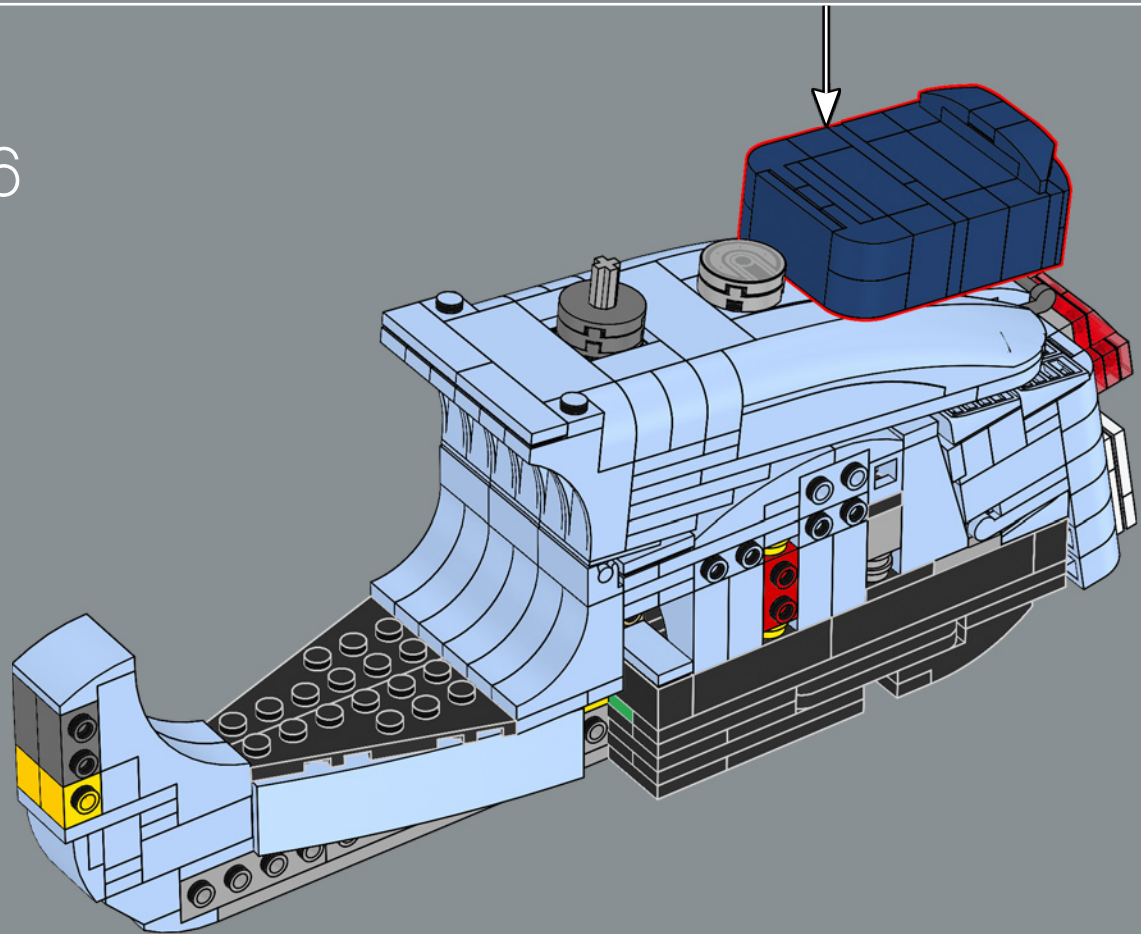

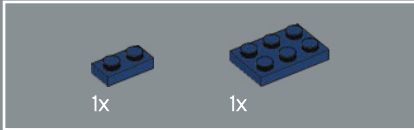
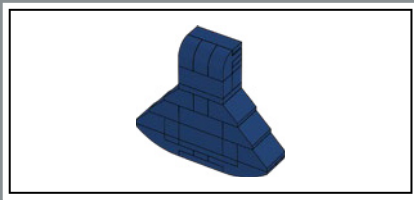

97

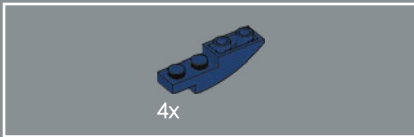
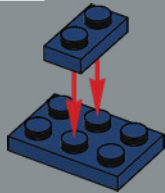

98

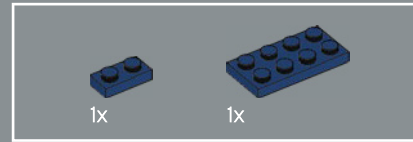
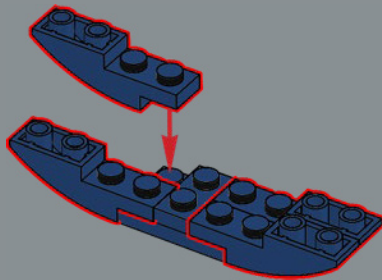

99

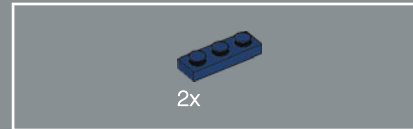
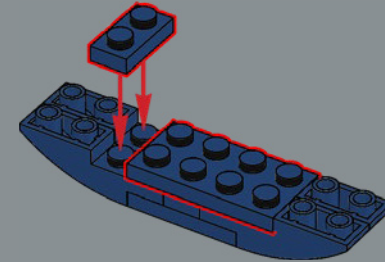

100

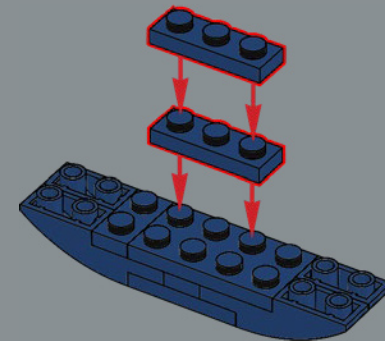

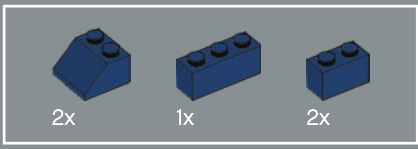

101

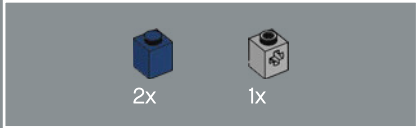
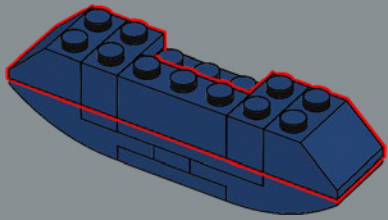

102

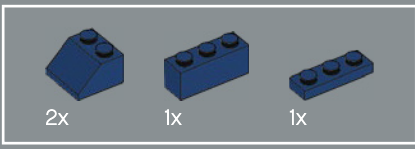
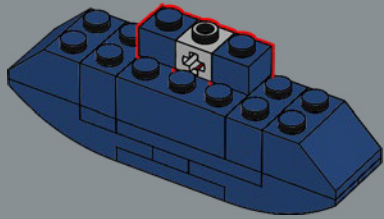

103

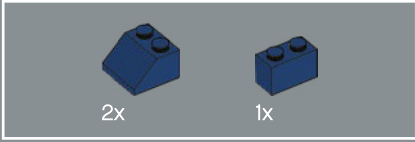
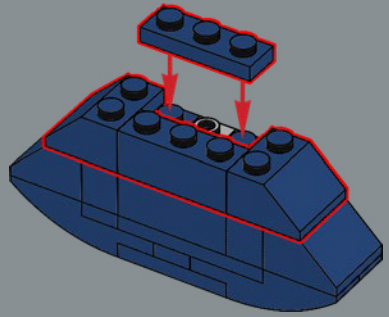

104

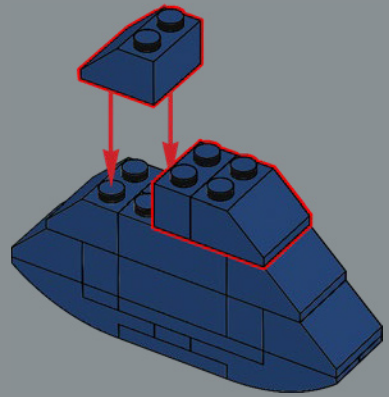

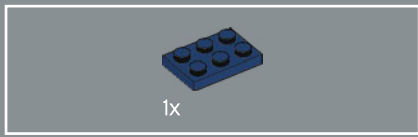

105

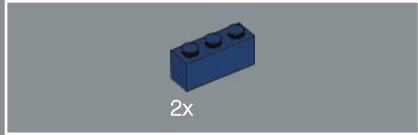
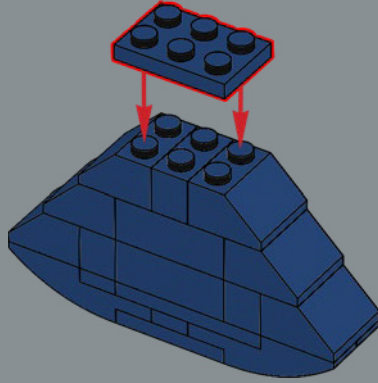

106

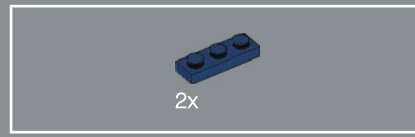
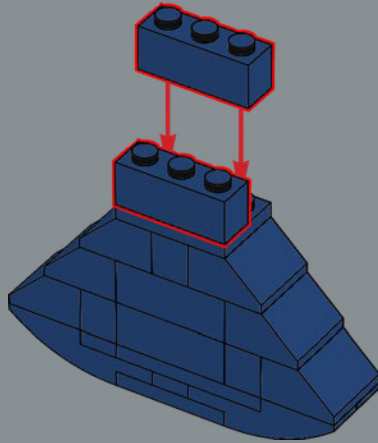

107

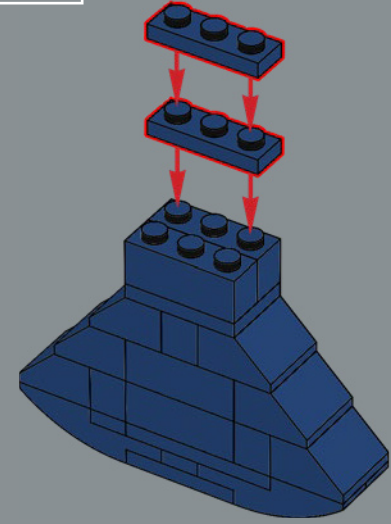

108

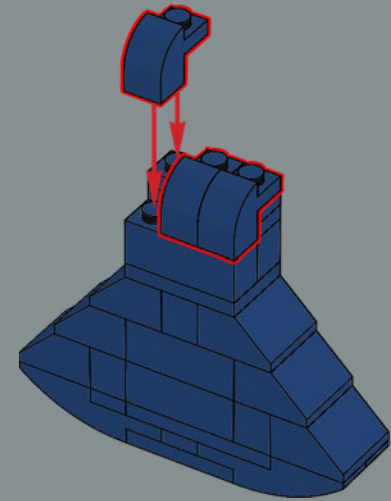

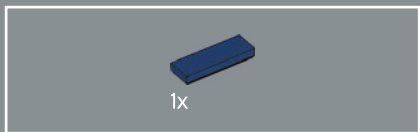

109

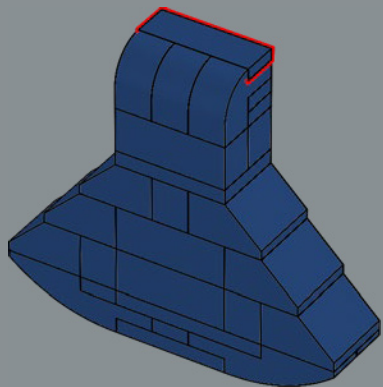

110

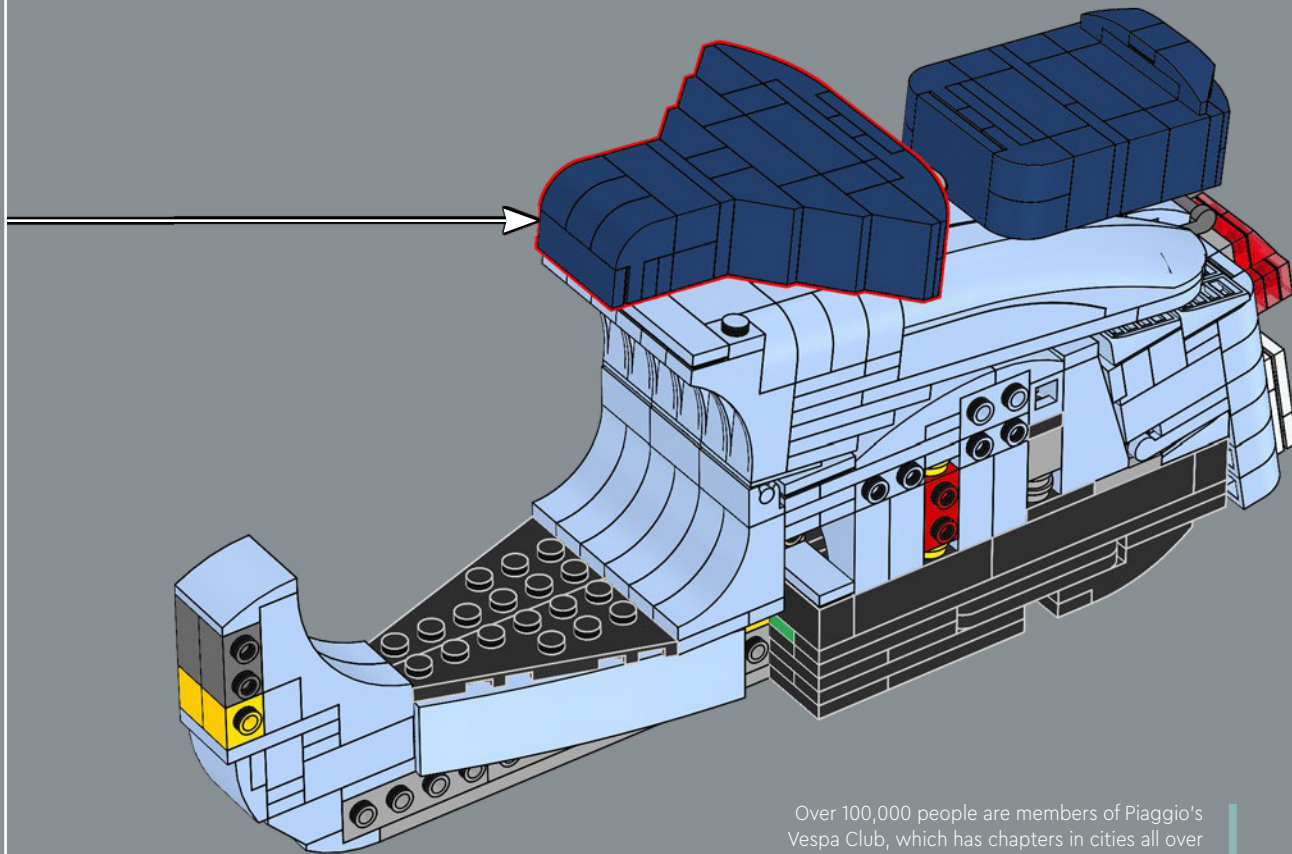

Over 100,000 people are members of Piaggio's Vespa Club, which has chapters in cities all over the world.

Plus de 100 000 personnes sont membres du Club Vespa de Piaggio, qui a des branches aux quatre coins du monde.

Más de 100.000 personas pertenecen al Vespa Club de Piaggio, con presencia en numerosas ciudades de todo el mundo.

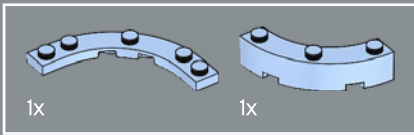
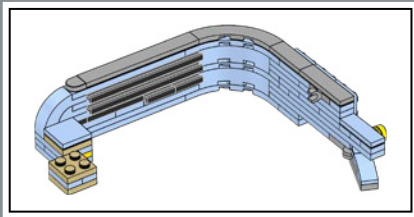
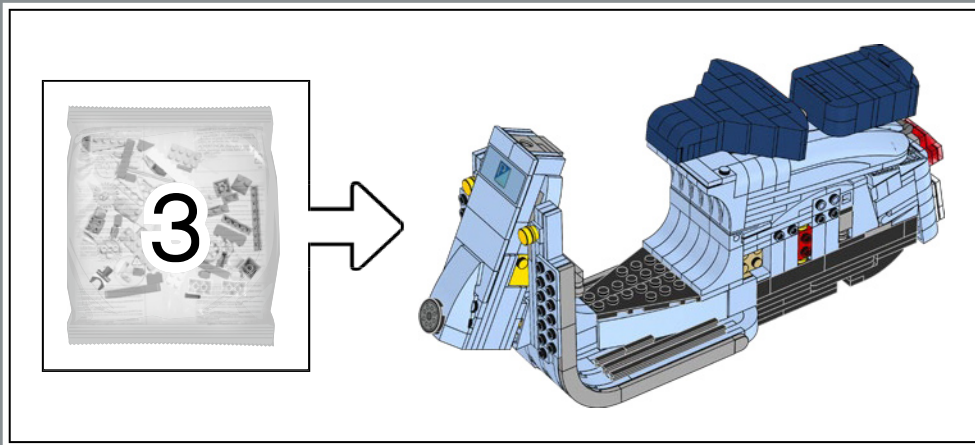

111

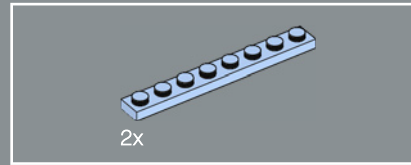
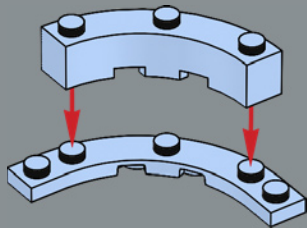

112

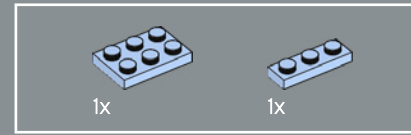
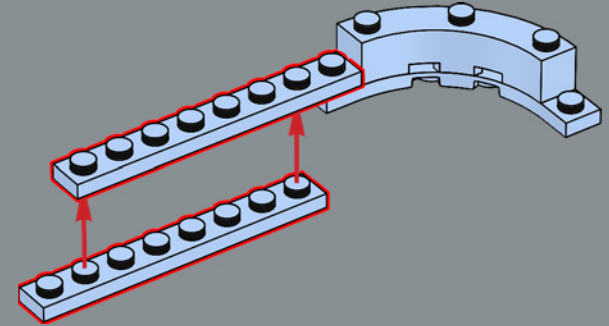

113

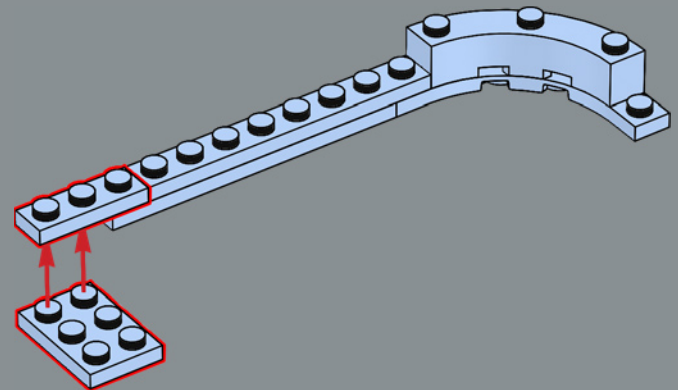

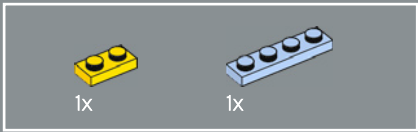

114

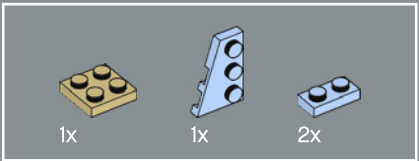
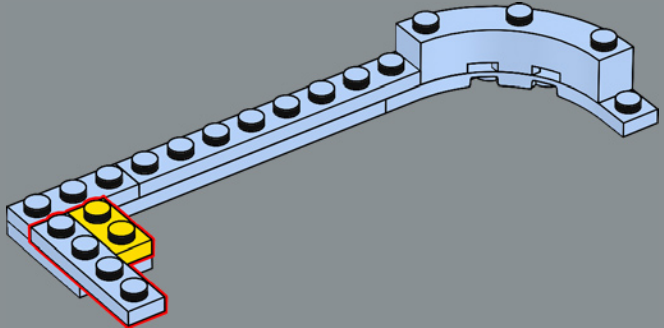

115

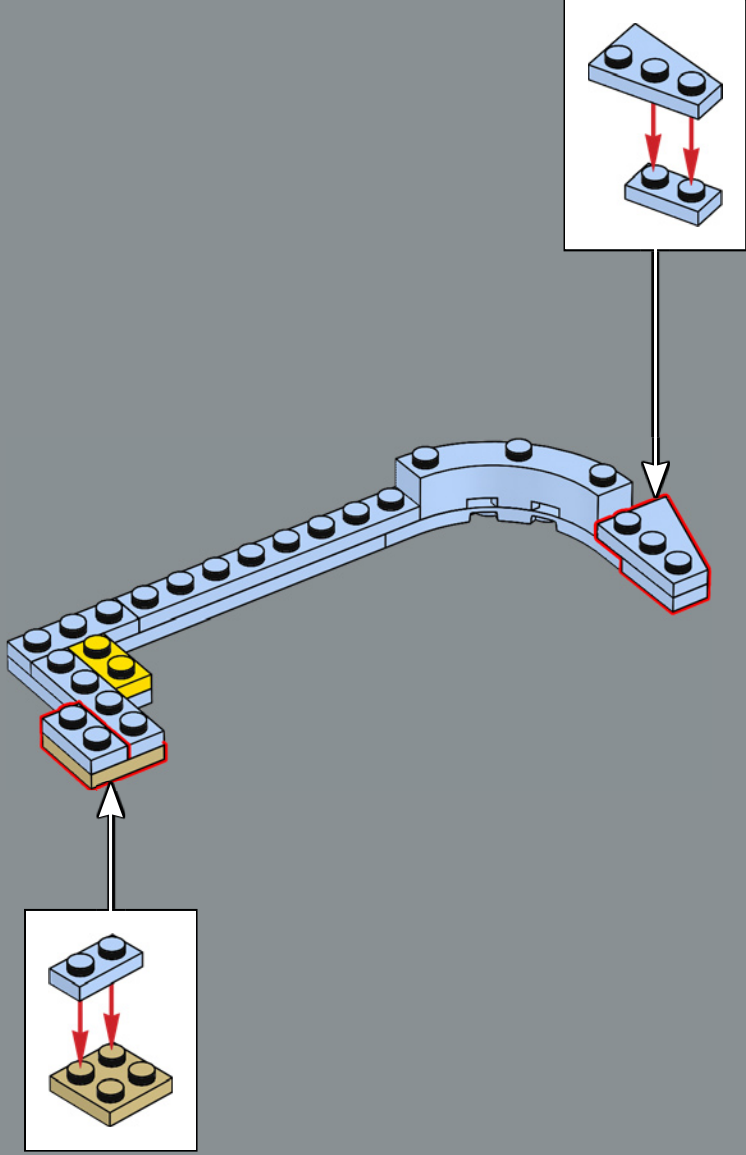

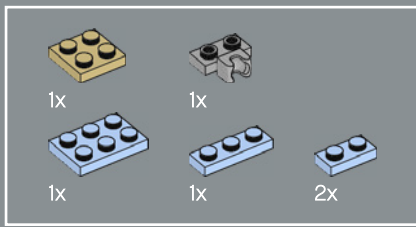

116

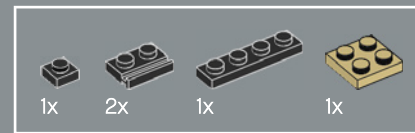
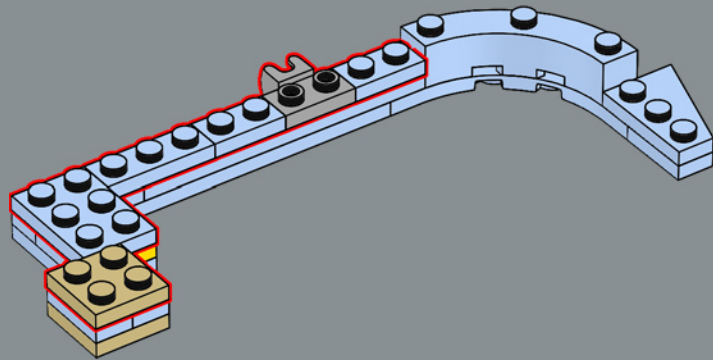

117

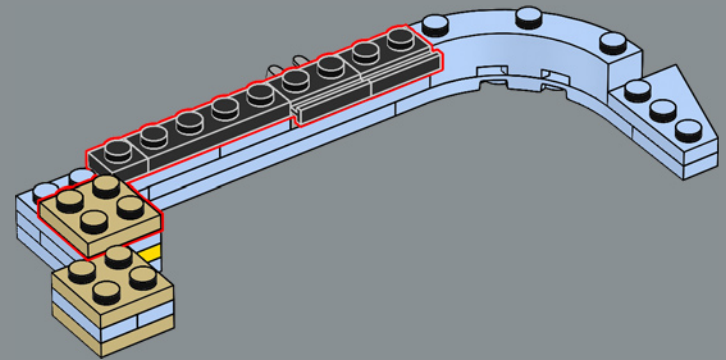

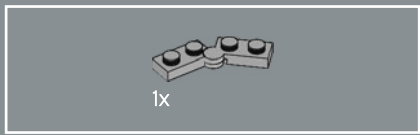

118

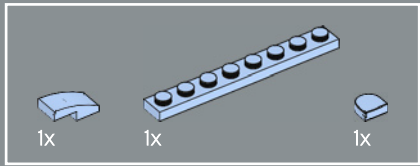
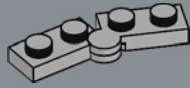

119

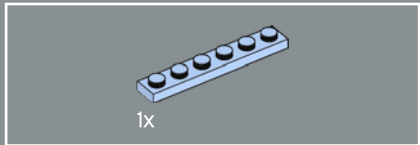
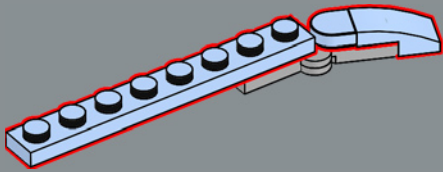

120

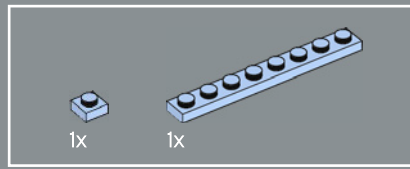
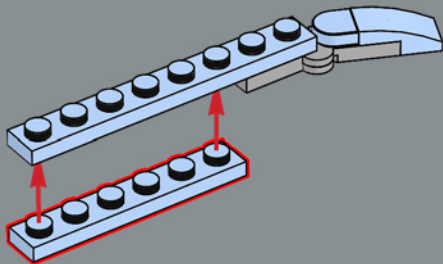

121

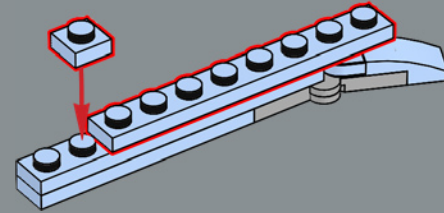

122

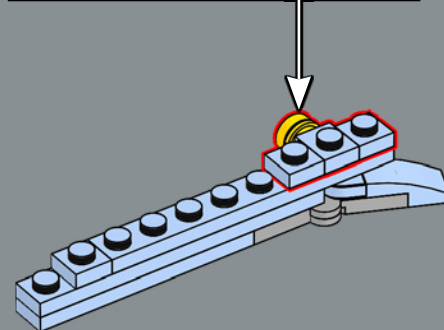
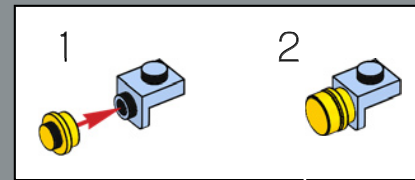



123

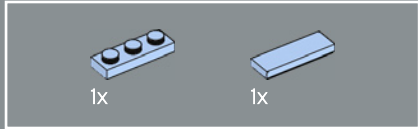
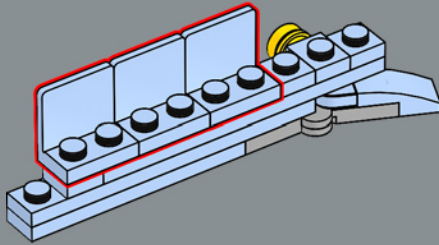

124

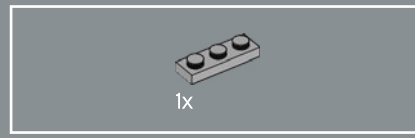
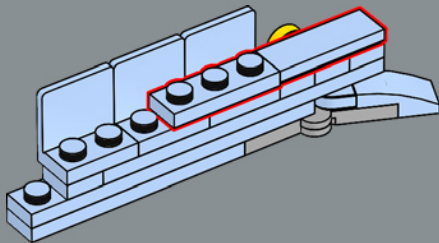

125

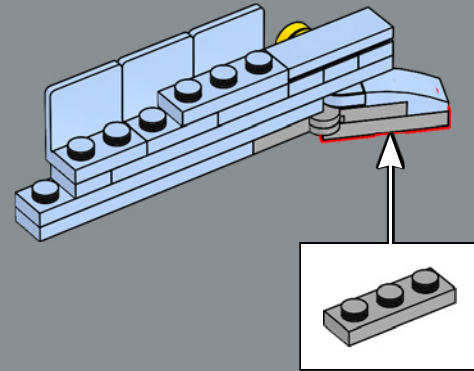

126

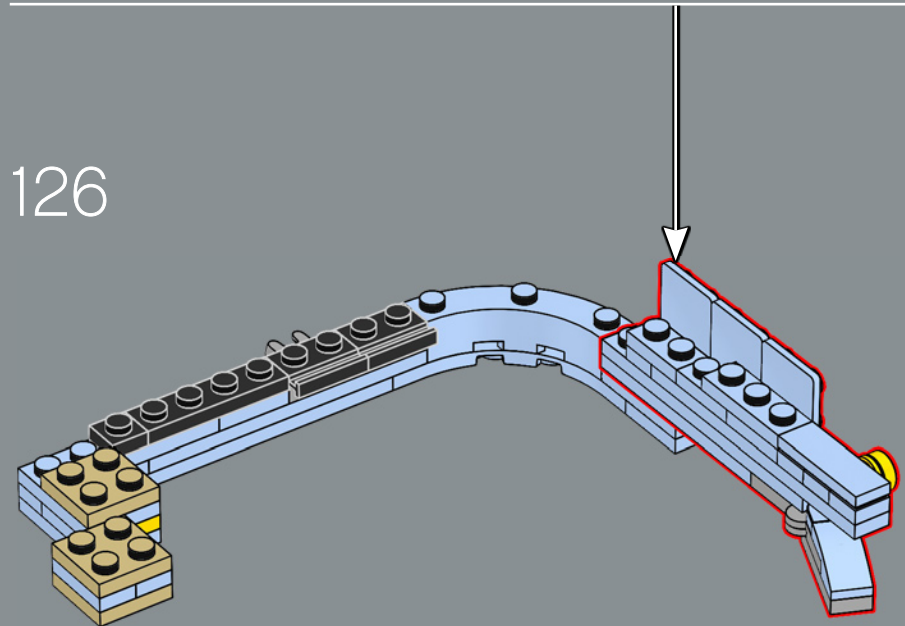

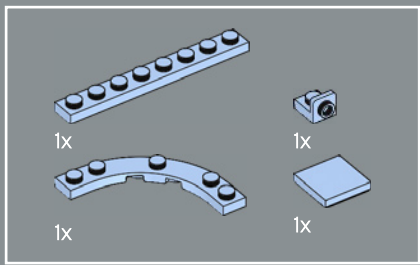

127

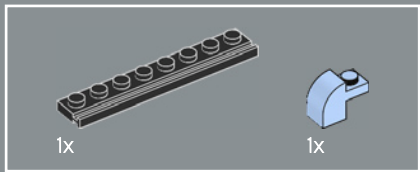
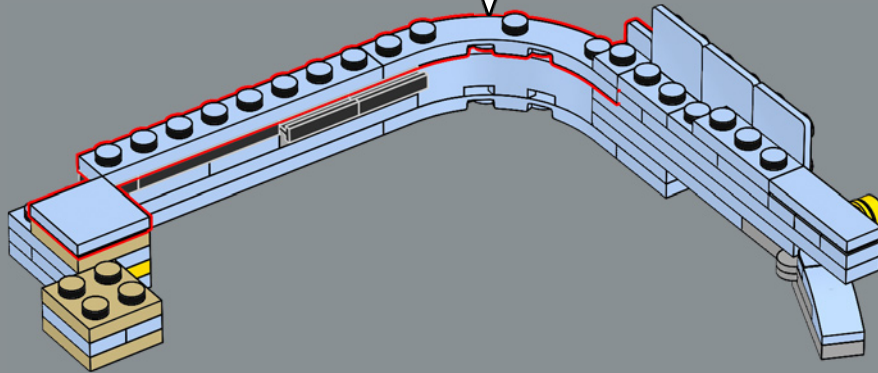
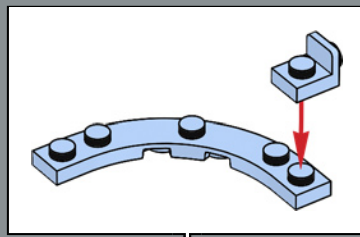

128

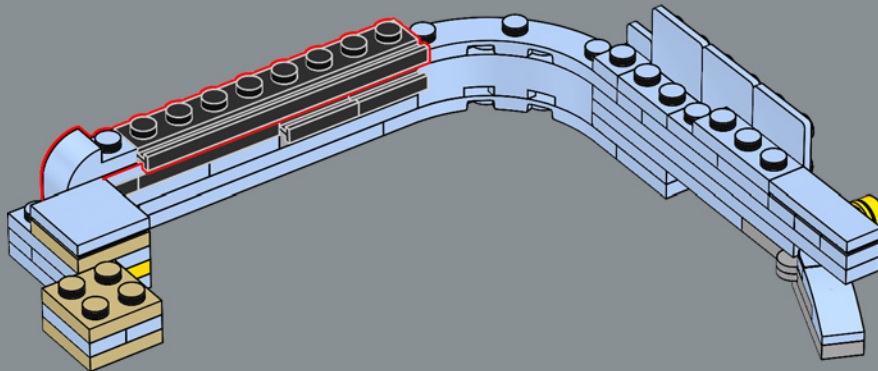

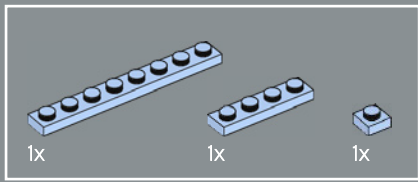

129

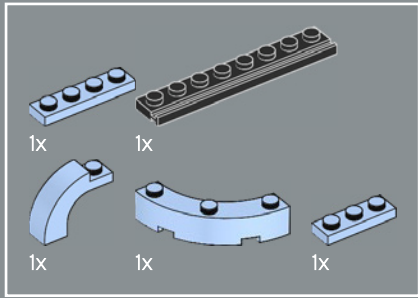
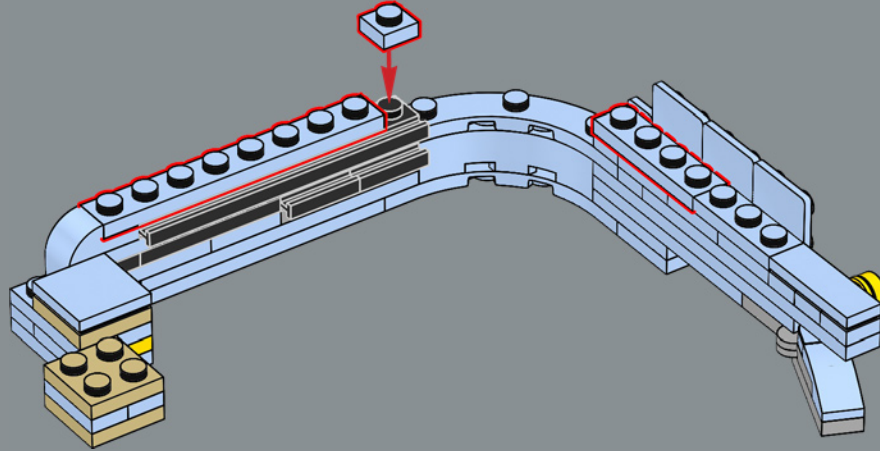

130

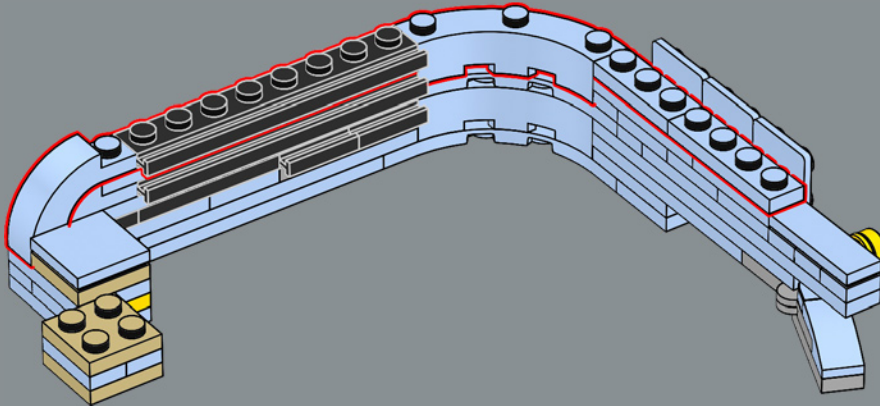

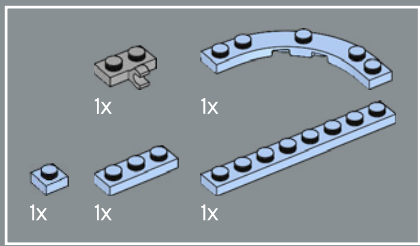

131

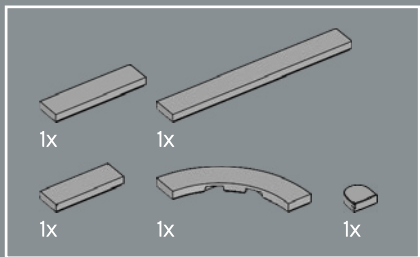
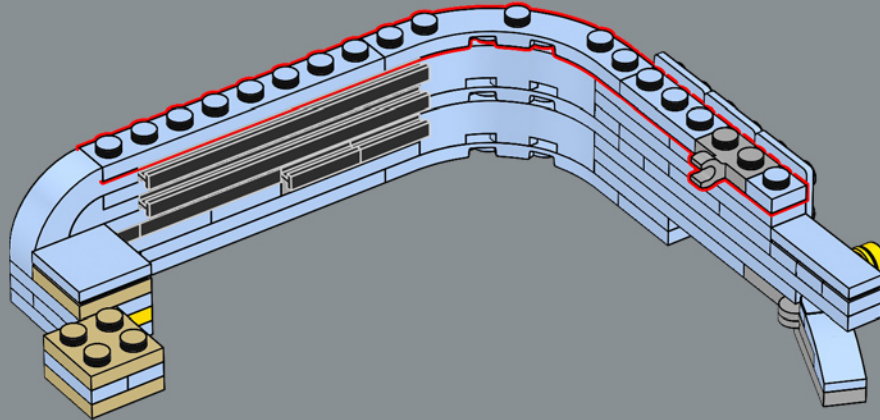

132

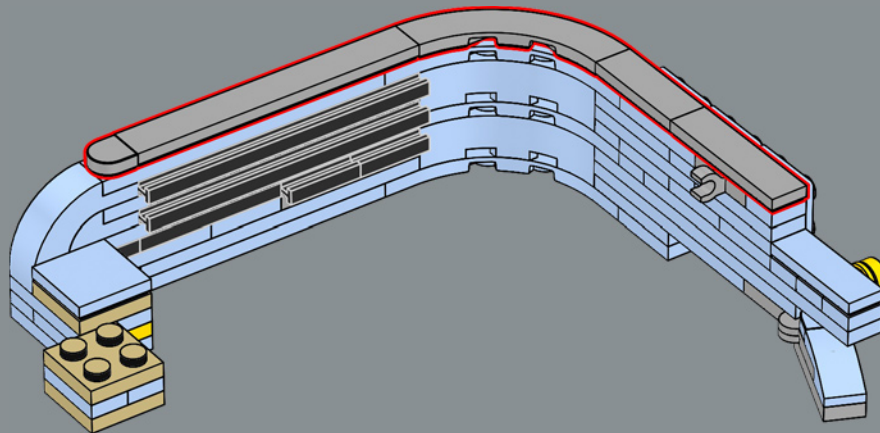

133

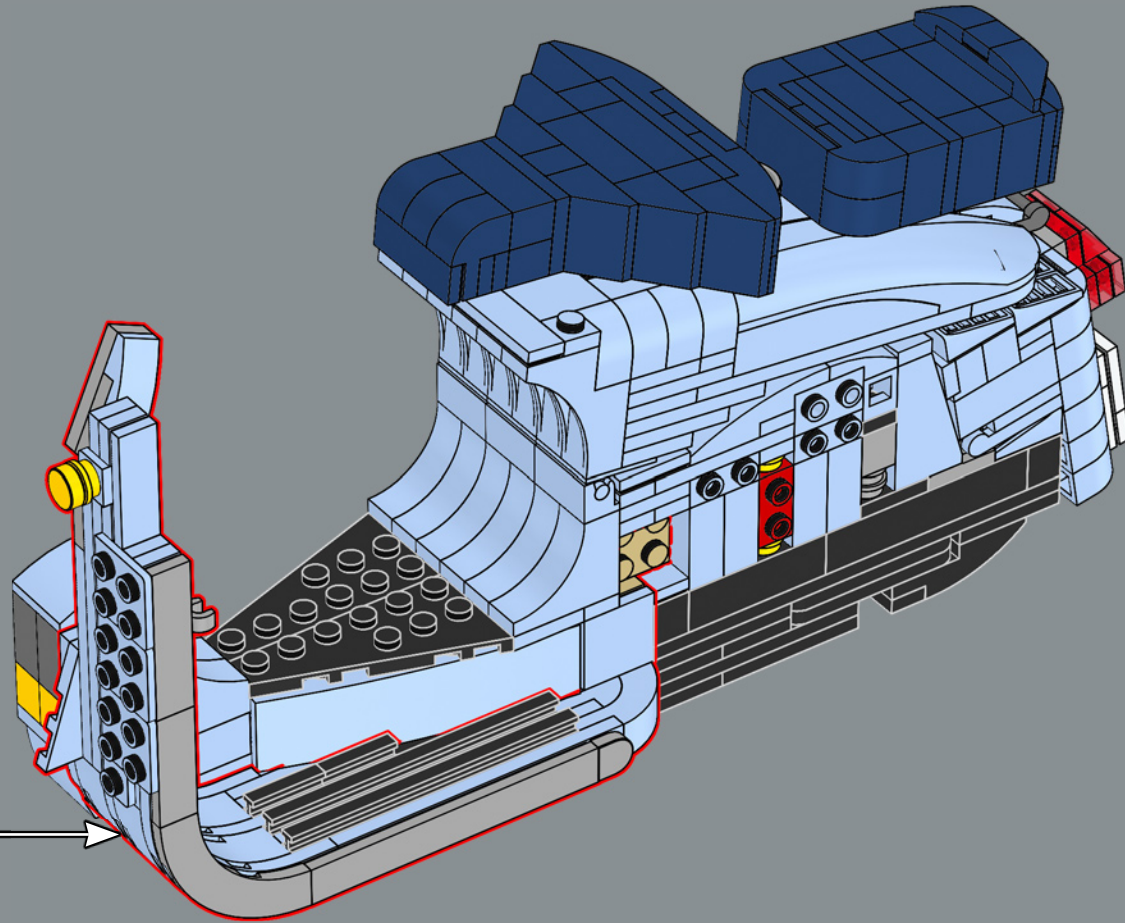

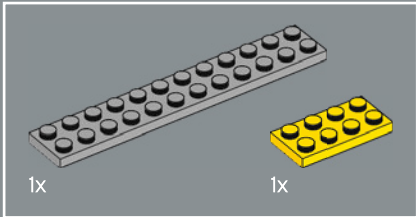
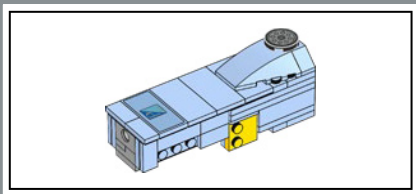

134

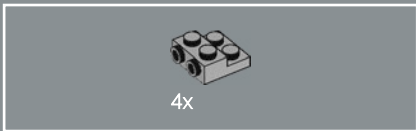
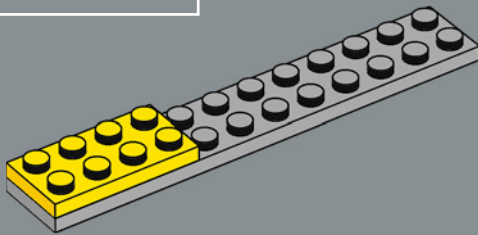

135

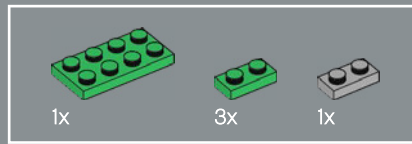
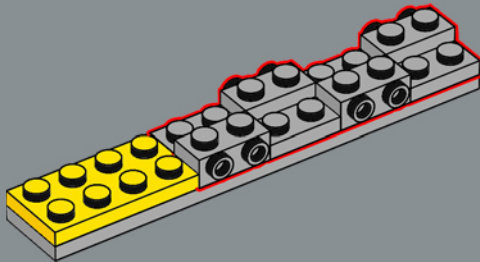

136

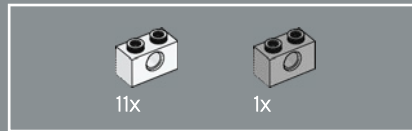
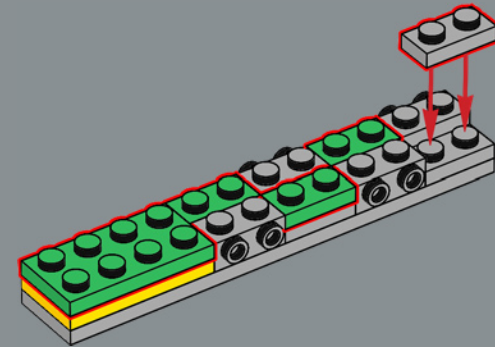

137

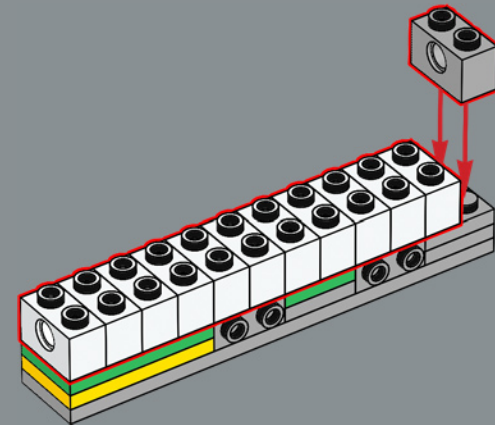

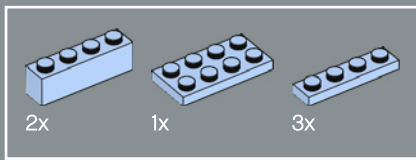

138

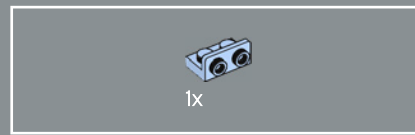
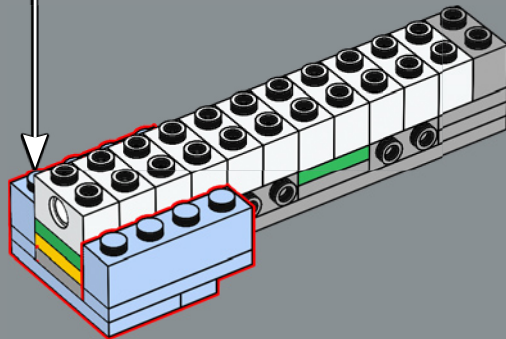
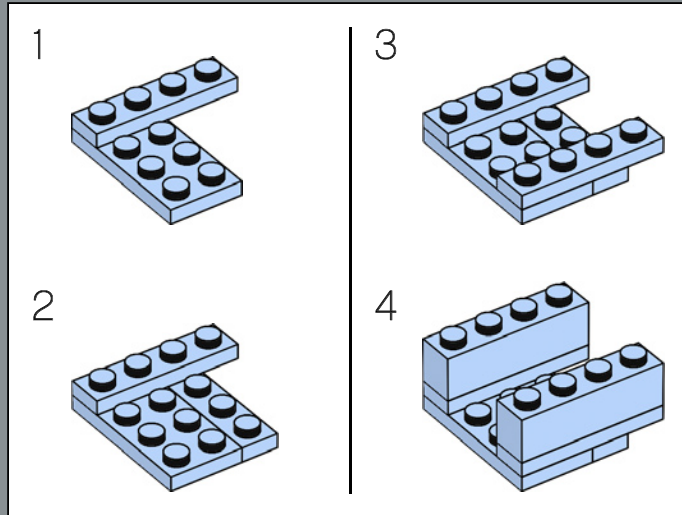

139

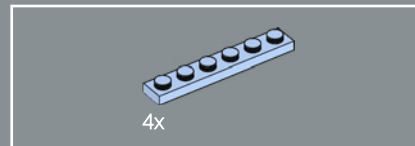
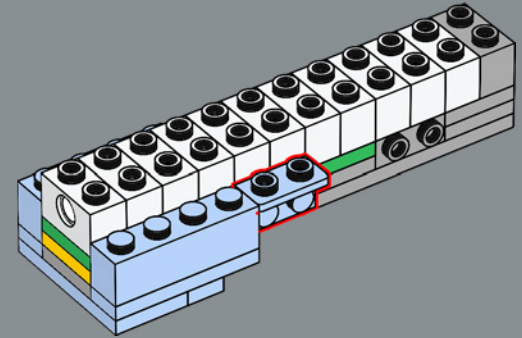

140

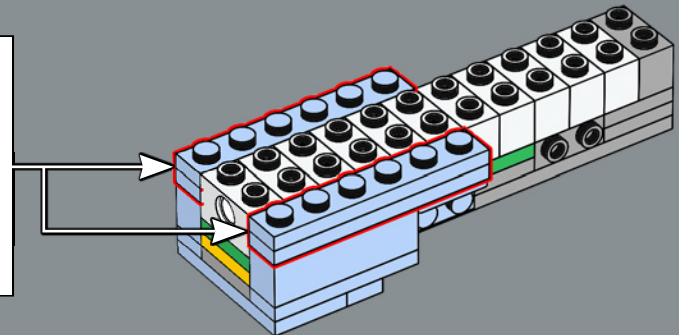
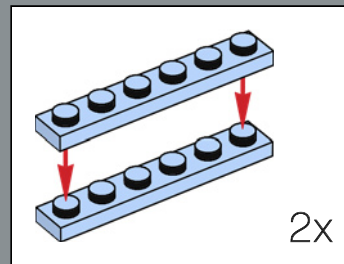

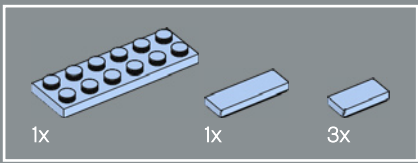

141

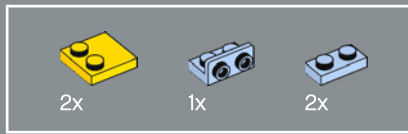
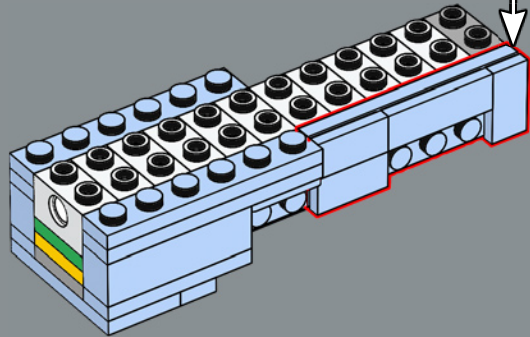
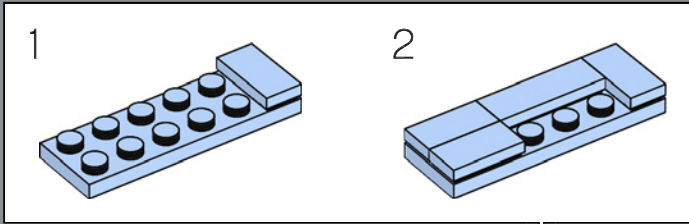

142

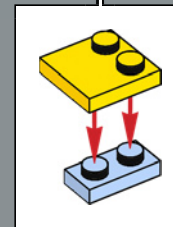
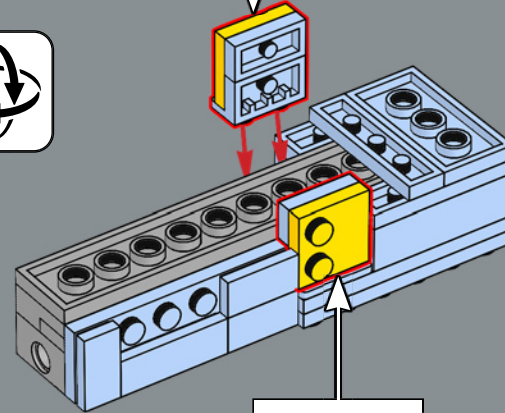
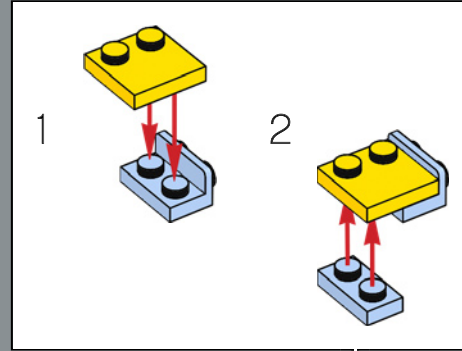

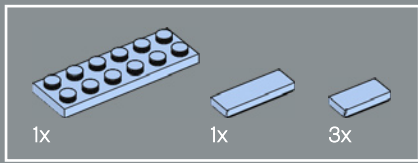

143

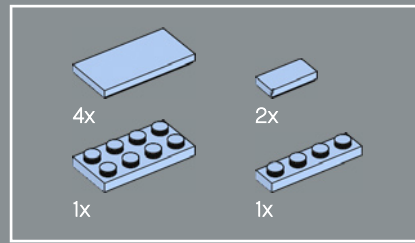
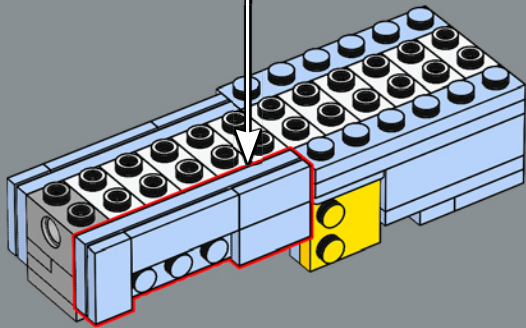
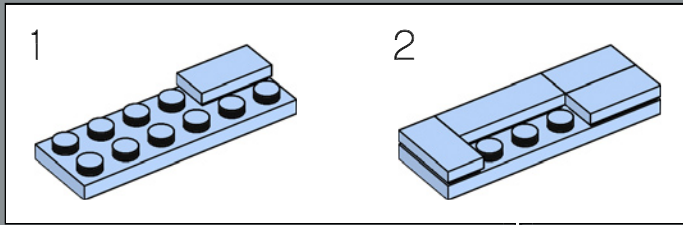

144

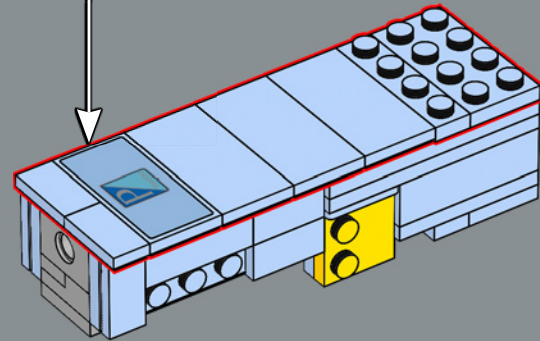
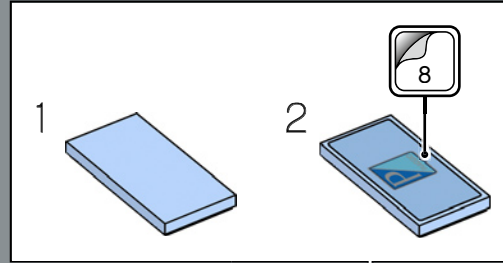

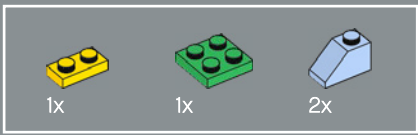

145

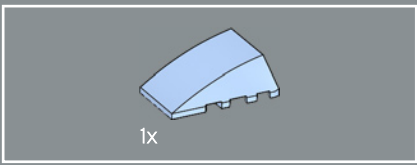
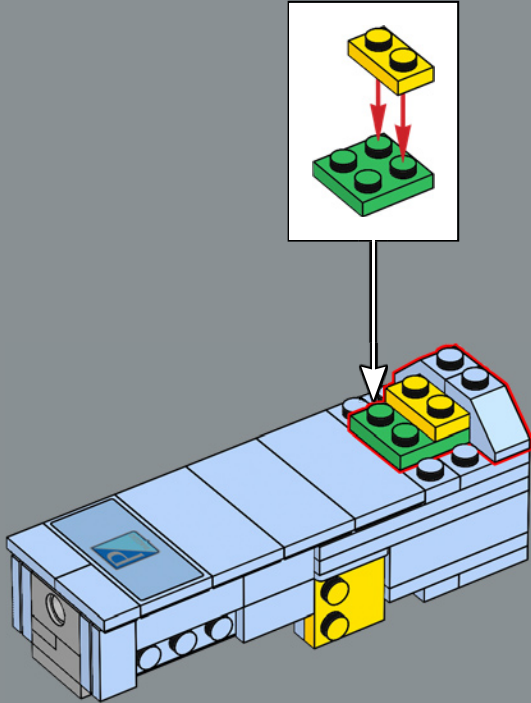

146

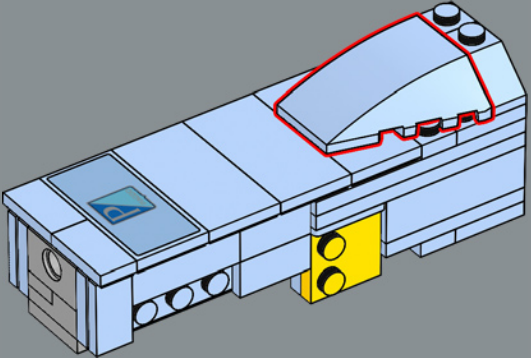



147

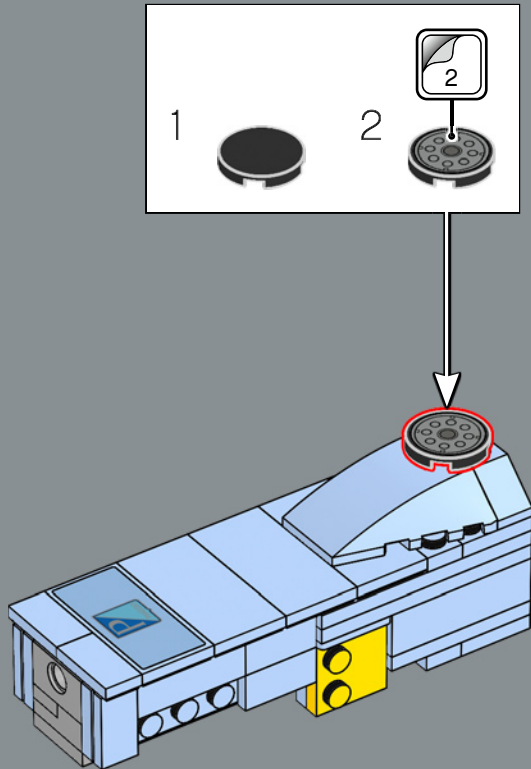

148

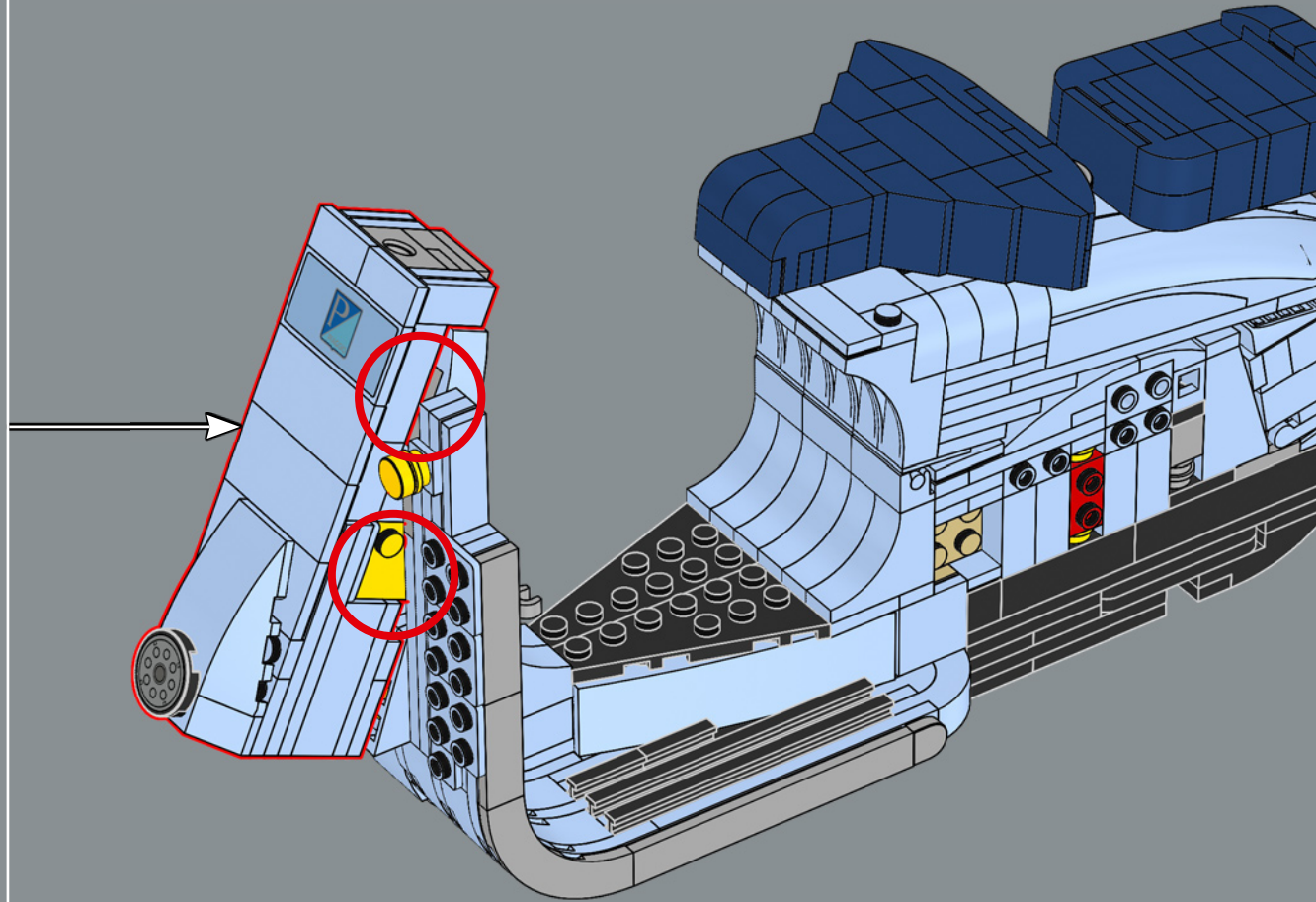

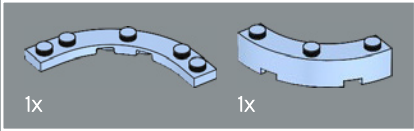
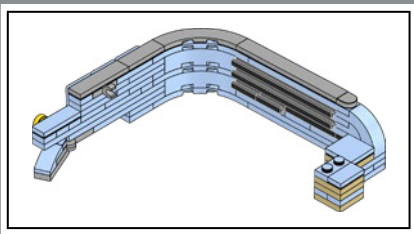

149

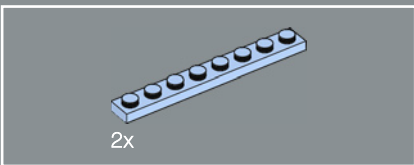
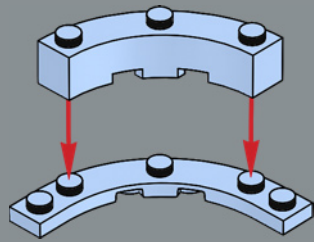

150

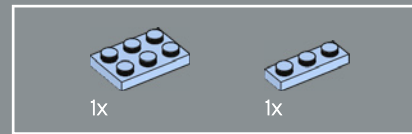
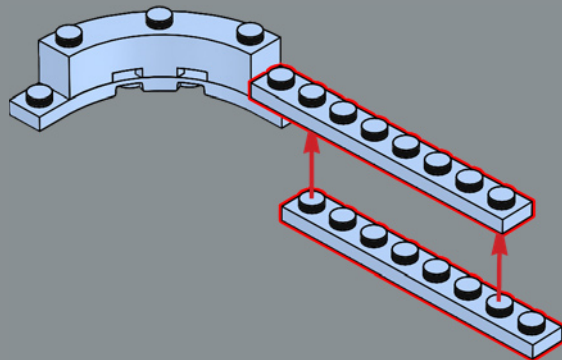

151

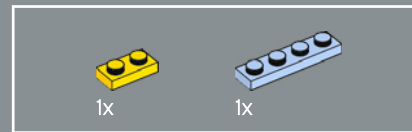
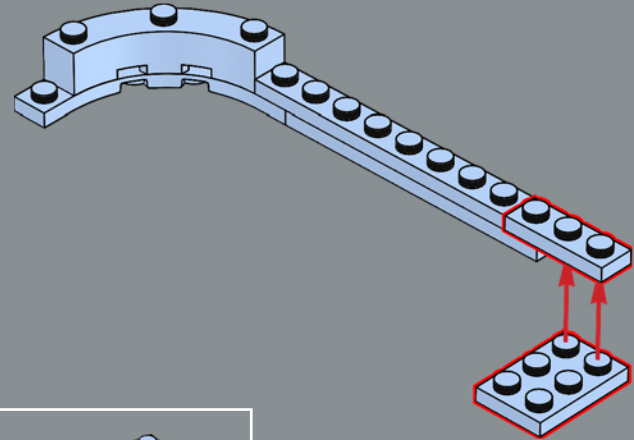

152

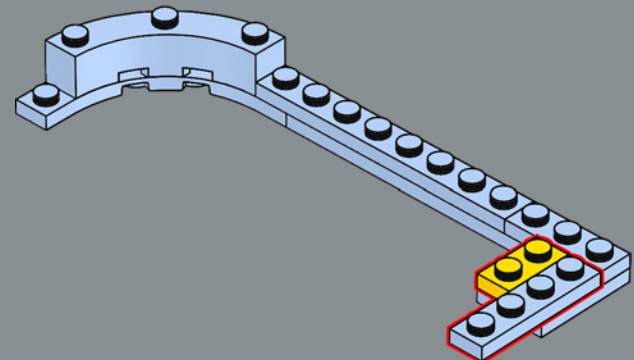

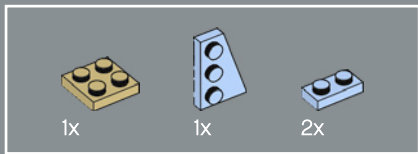

153

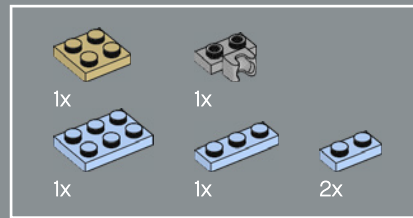
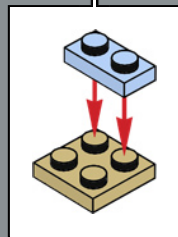
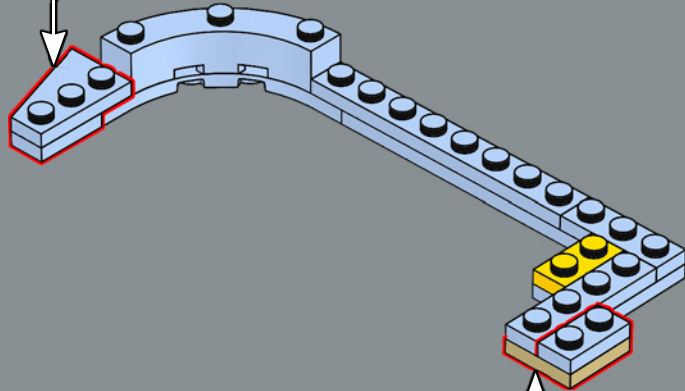
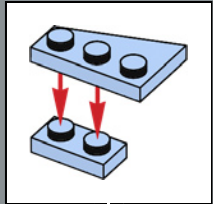

154

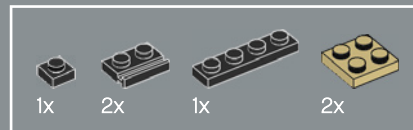
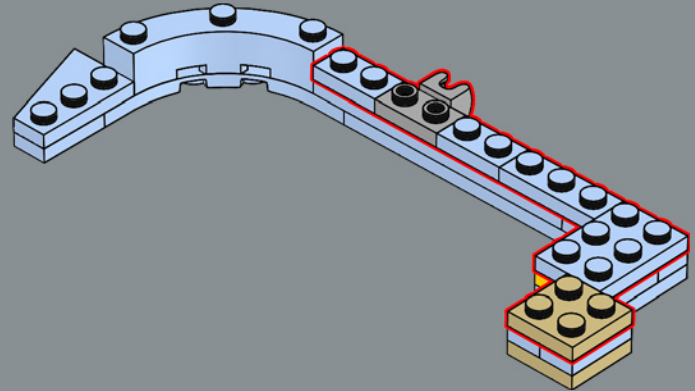

155

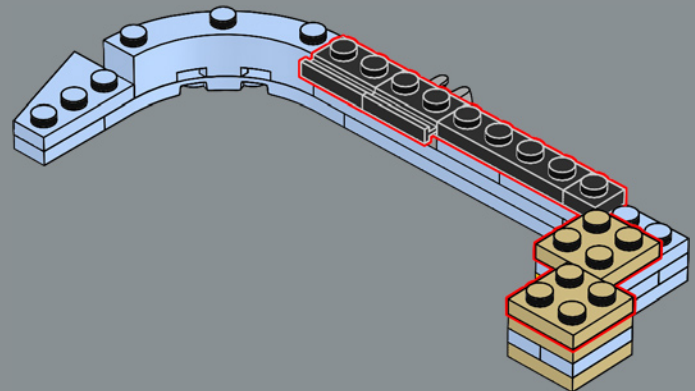

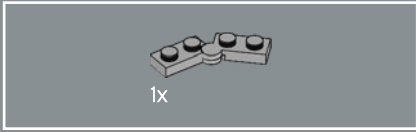
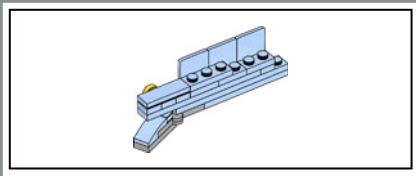

156

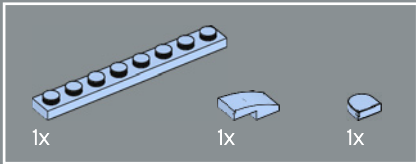
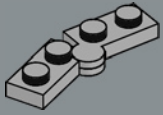

157

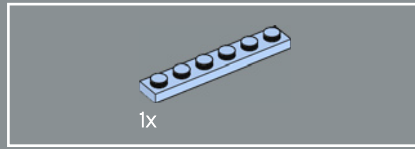
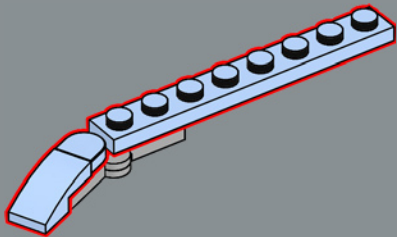

158

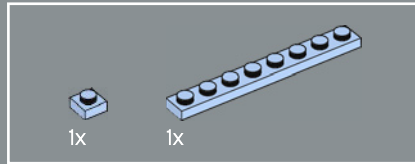
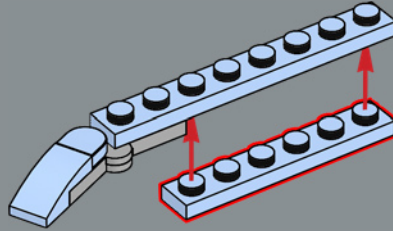

159

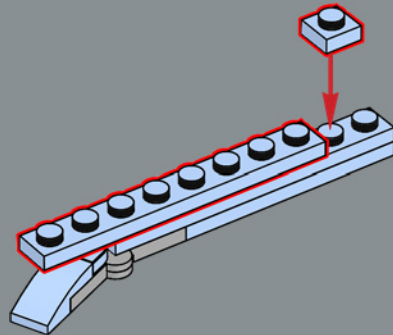

160

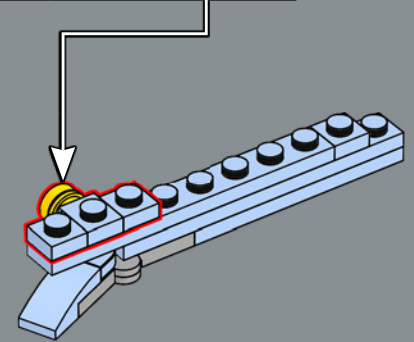
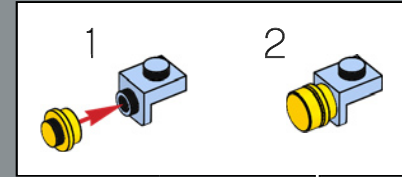

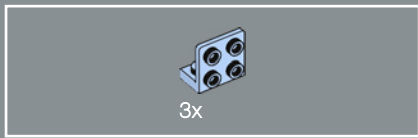

161

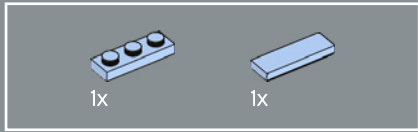
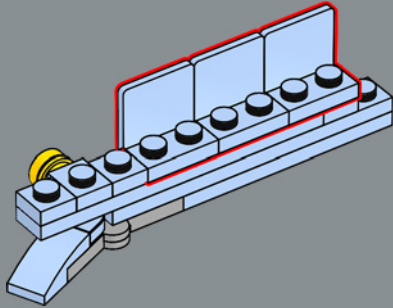

162

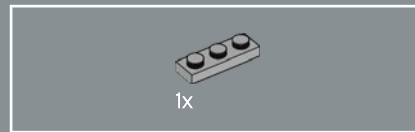
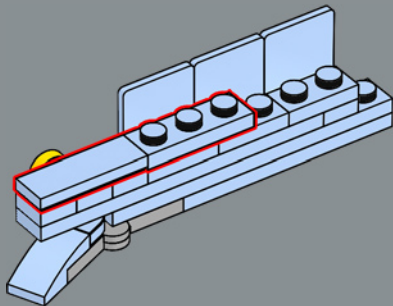

163

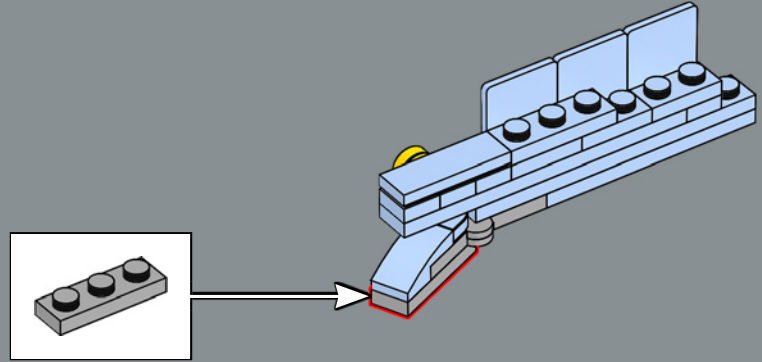

164

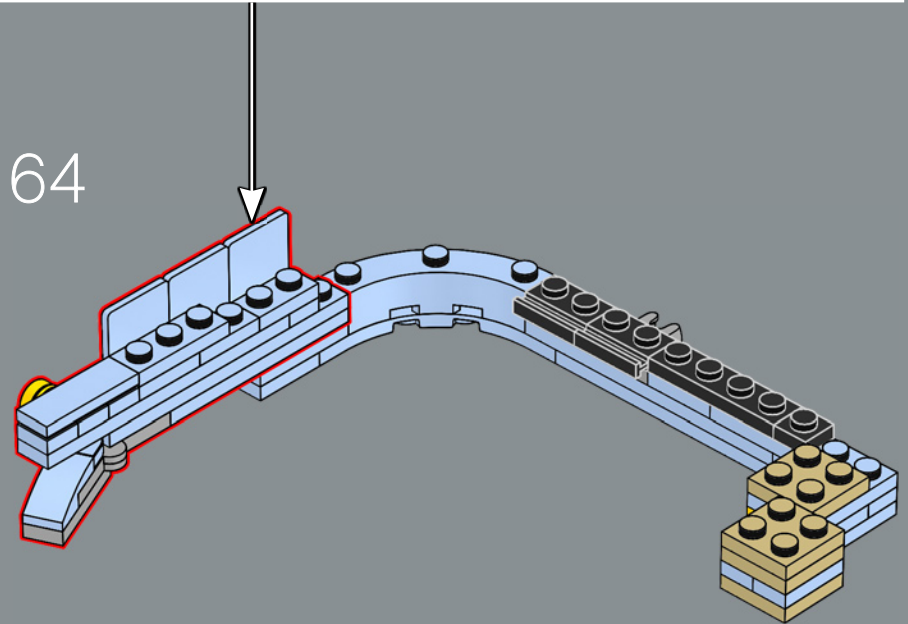

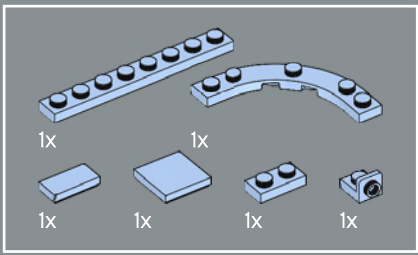

165

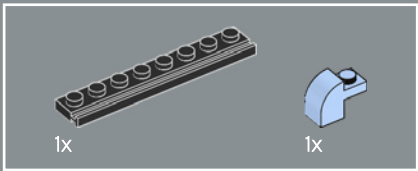
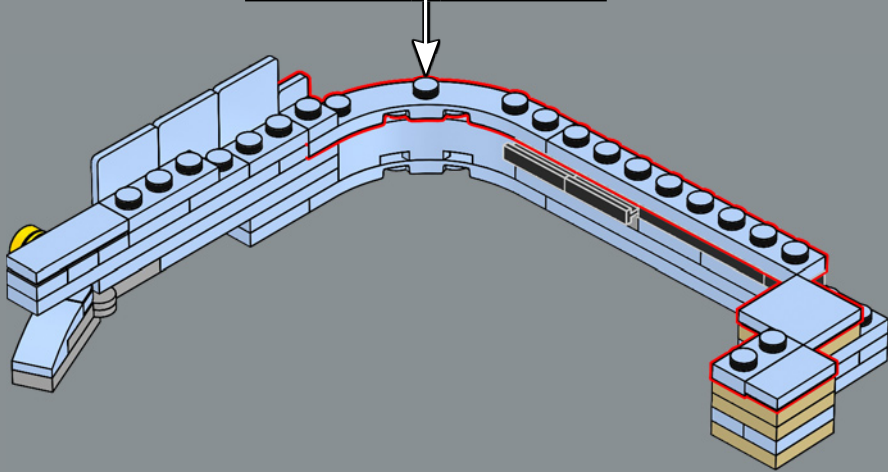
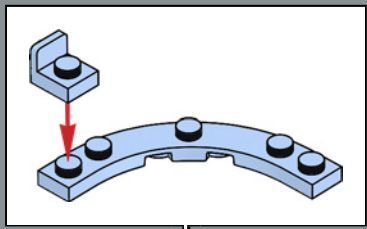

166

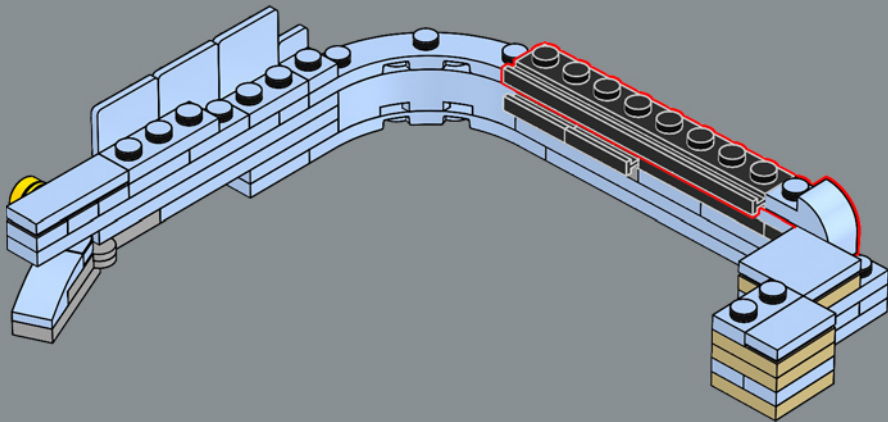

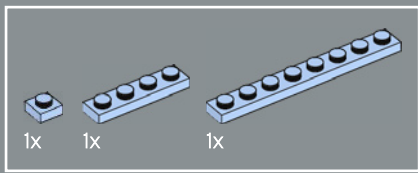

167

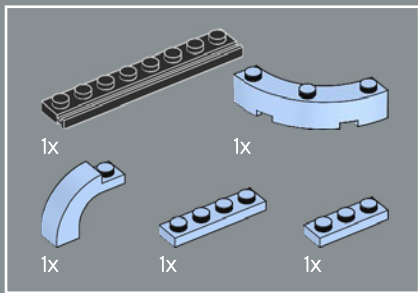
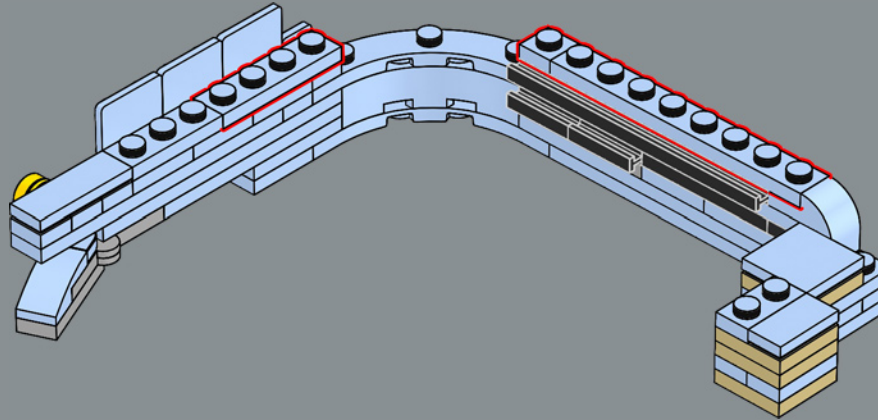

168

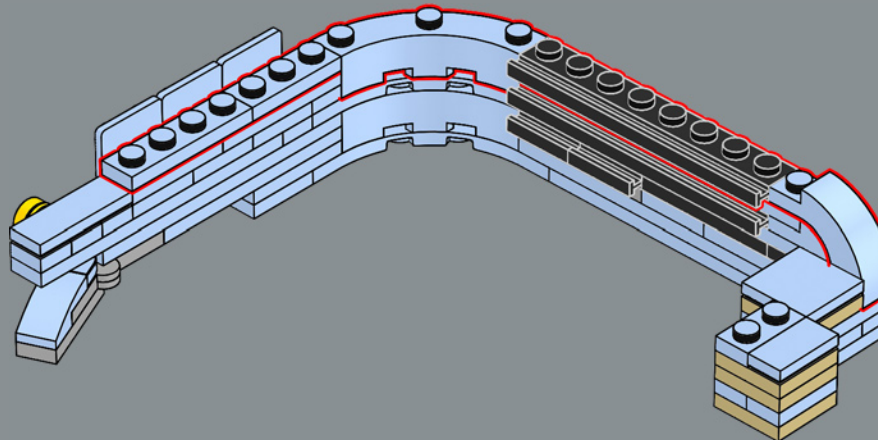

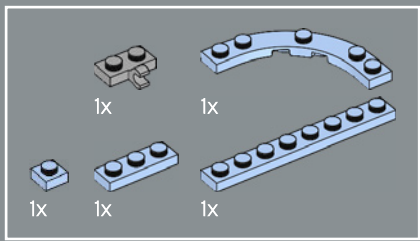

169

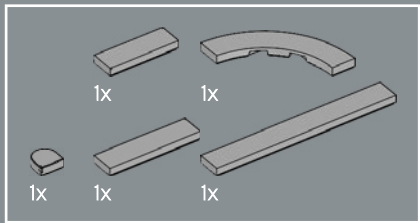
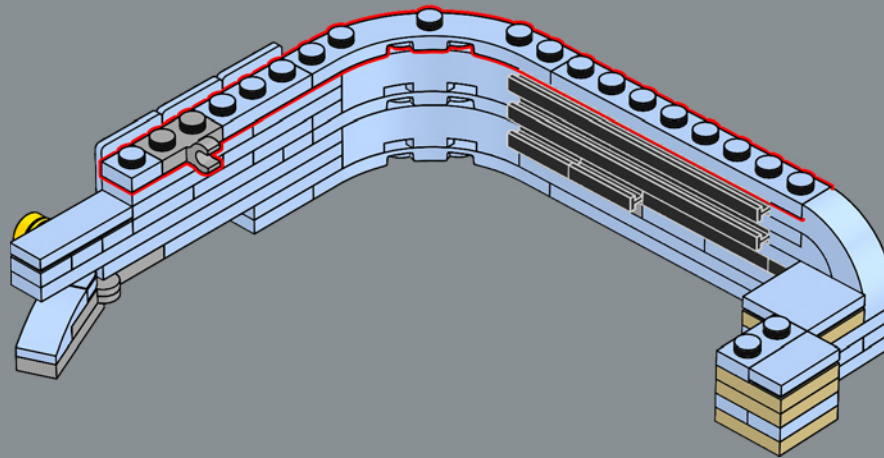

170

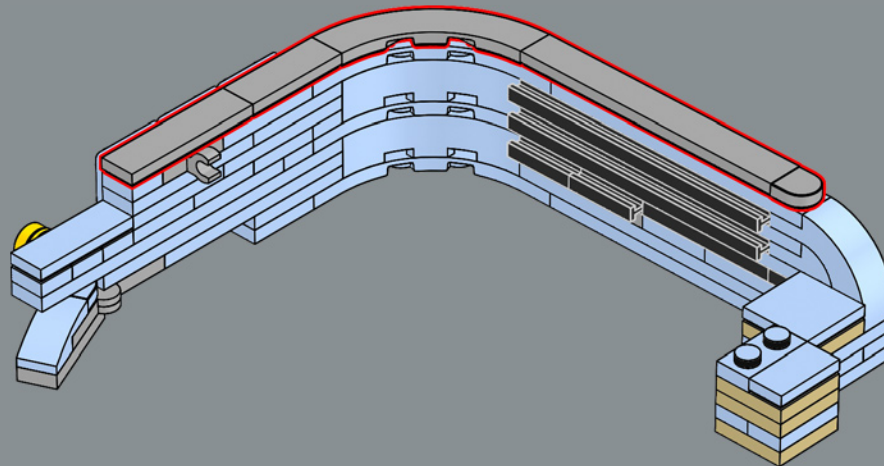

171

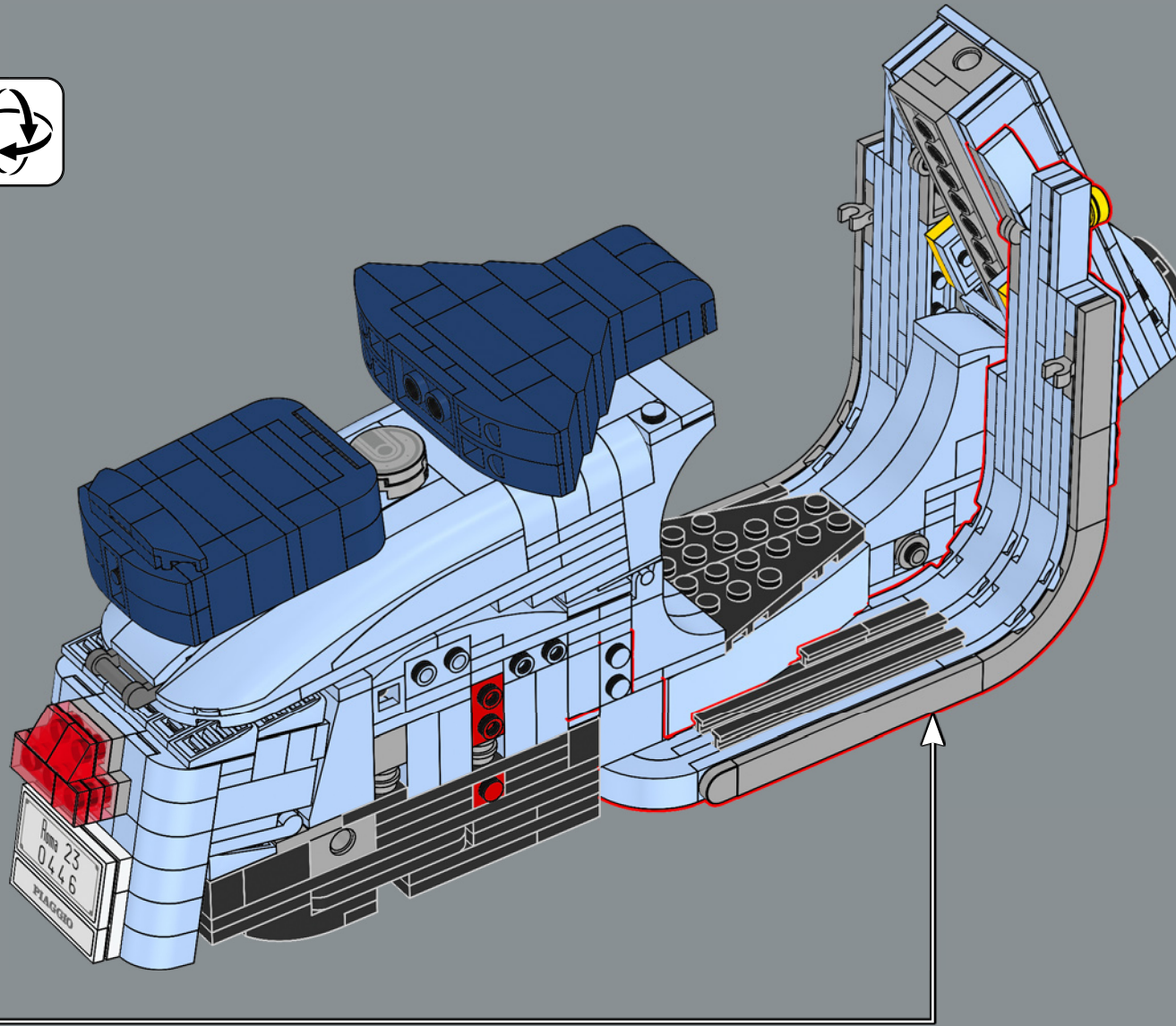

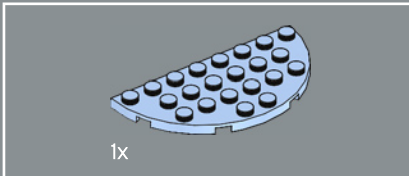
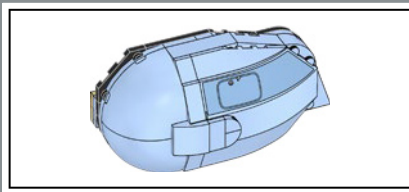
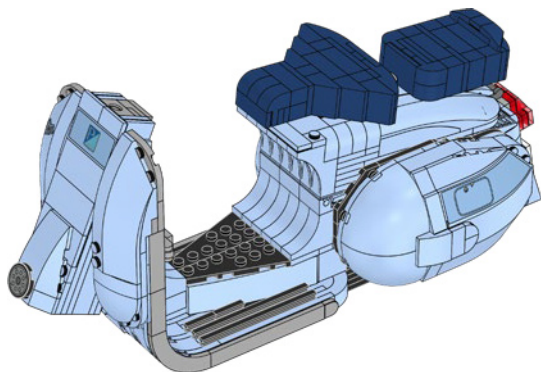
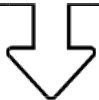

173

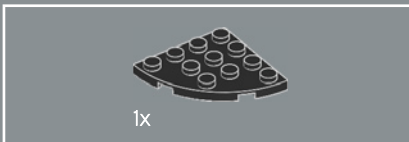
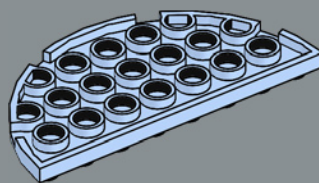

174

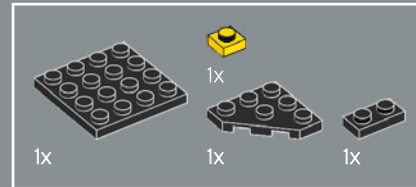
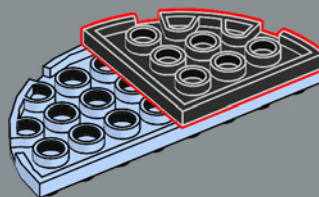

175

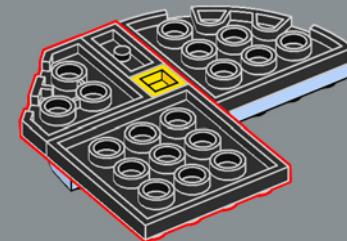

176

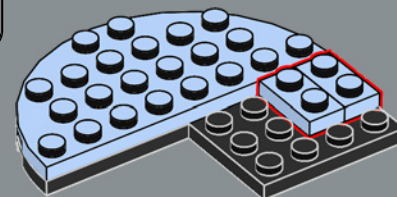

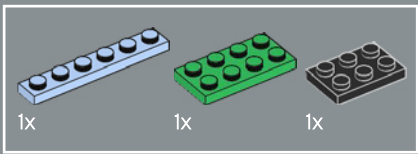

177

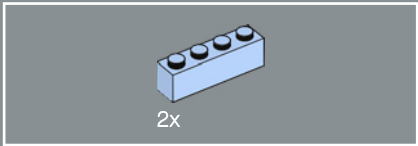
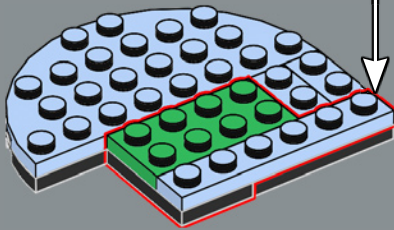
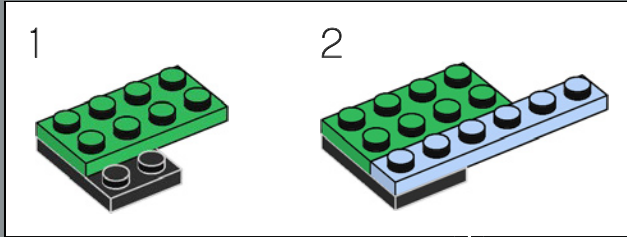

178

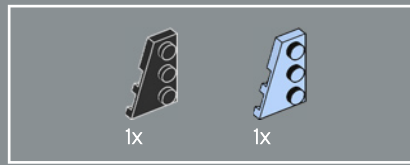
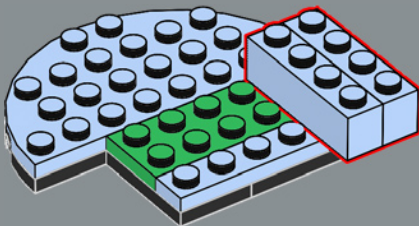

179

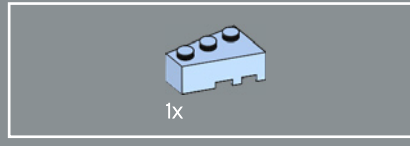
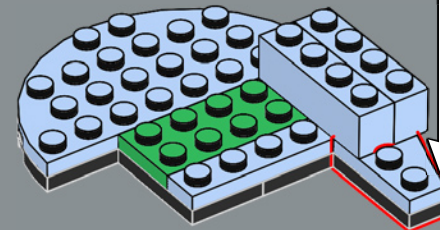
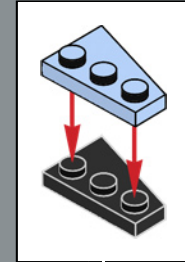

180

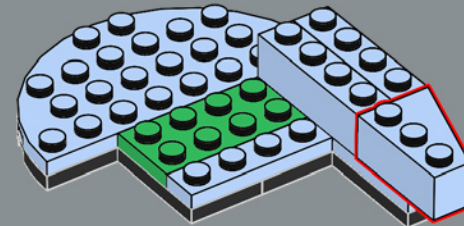

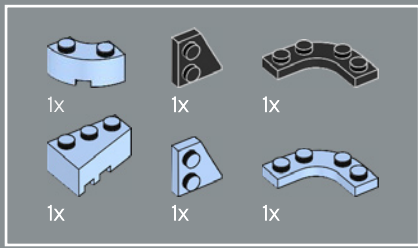

181

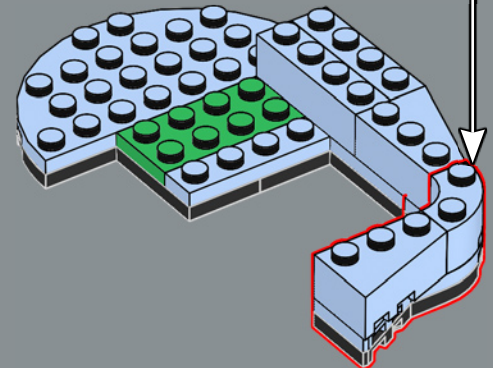
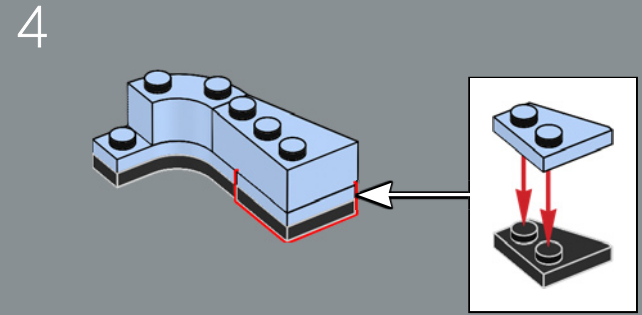
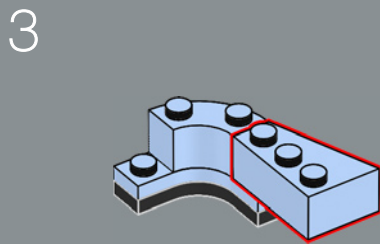
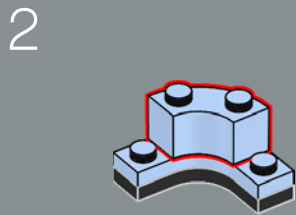
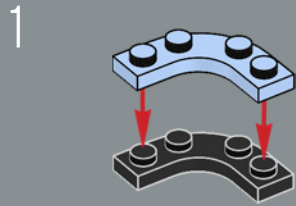

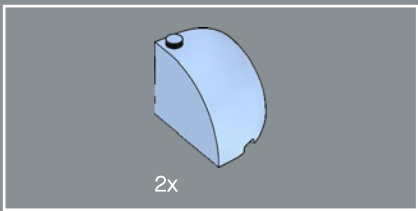

182

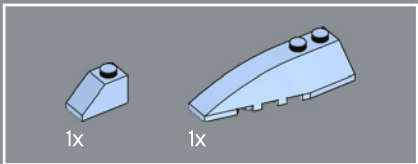
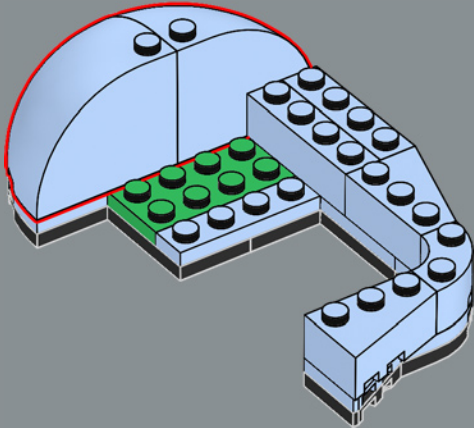

183

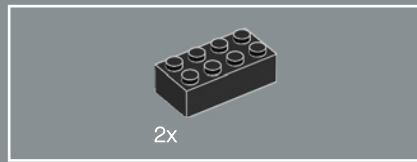
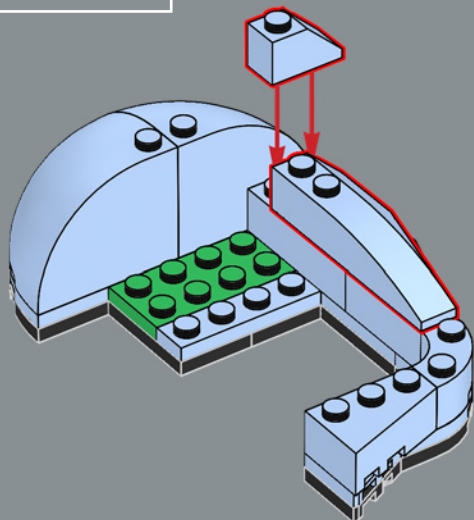

184

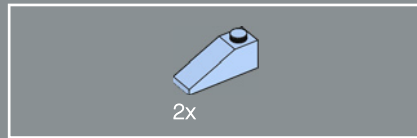
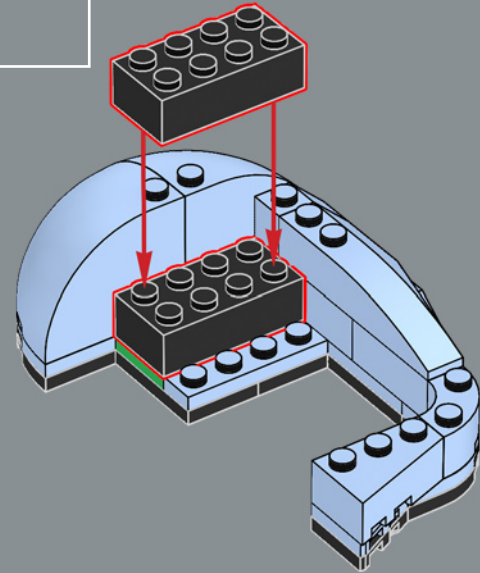

185

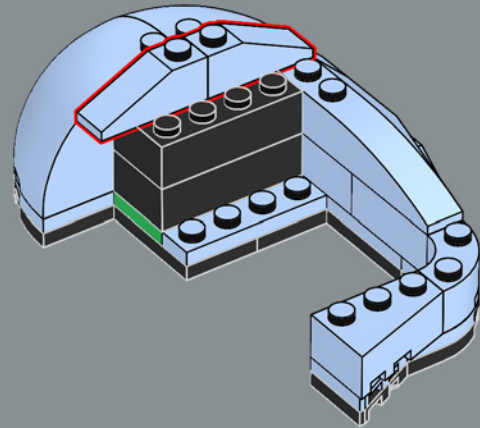

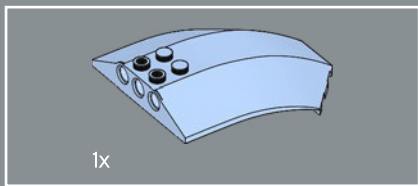

186

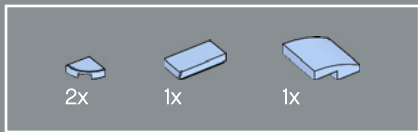
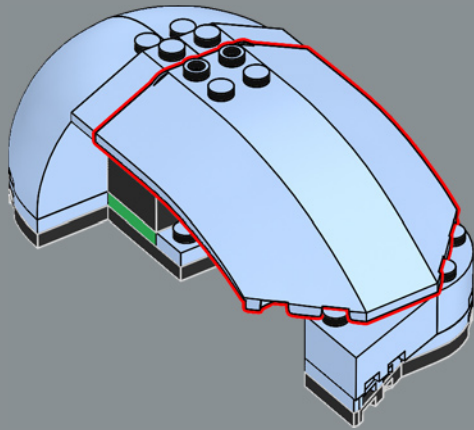

187

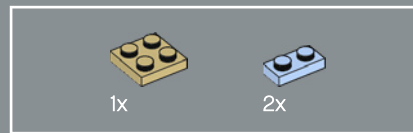
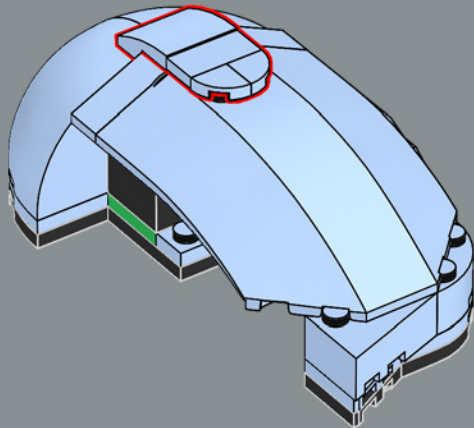

188

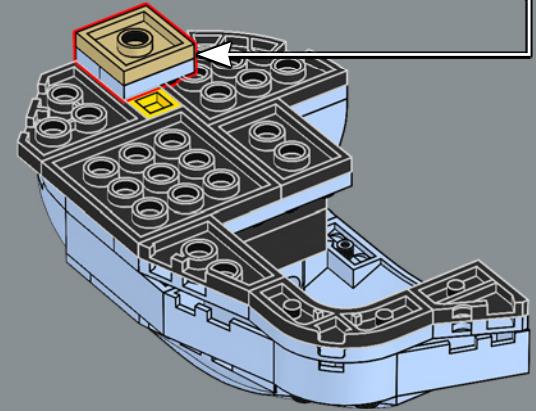
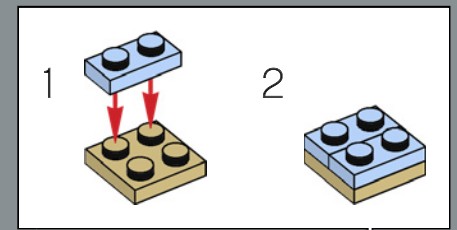

189

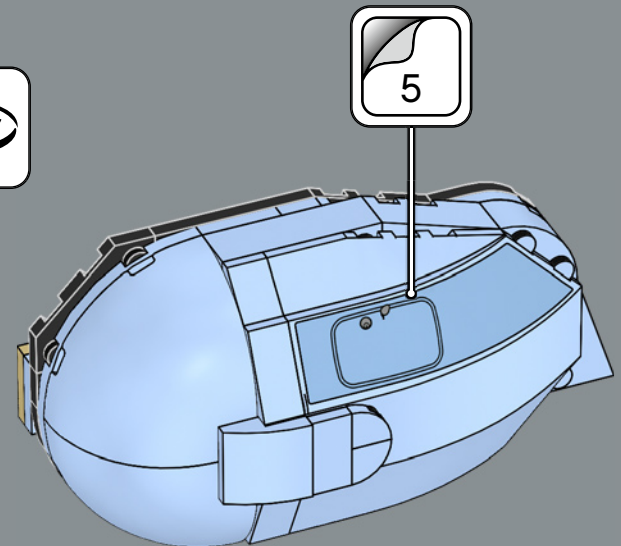



190

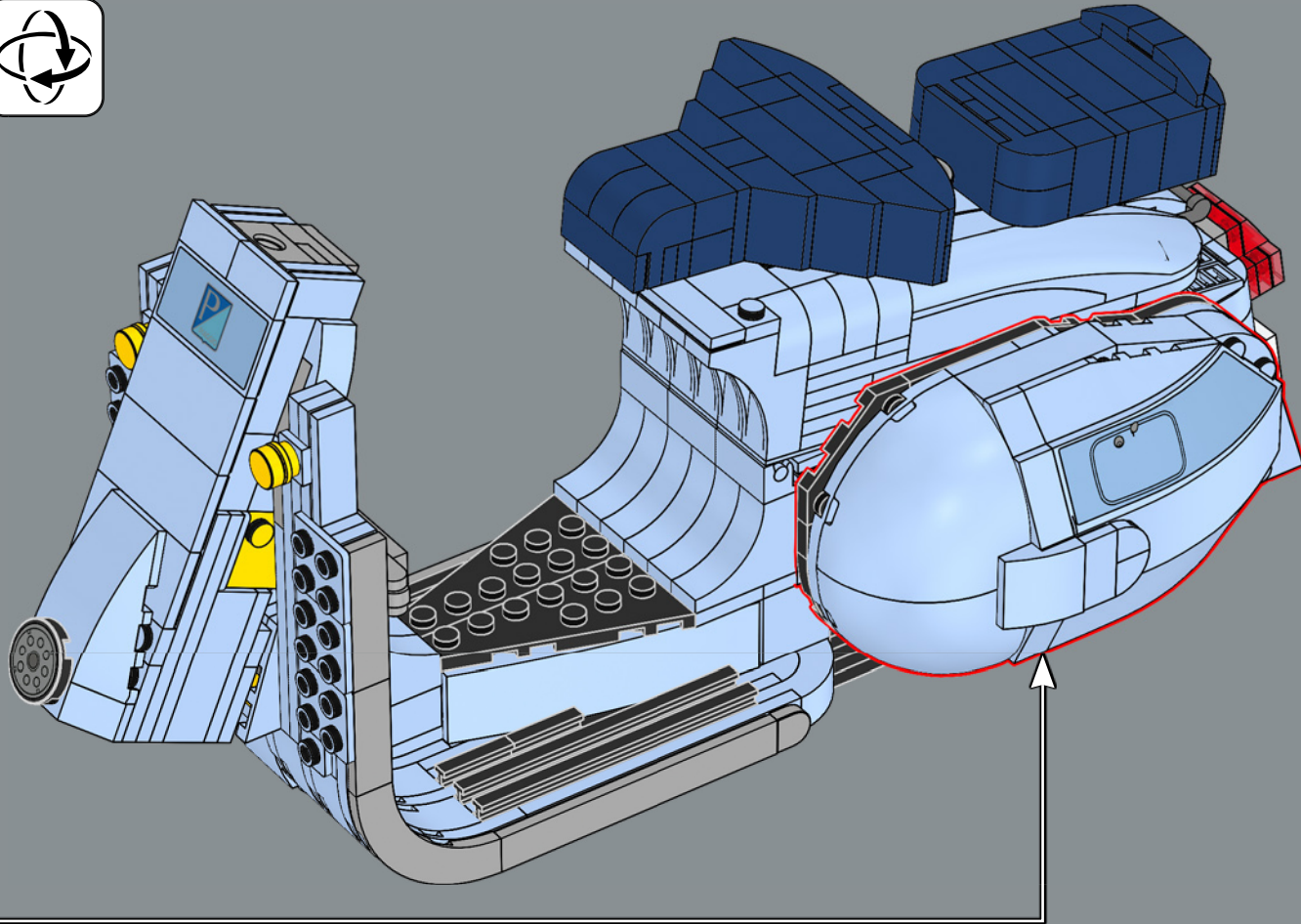

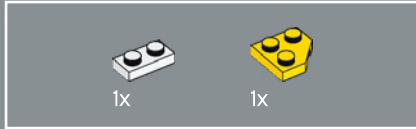
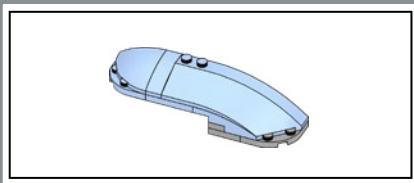

191

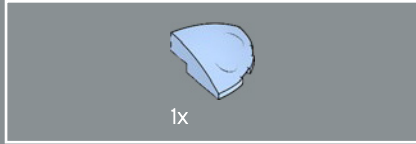

192

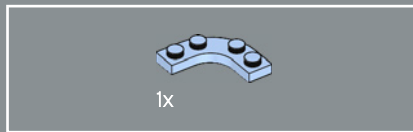

193

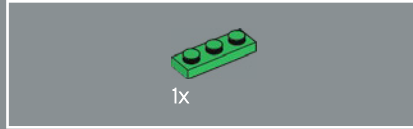
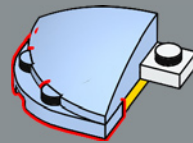

194

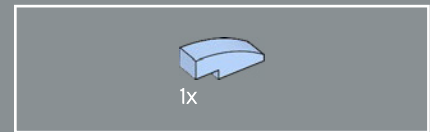
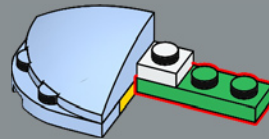

195

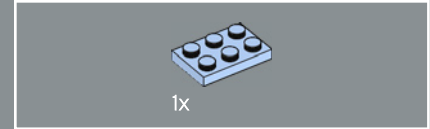
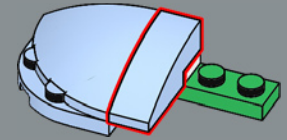

196

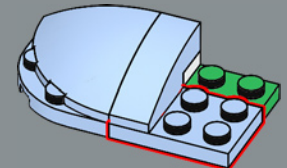

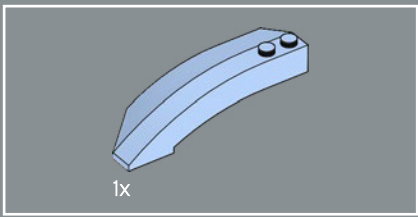

197

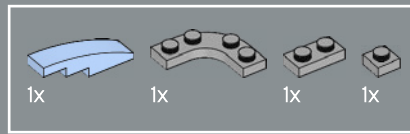
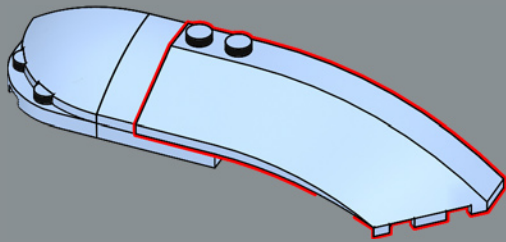

198

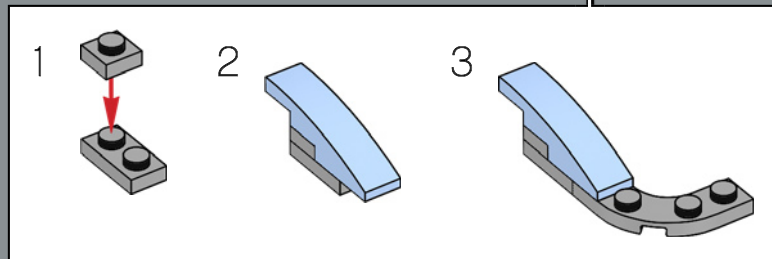
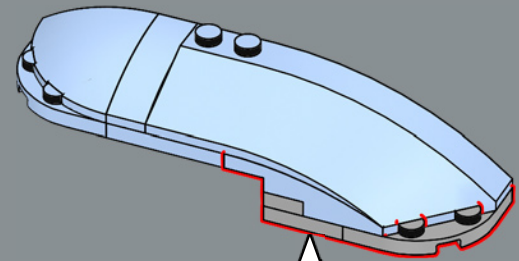

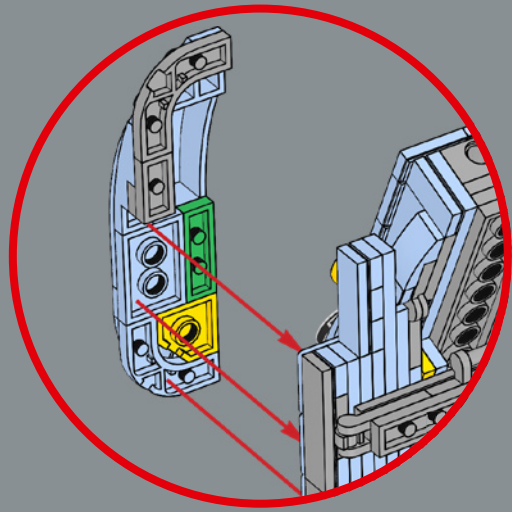

199

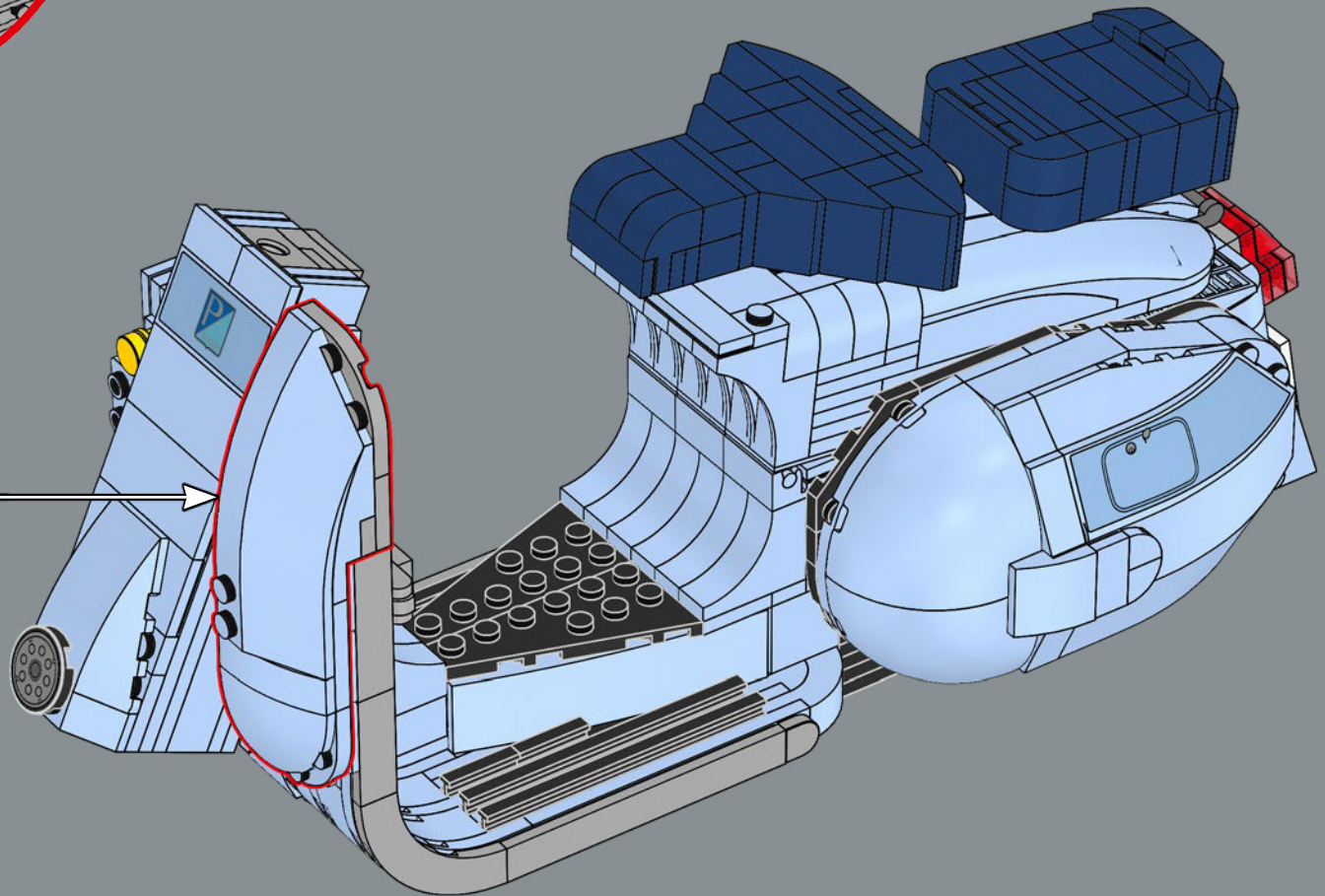

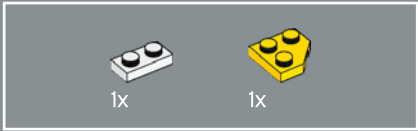
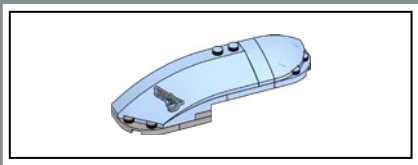

200

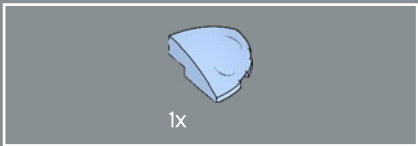

201

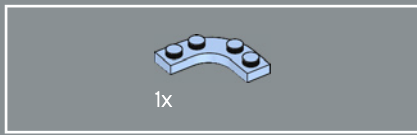

202

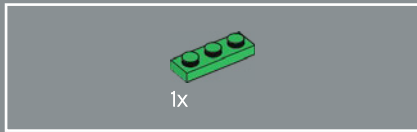

203

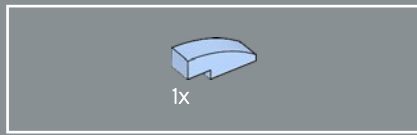
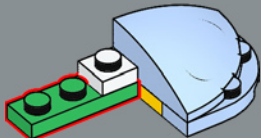

204

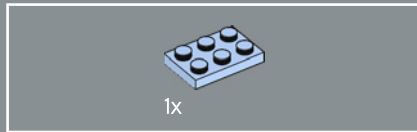
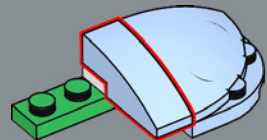

205

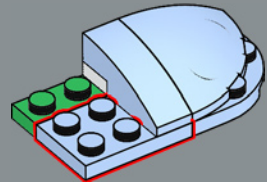

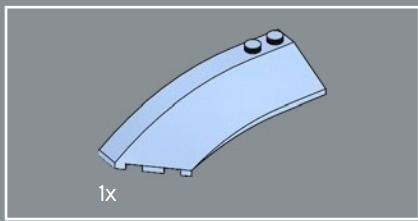

206

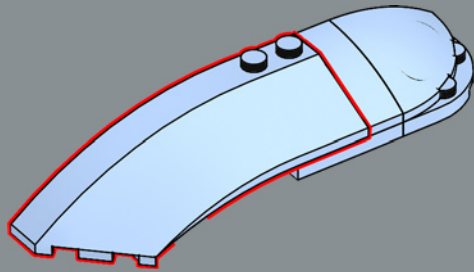

207

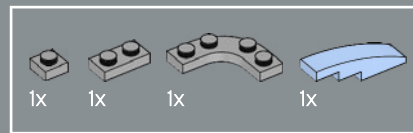
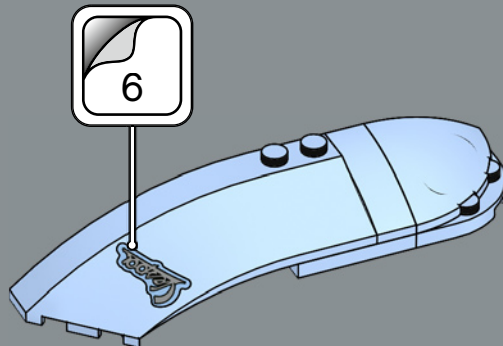

208

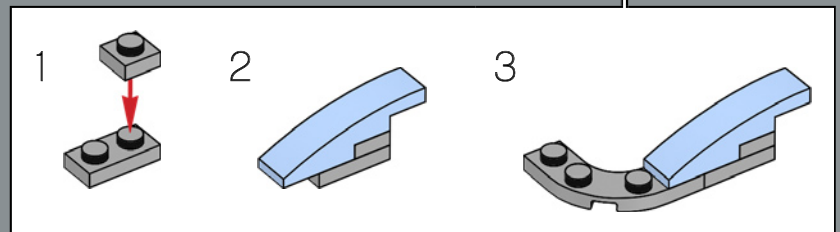
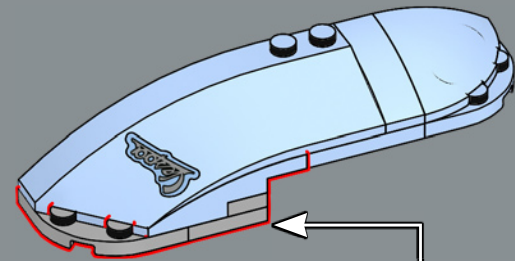

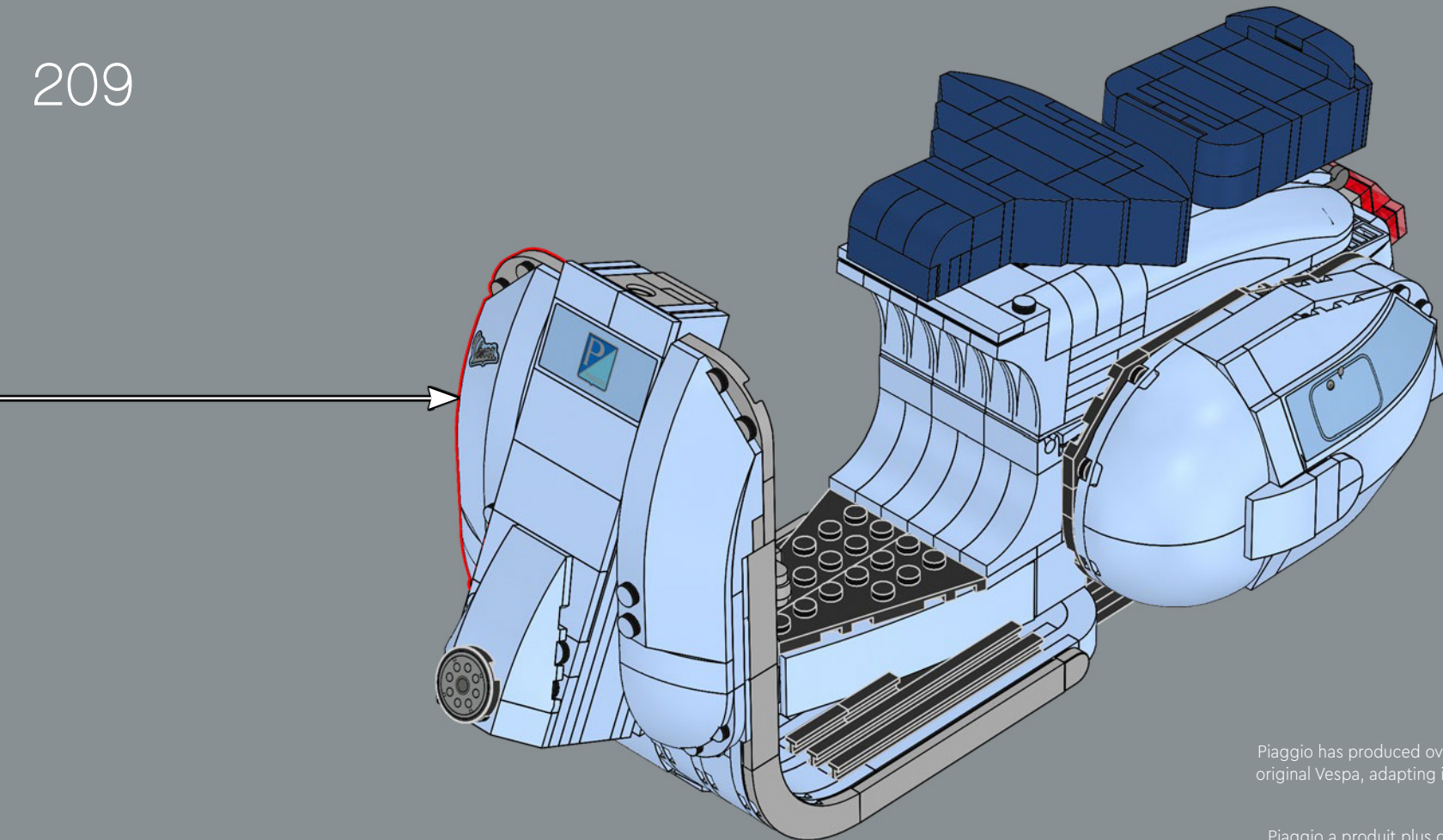

Piaggio has produced over 150 models of the original Vespa, adapting it to changing needs and fashions.

Piaggio a produit plus de 150 modèles de la Vespa originale, l'adaptant aux besoins et aux modes en constante évolution.

Piaggio ha producido más de 150 modelos a partir de la Vespa original, adaptándola a las cambiantes necesidades y modas.

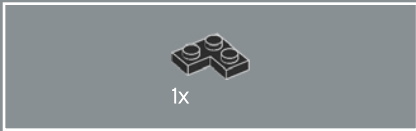
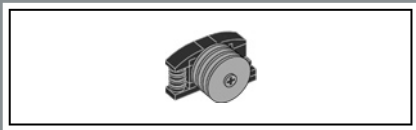

210

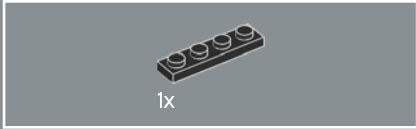

211

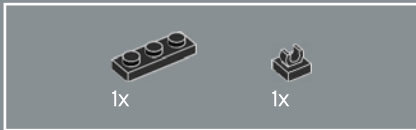
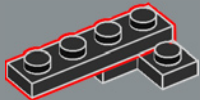

212

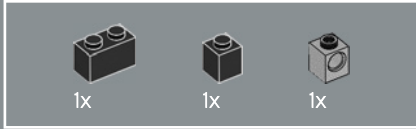
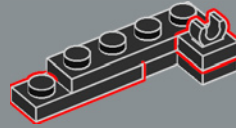

213

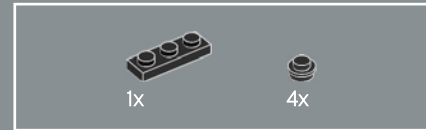
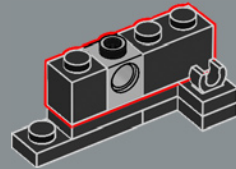

214

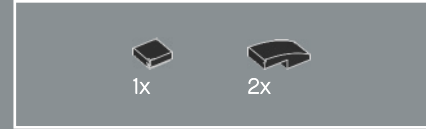
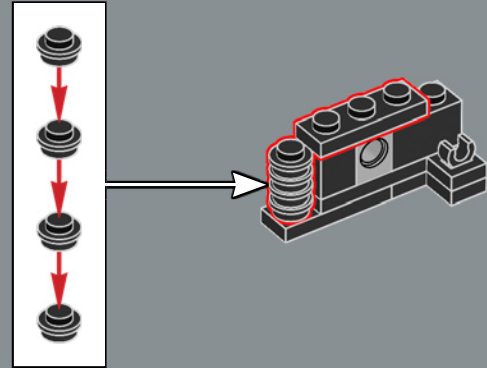

215

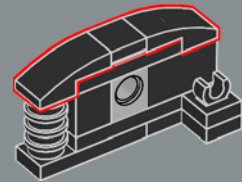

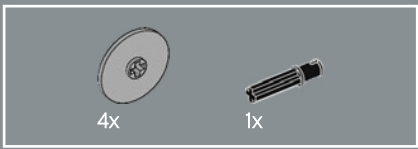

216

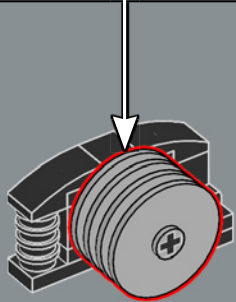
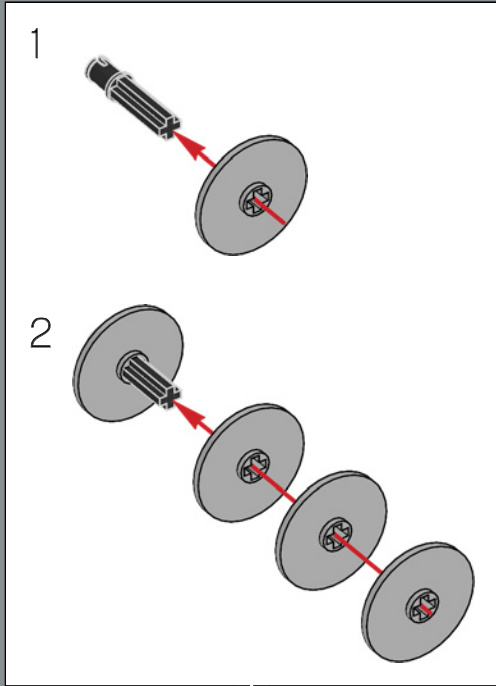

217

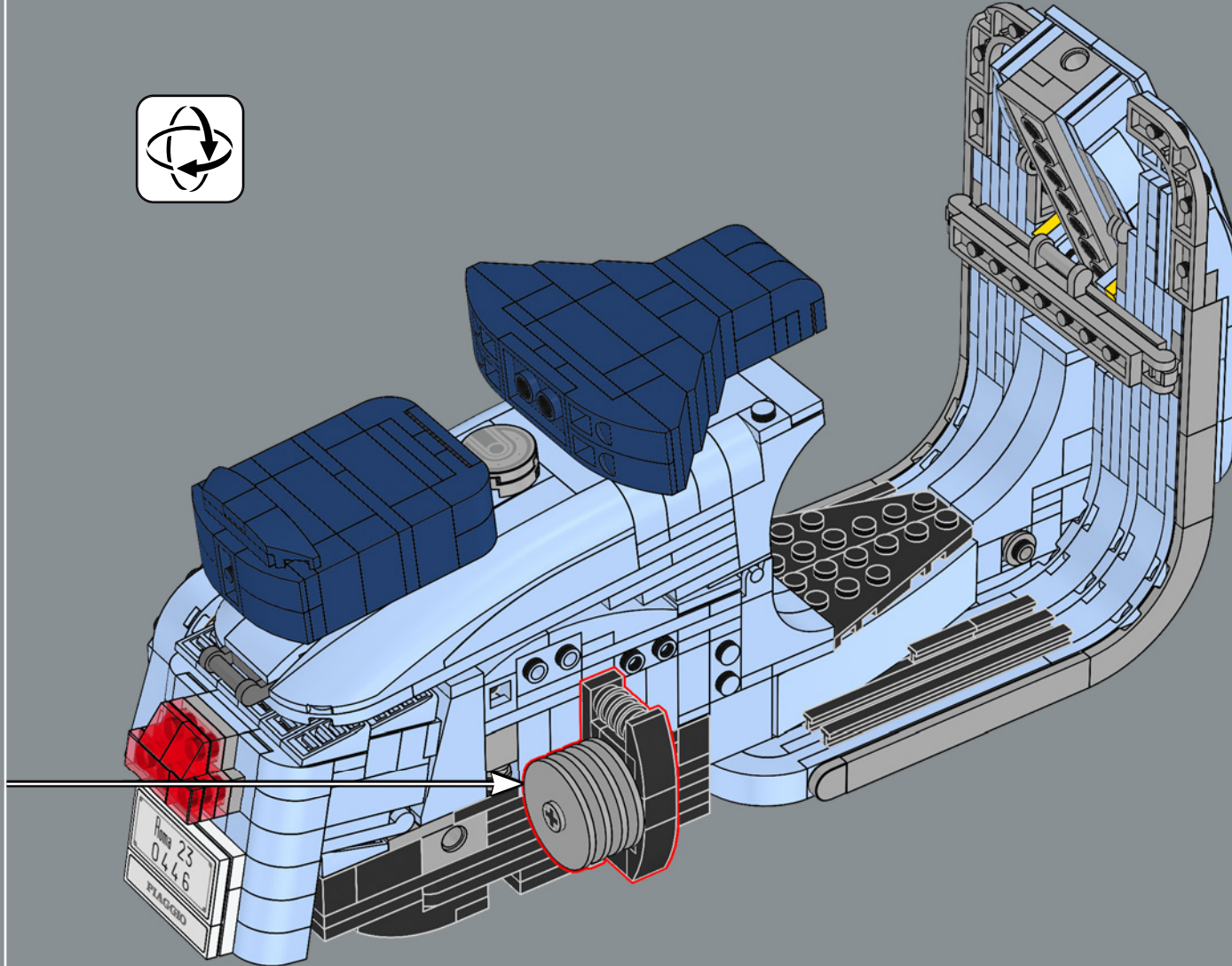

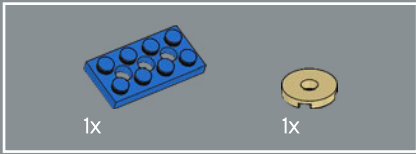
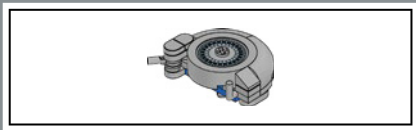

218

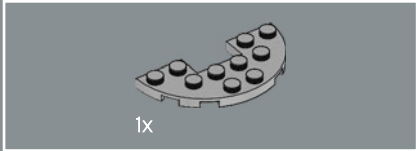
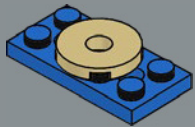

218

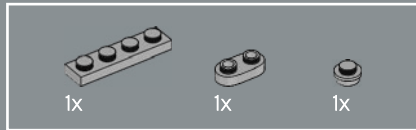
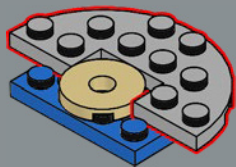

220

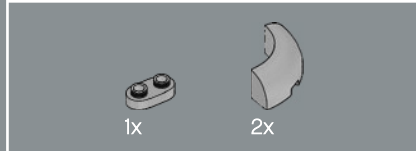
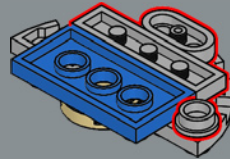

221

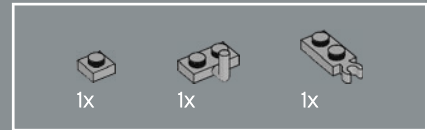
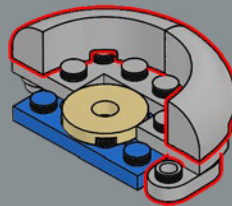

222

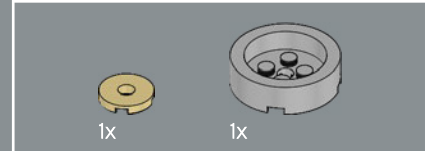
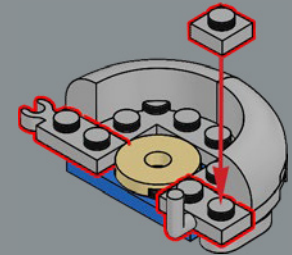

223

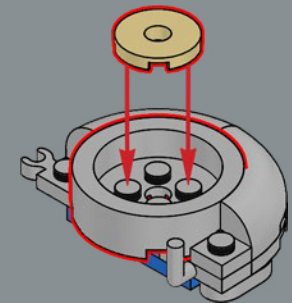

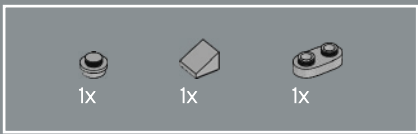

224

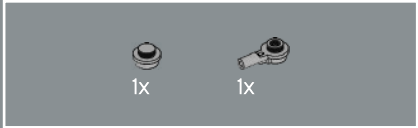
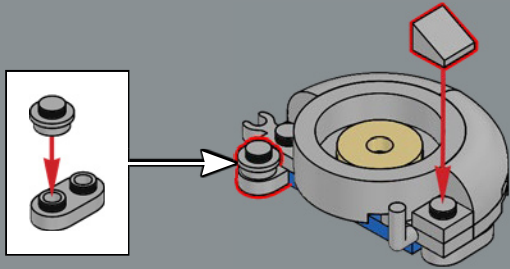

225

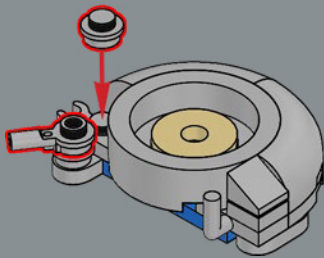

226

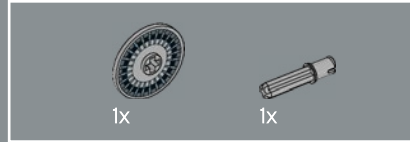
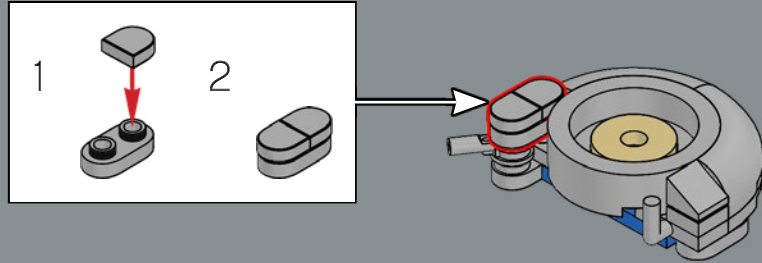

227

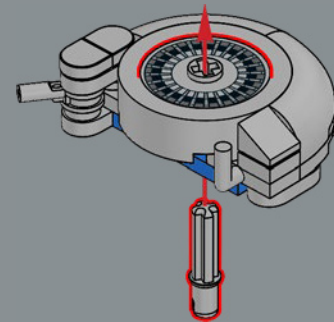

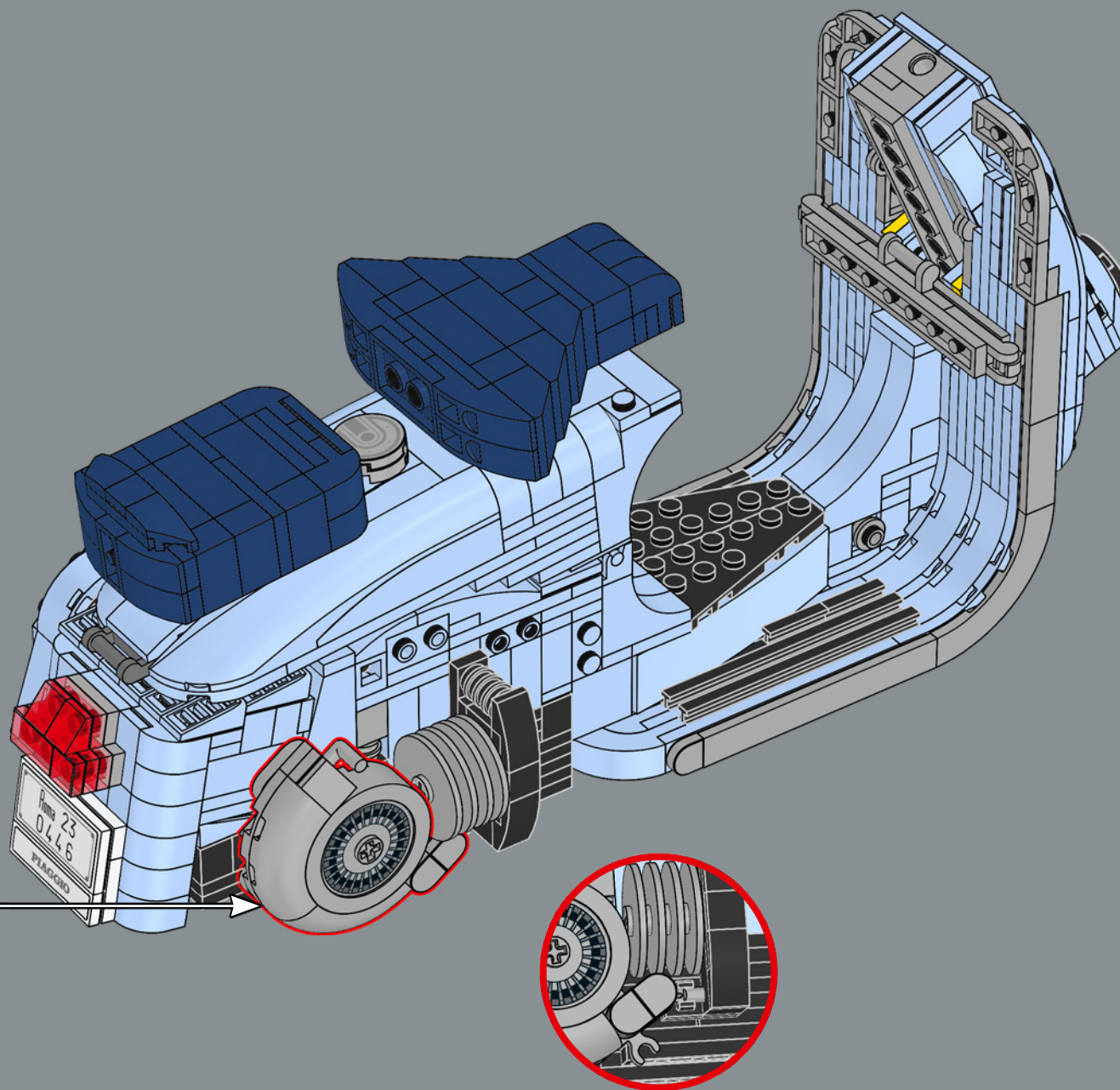

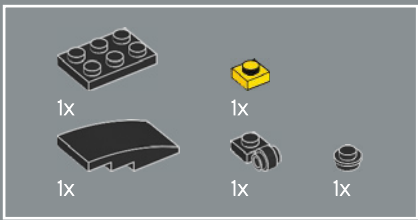

229

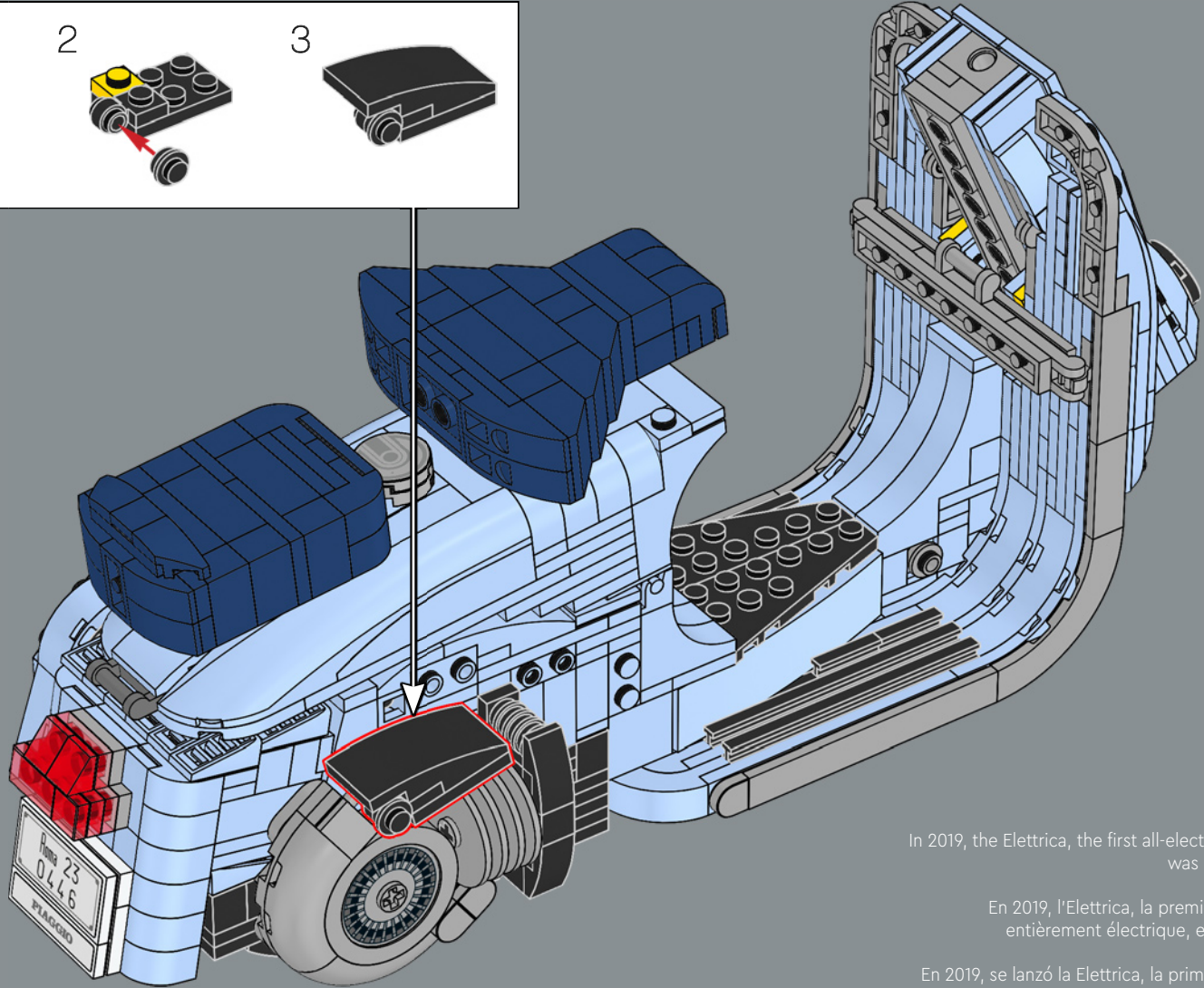
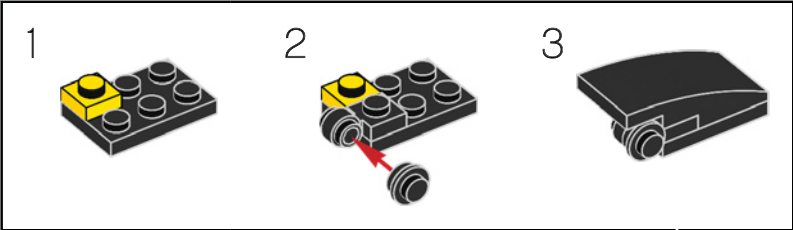

In 2019, the Elettrica, the first all-electric Vespa, was launched.

En 2019, l'Elettrica, la première Vespa entièrement électrique, est lancée.

En 2019, se lanzó la Elettrica, la primera Vespa completamente eléctrica.

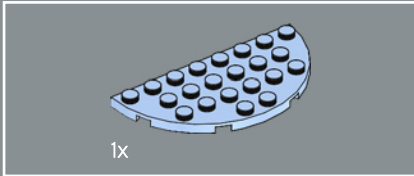
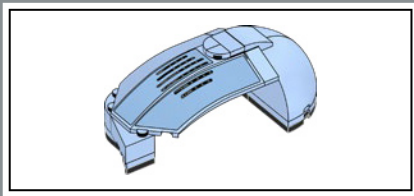

230

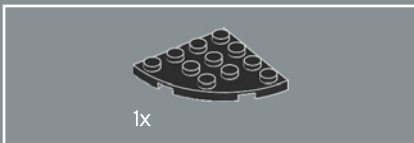
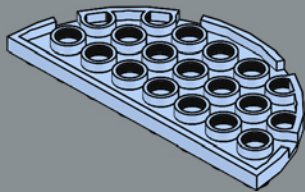

231

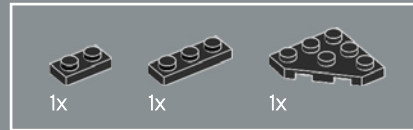
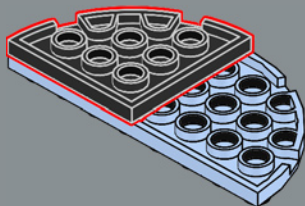

232

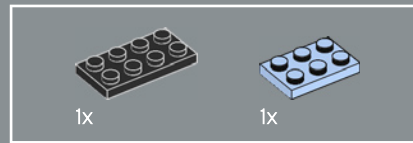
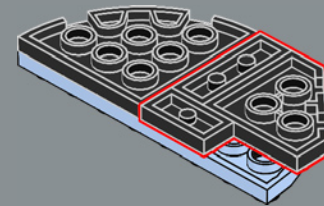

233

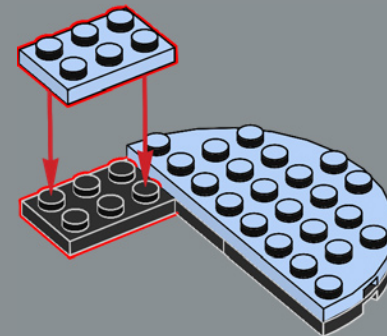

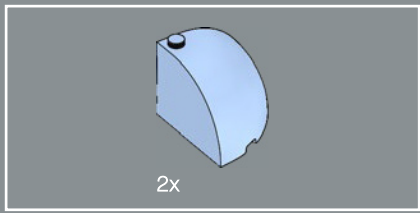

234

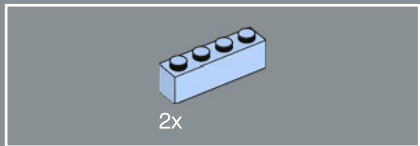
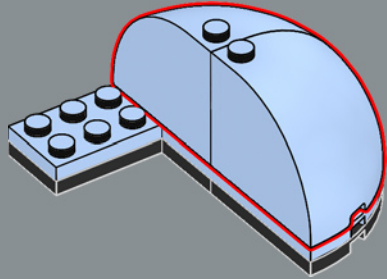

235

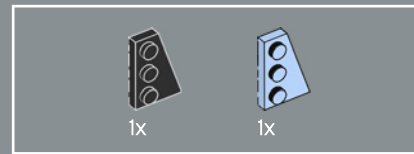
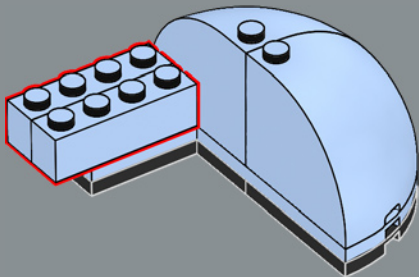

236

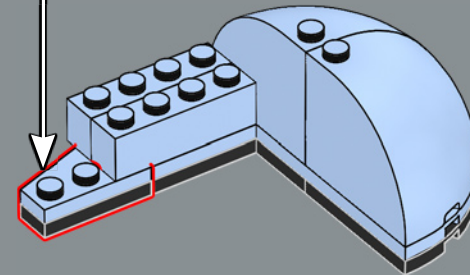
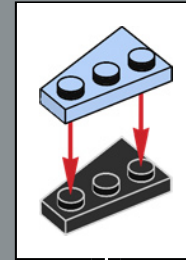

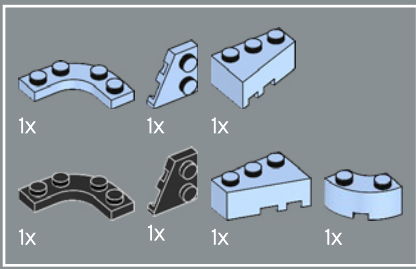

237

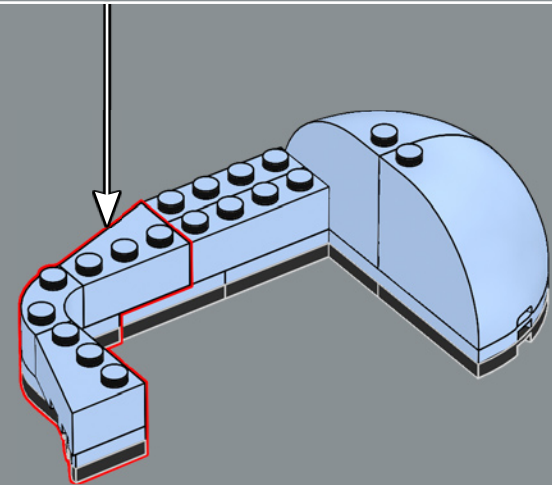
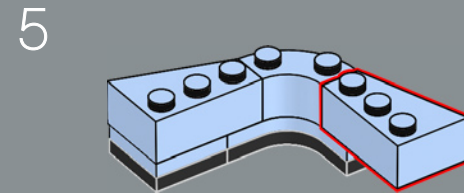
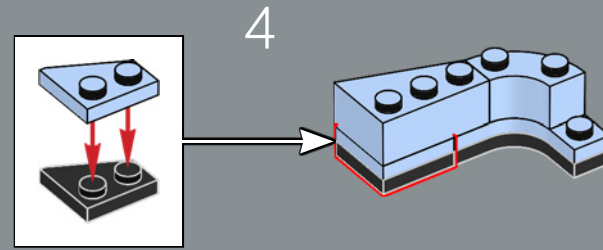
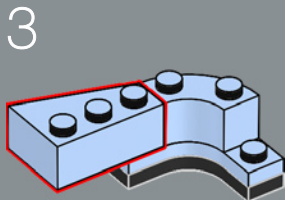
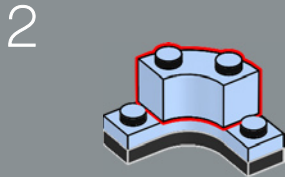
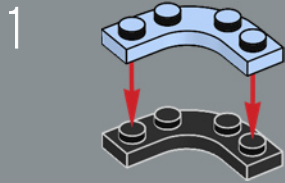

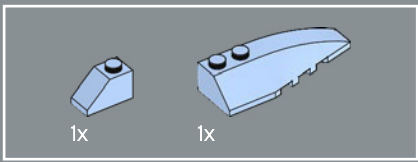

238

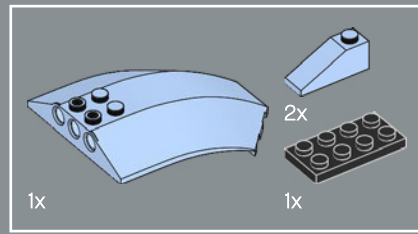
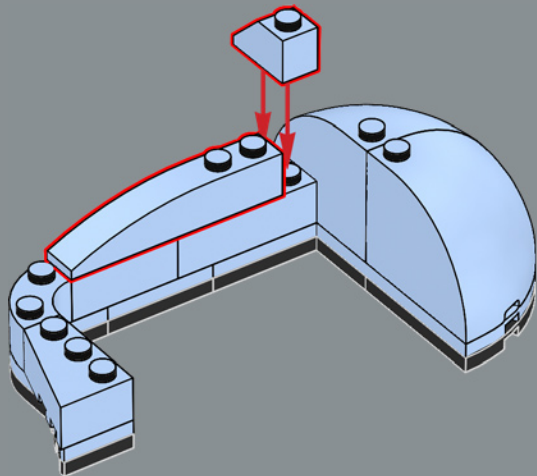

239

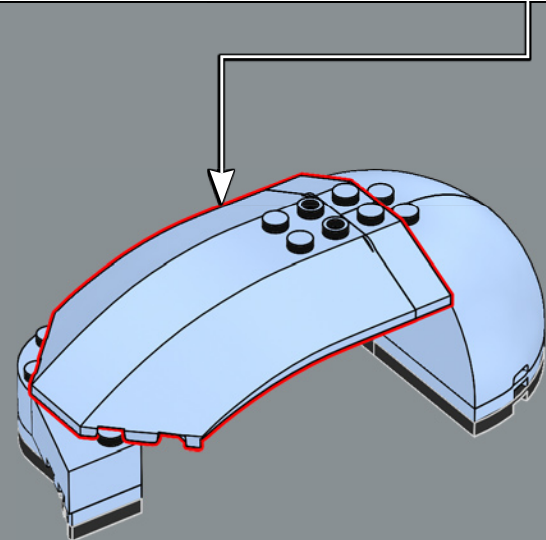
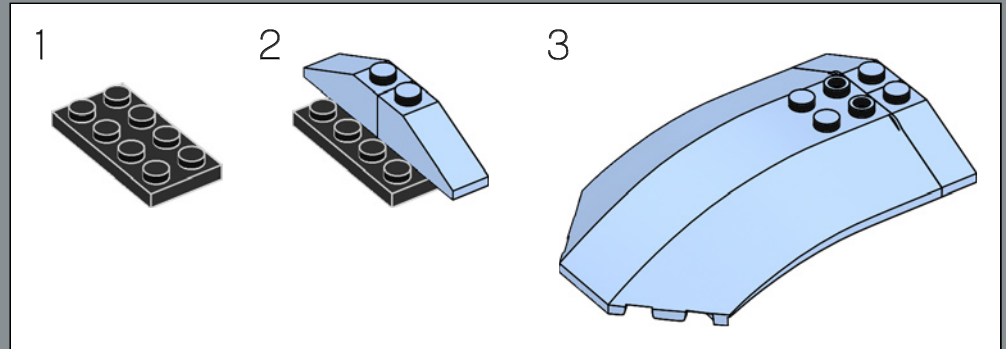

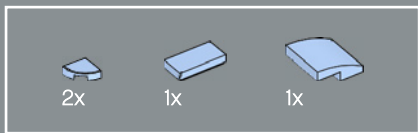

240

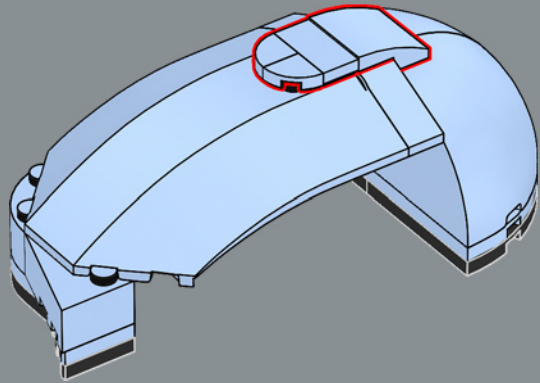

241

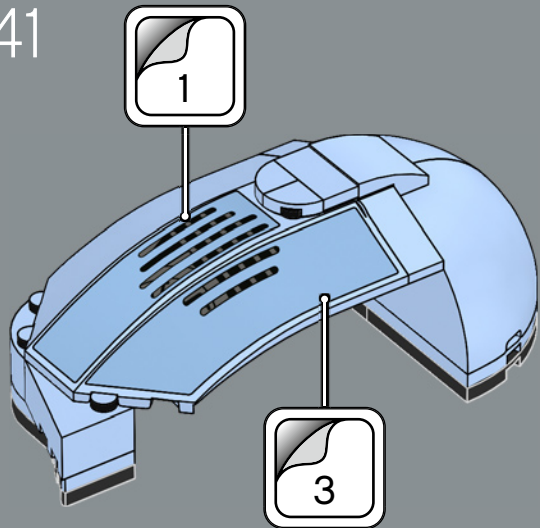

242

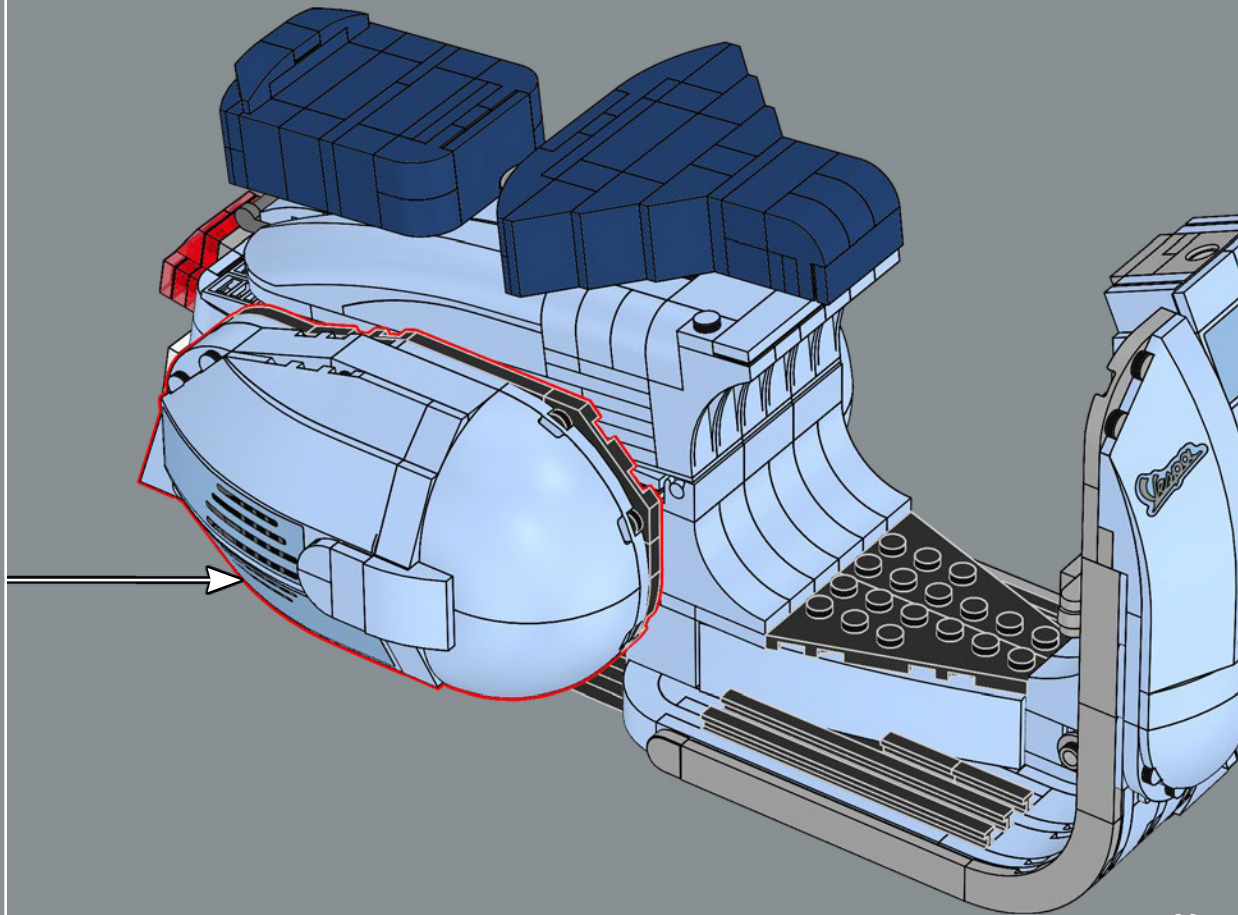

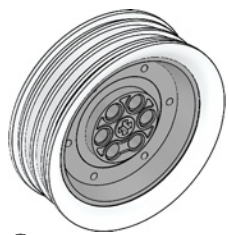

2x



2x

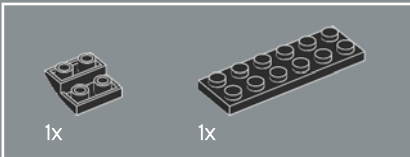
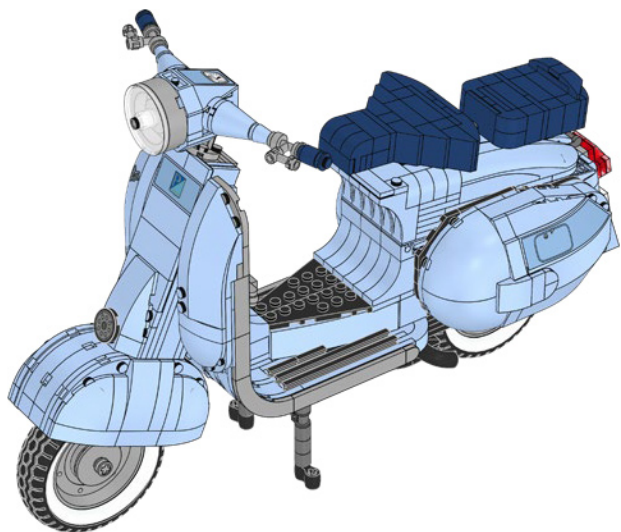
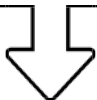

243

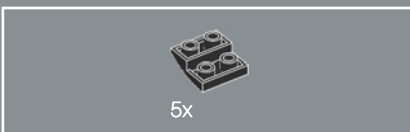
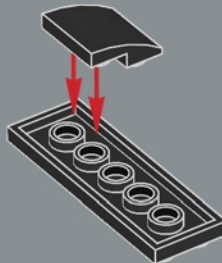

244

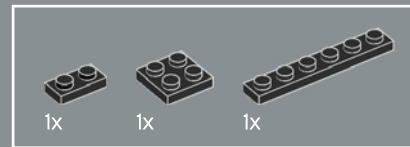
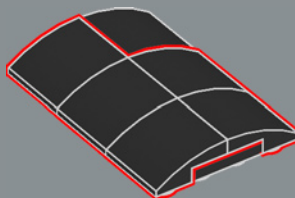

245

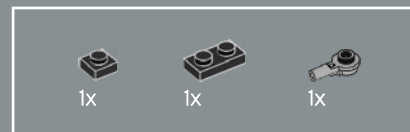
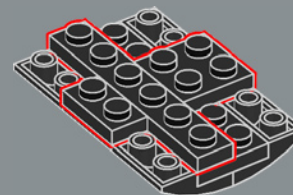

246

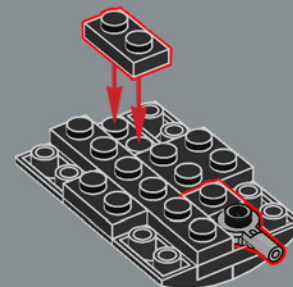

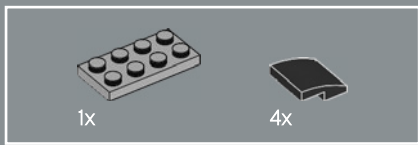

247

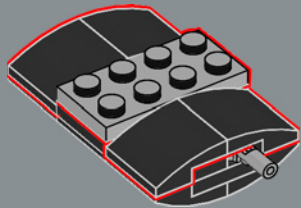

248

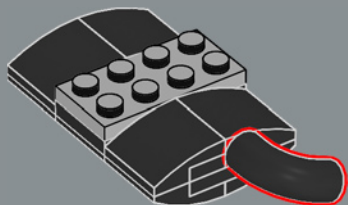

249

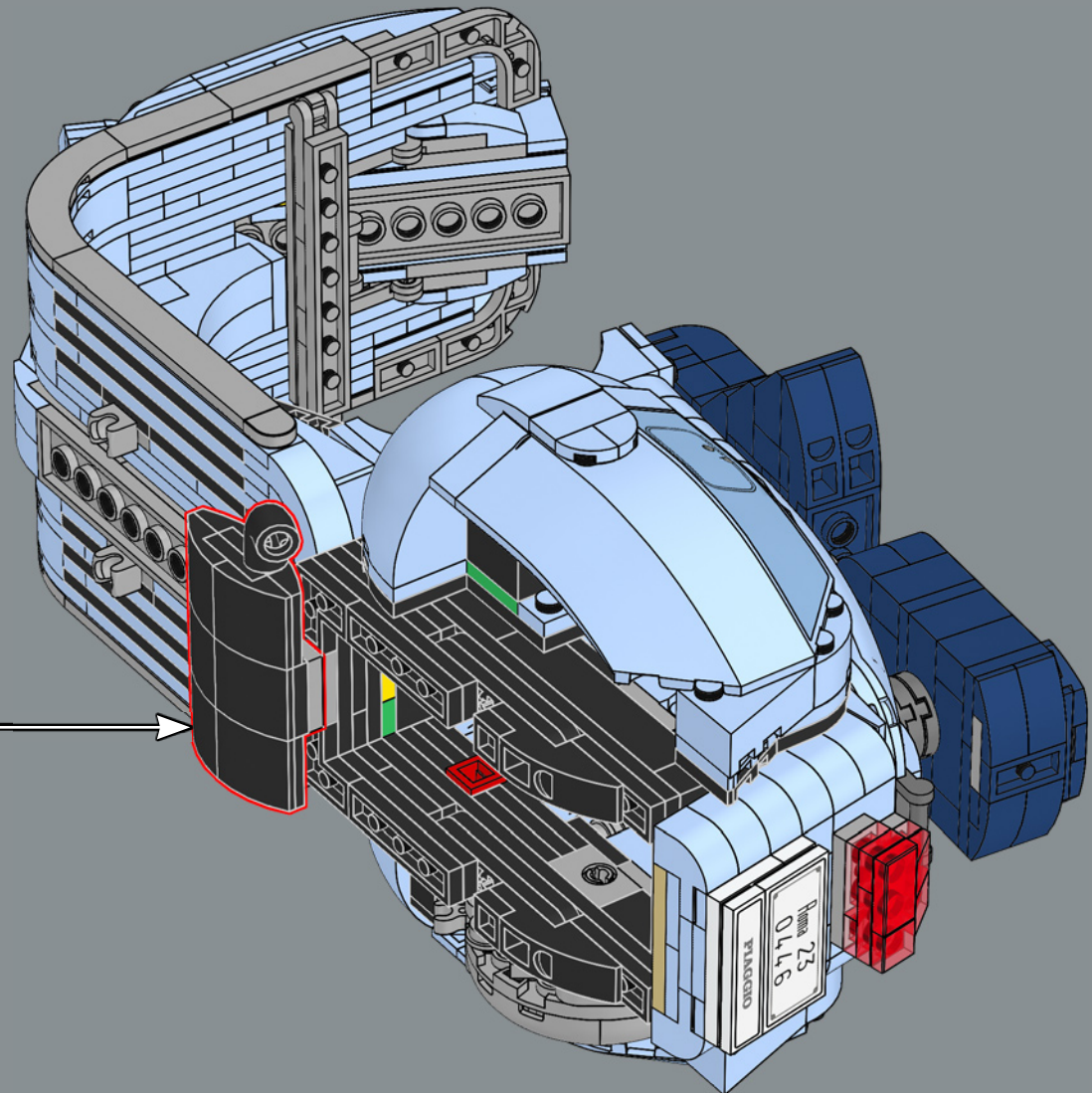

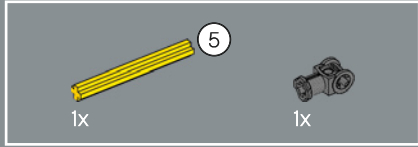
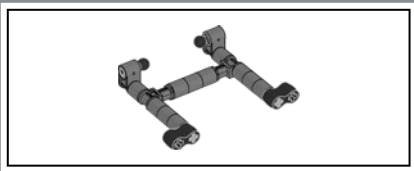

250

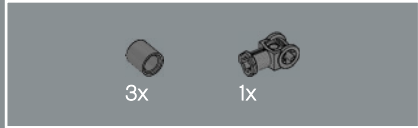
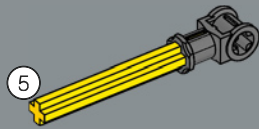

251

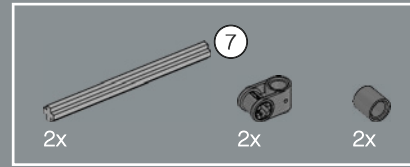
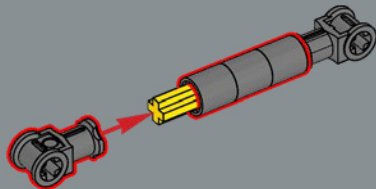

252

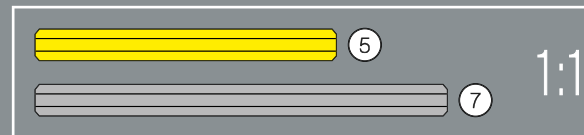
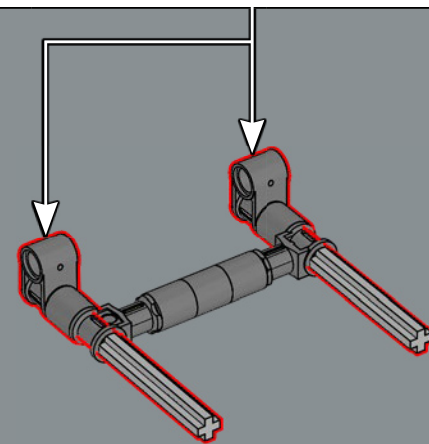
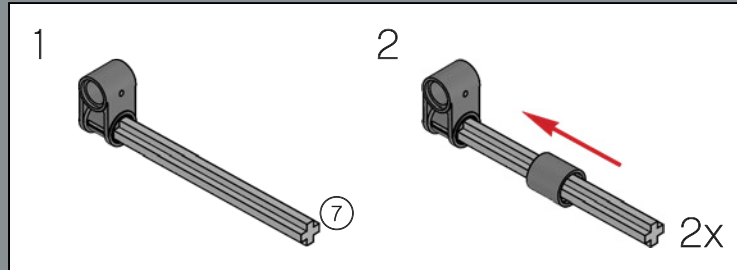



253

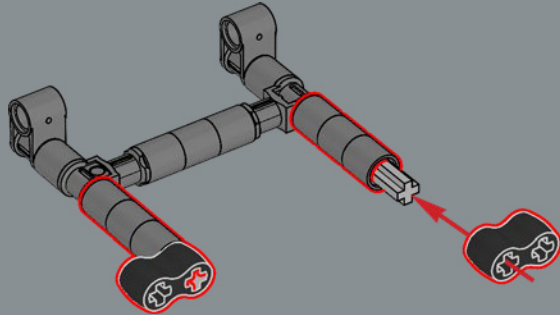

254

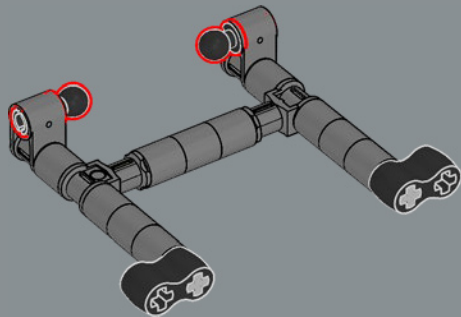

255

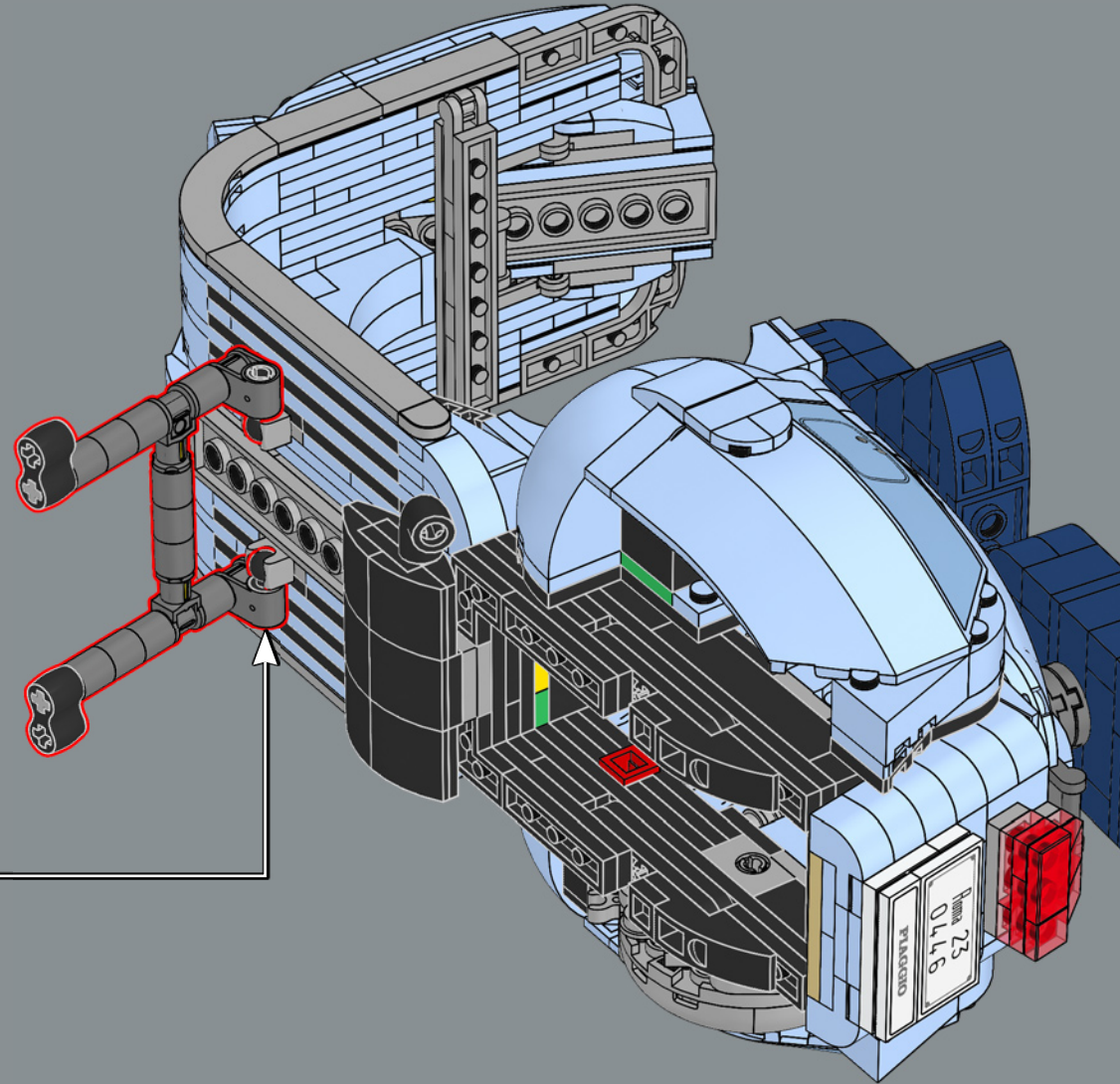

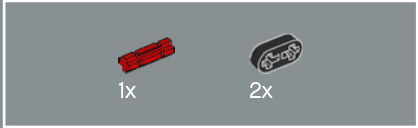
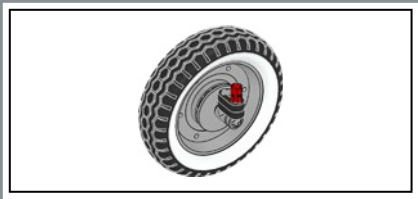

256

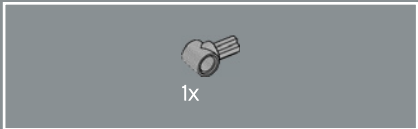

257

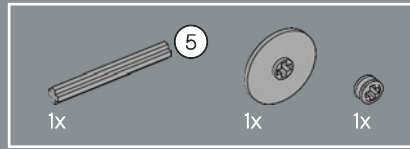

258

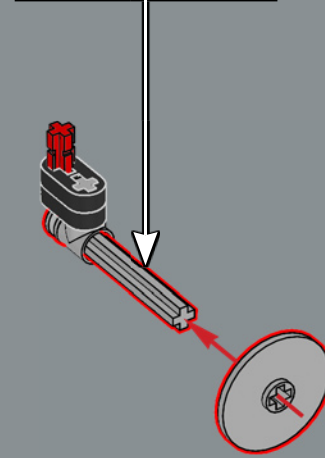
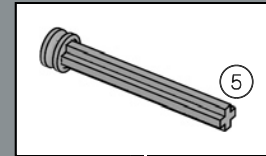

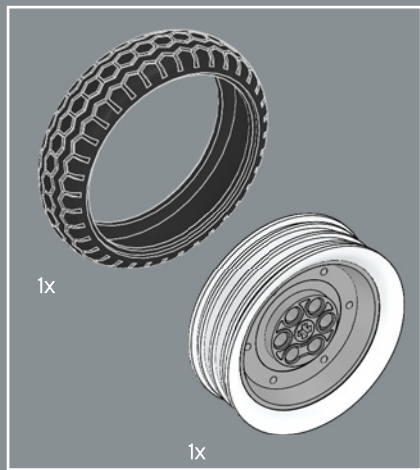

259

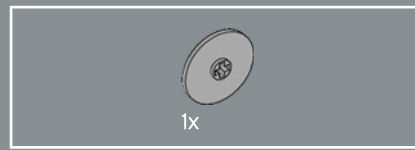
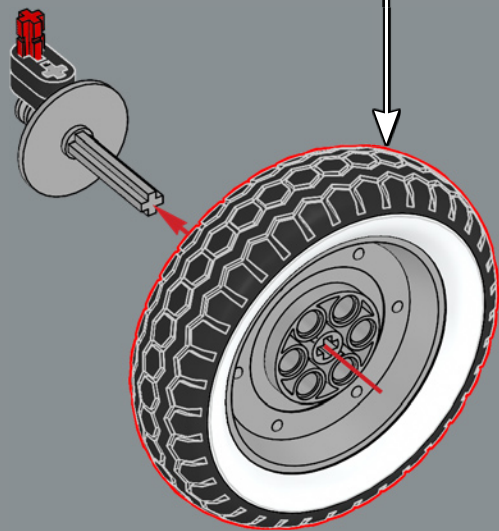
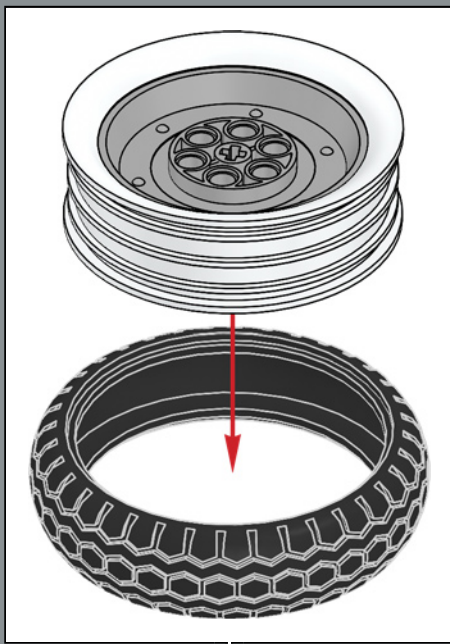

260

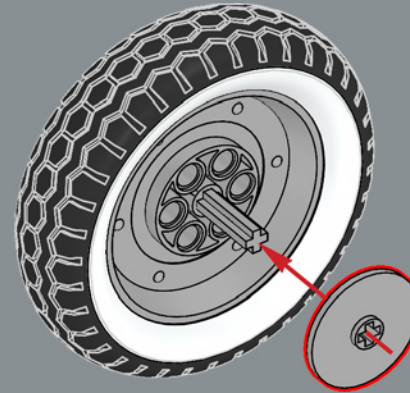

261

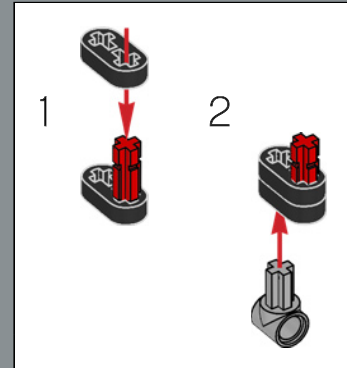
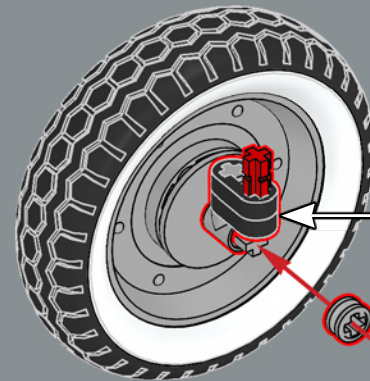

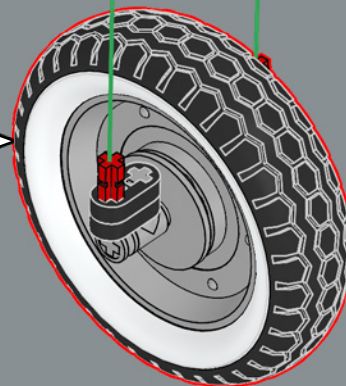
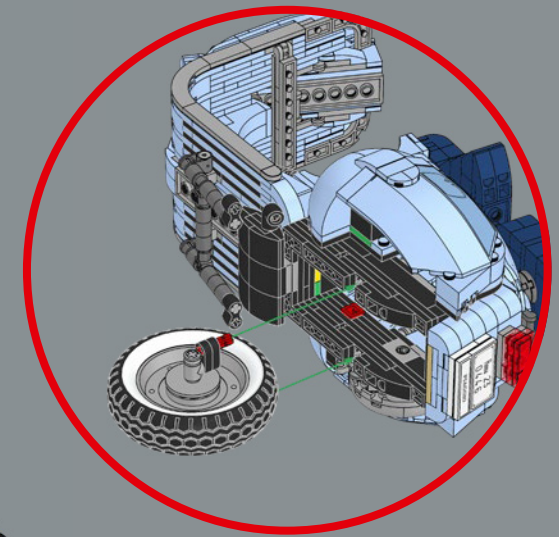
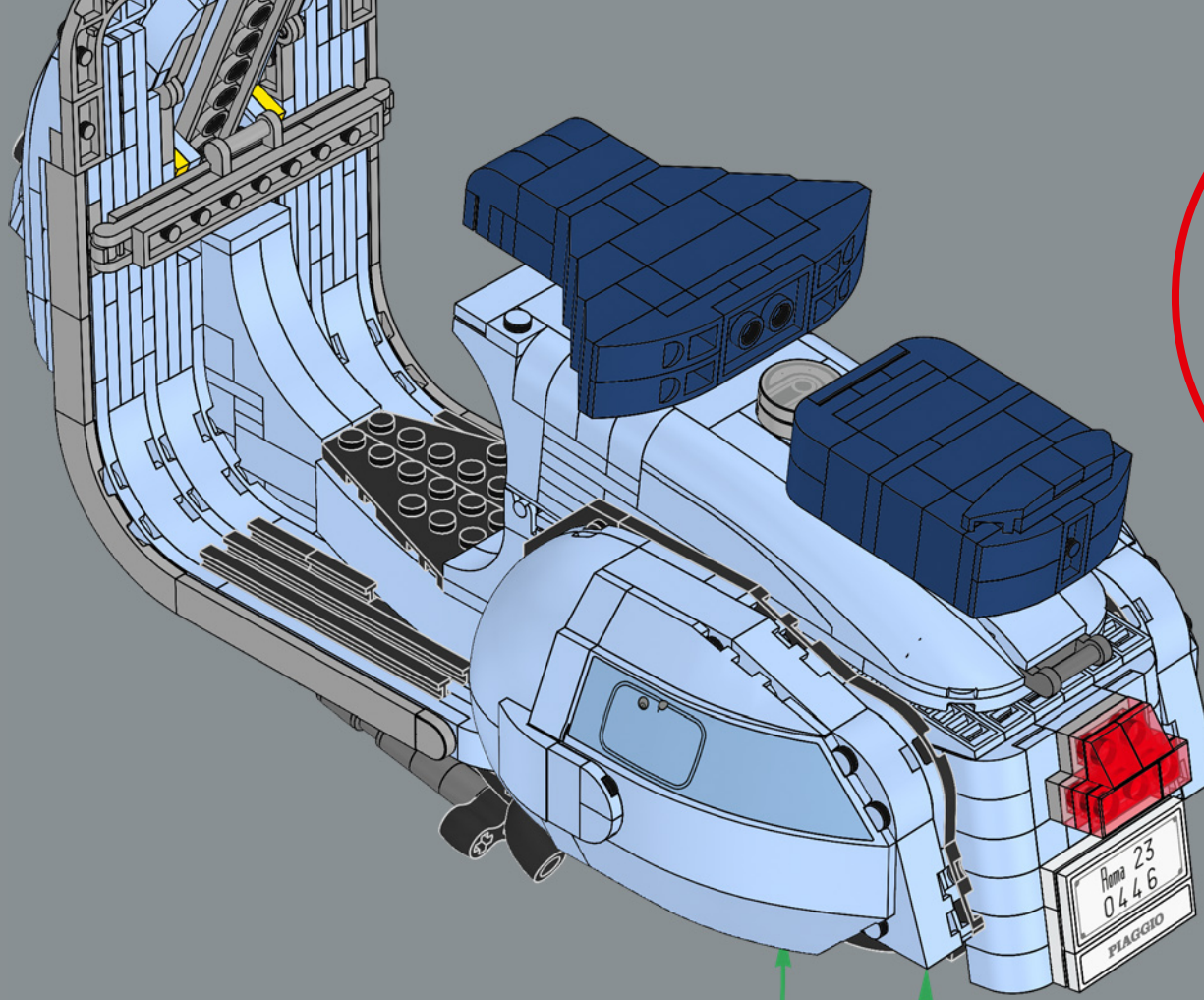

It's the first time in LEGO® history that we have a two-color wheel with the white outer wall on the black tire.

Avec ses pneus noirs à flancs blancs, ce modèle est le premier dans l'histoire de LEGO® à présenter des roues bicolors.

Es la primera vez en la historia de LEGO® que empleamos una rueda bicolor, con llanta negra de banda exterior blanca.

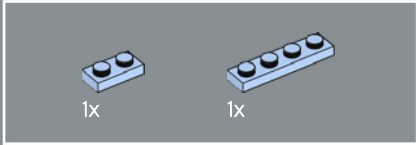
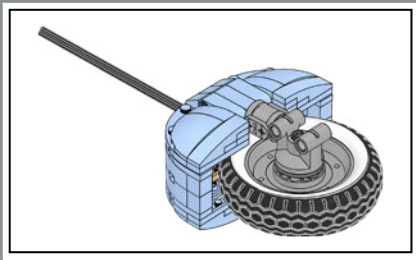

263

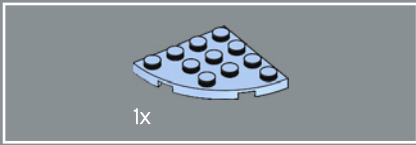
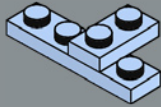

264

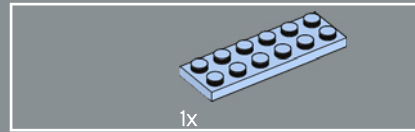
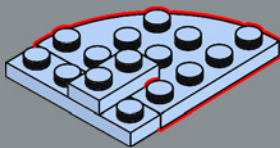

265

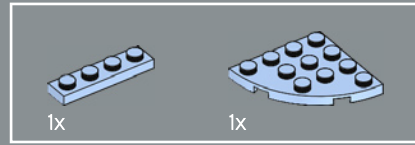
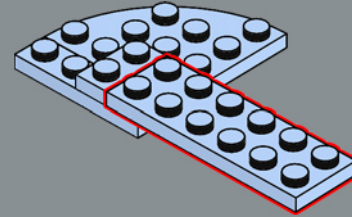

266

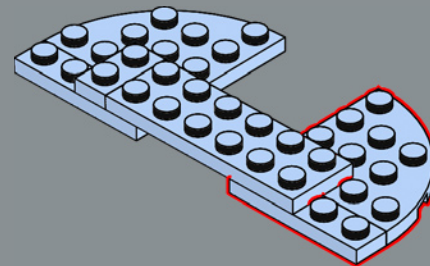

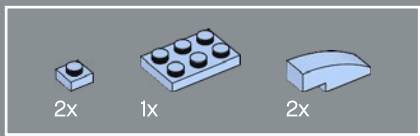

267

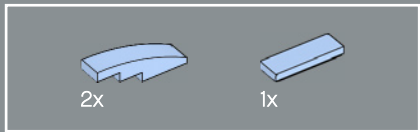
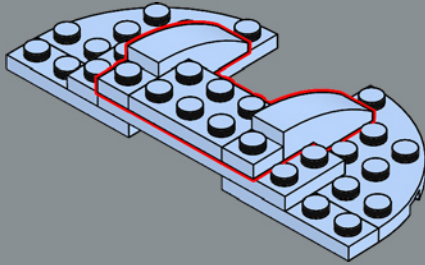

268

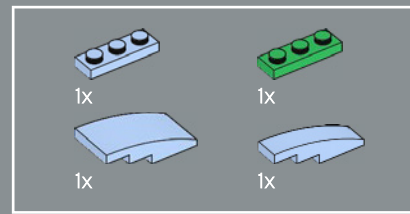
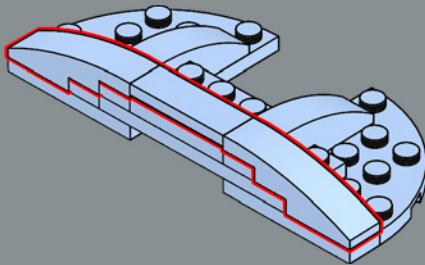

269

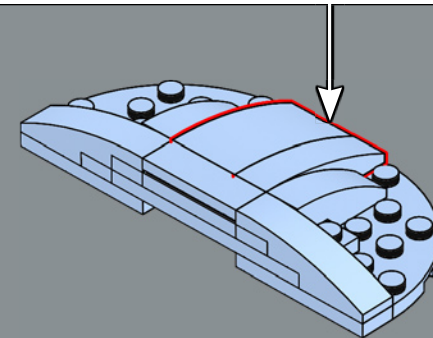
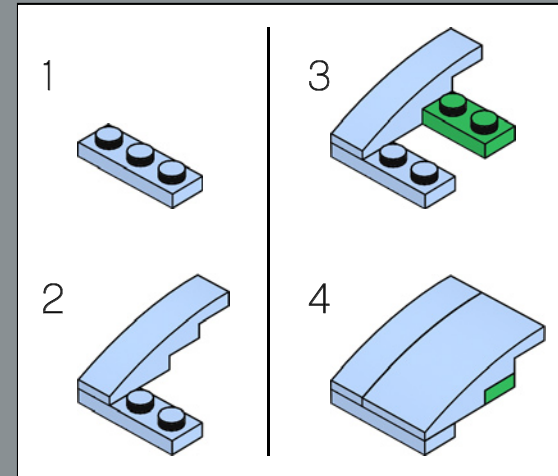



270

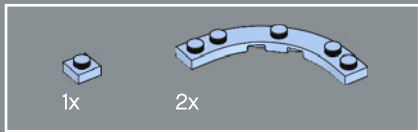
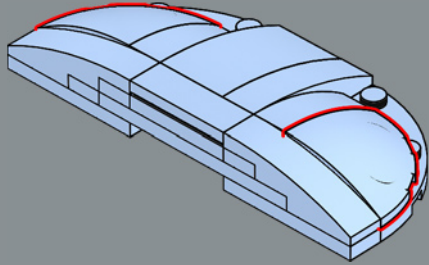

271

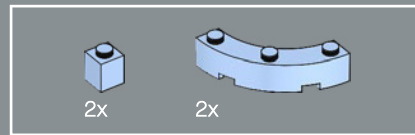
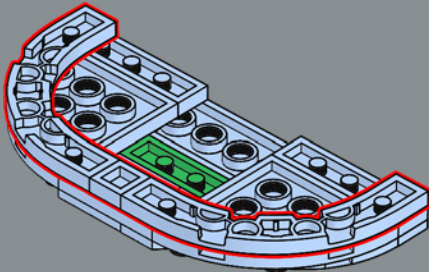

272

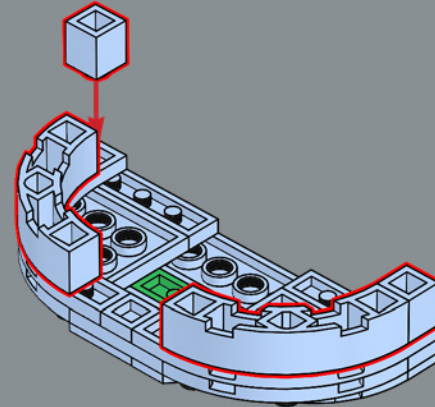

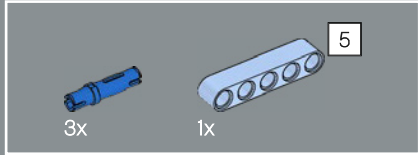
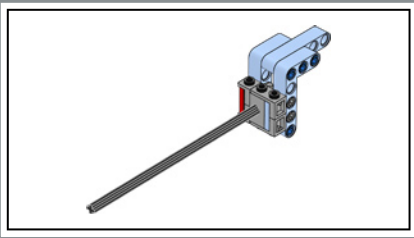

273

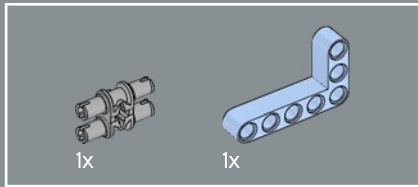
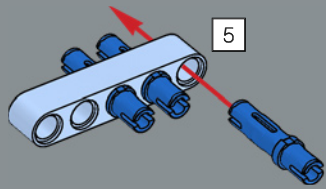

274

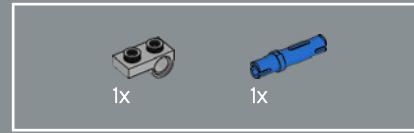
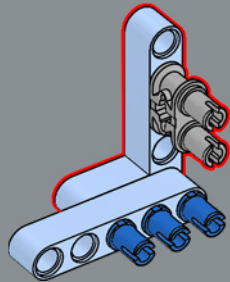

275

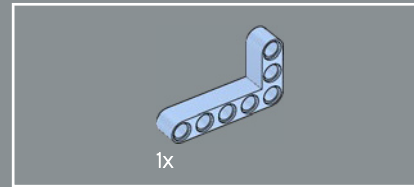
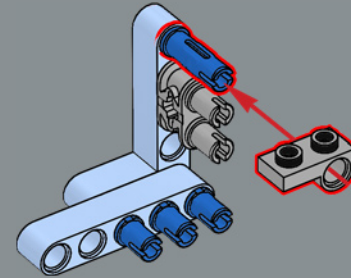

276

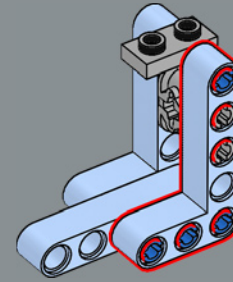

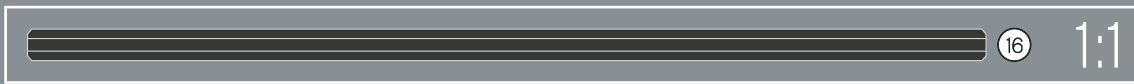
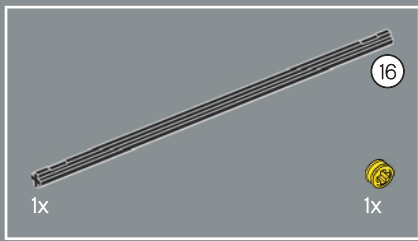

277

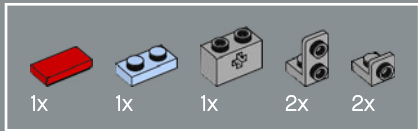
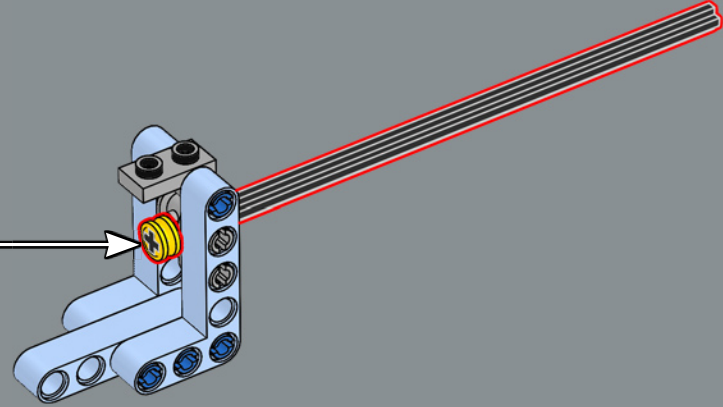
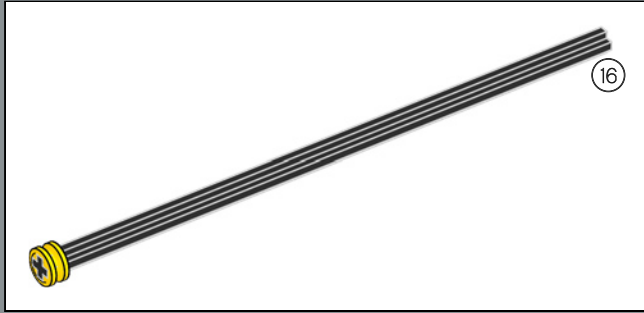

278

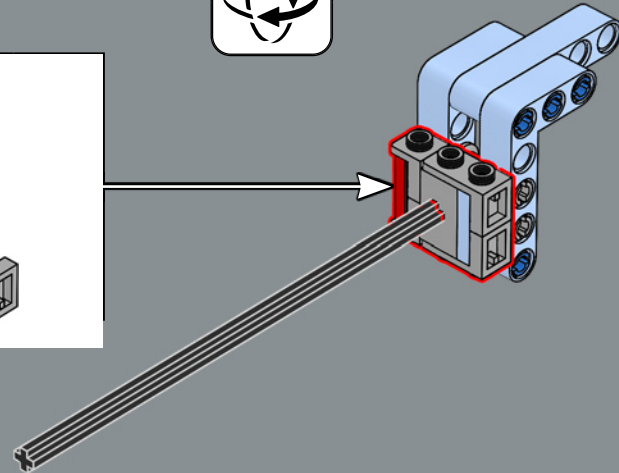
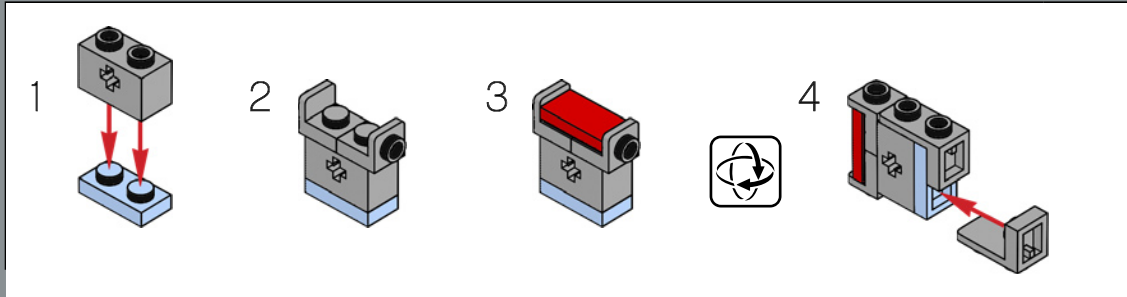

279

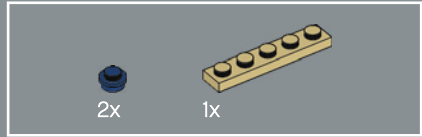
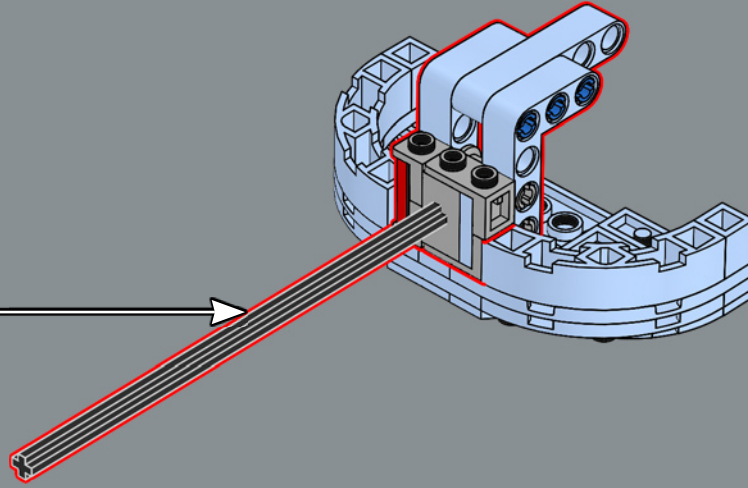

280

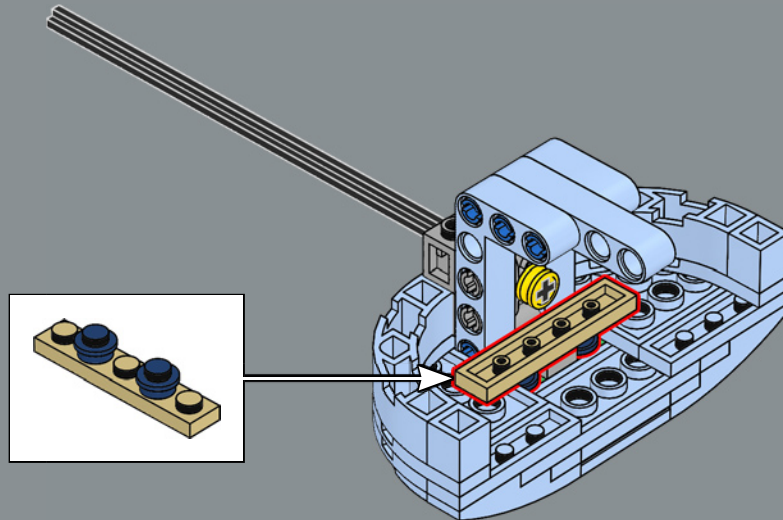

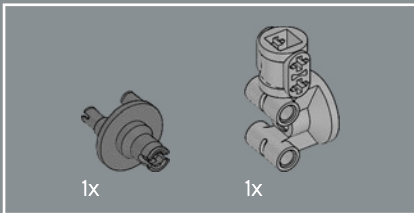

281

CLICK KLICK
CLIC CLIQUE
KATT KLIKŠKIS
咔嗒

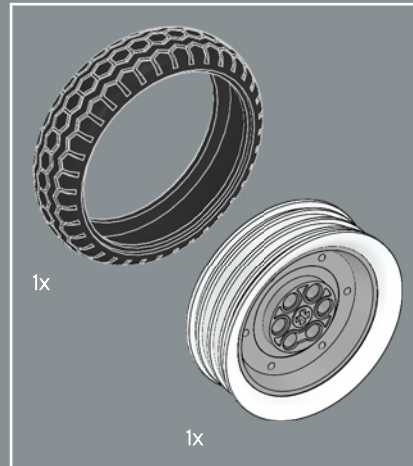
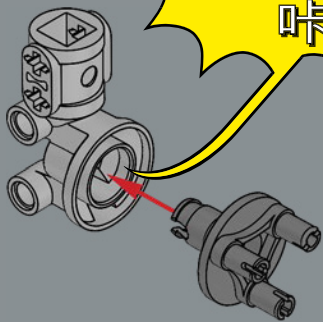

282

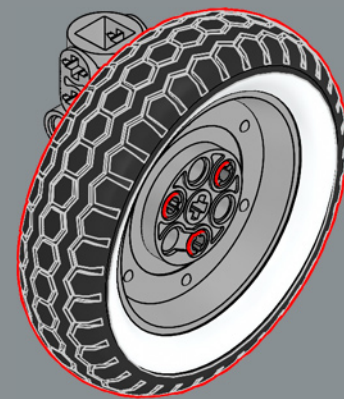
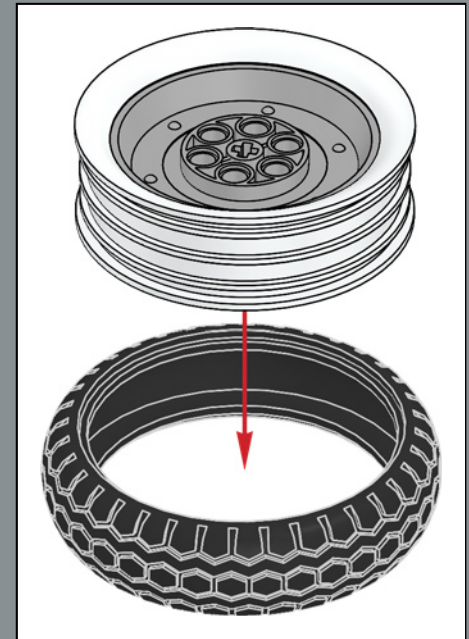

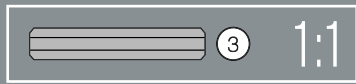
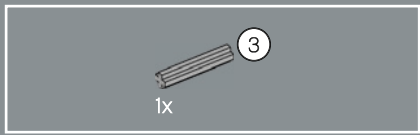

283

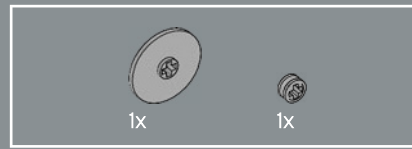
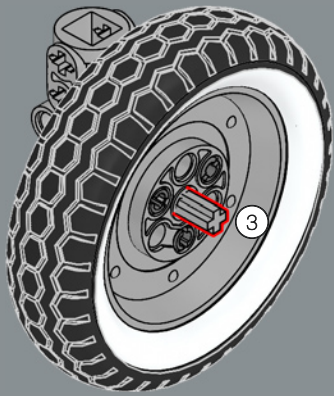

284

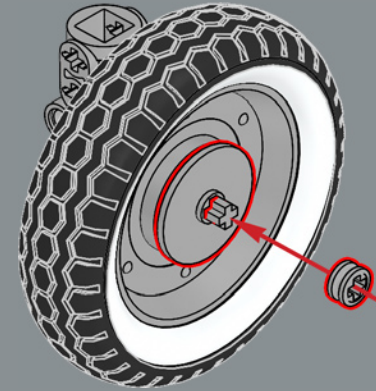

285

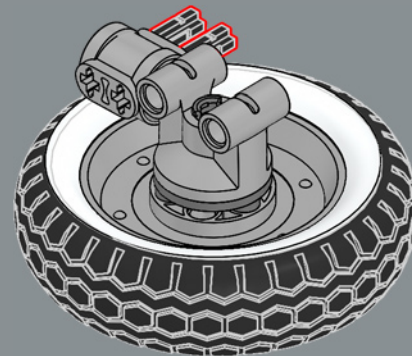

286

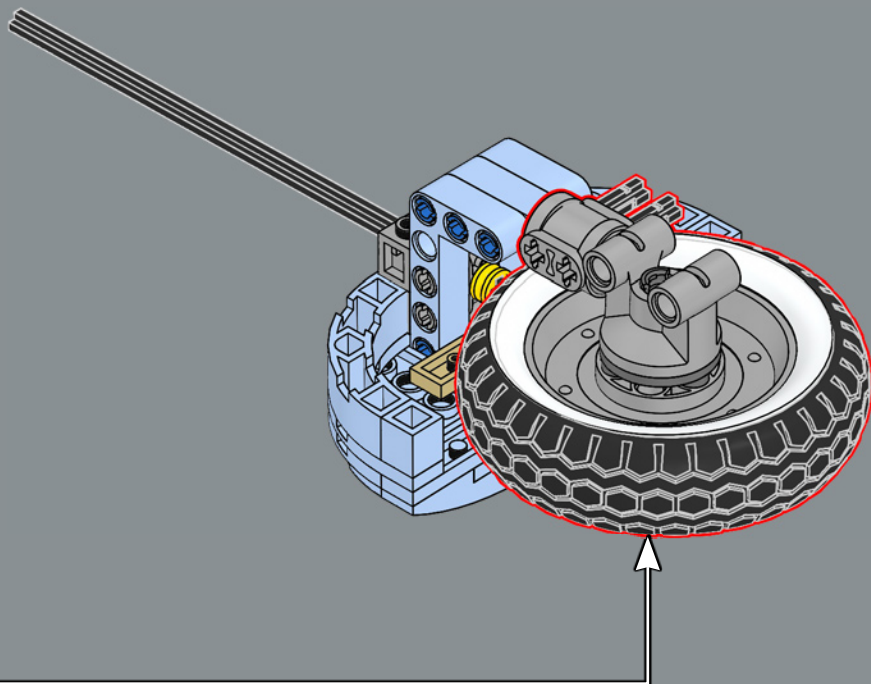

287

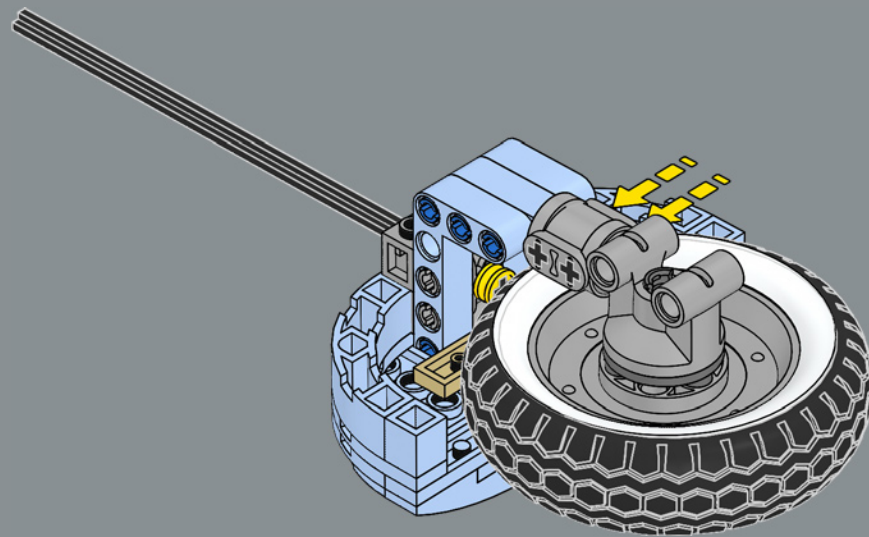

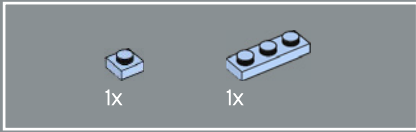
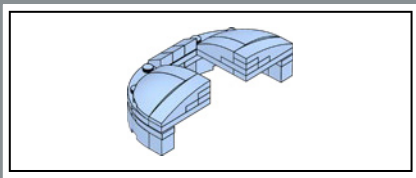

288

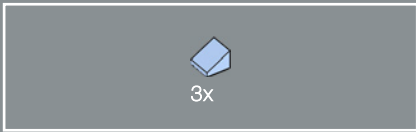
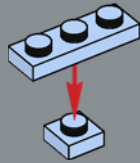

289

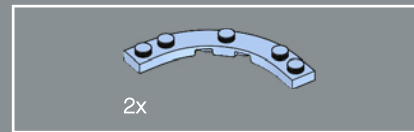
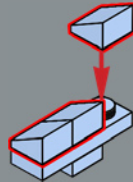

290

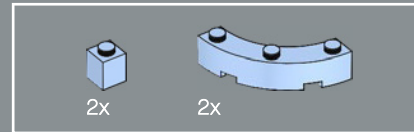
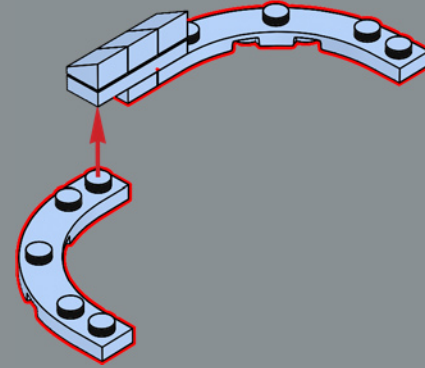

291

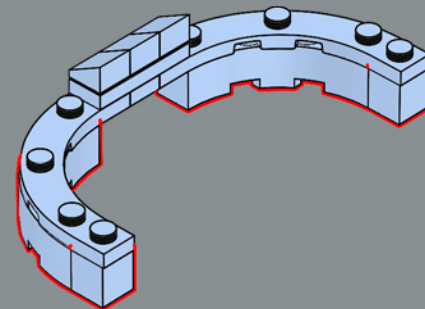

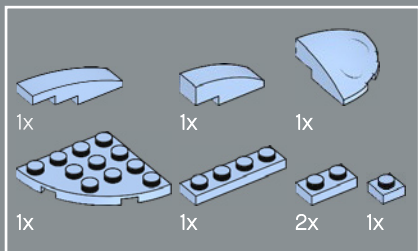

292

1

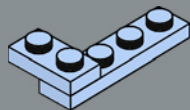

2

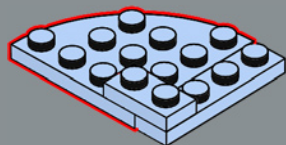

3

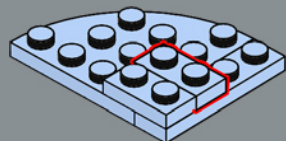

4

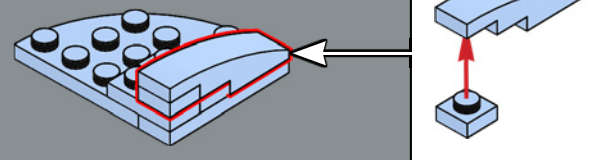

5

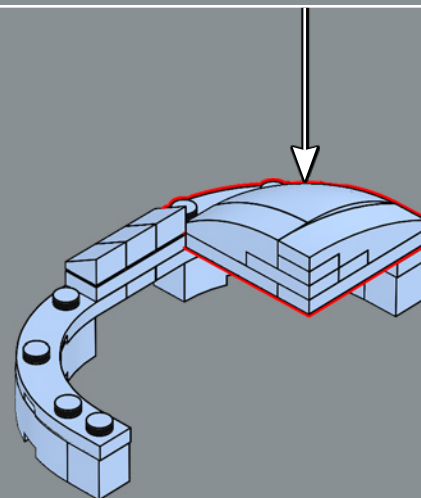
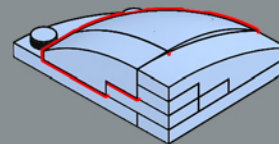

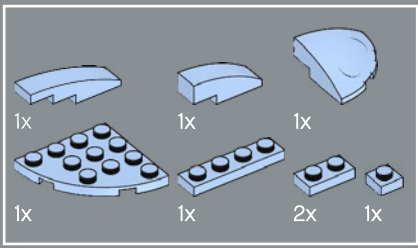

293

1

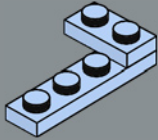

2

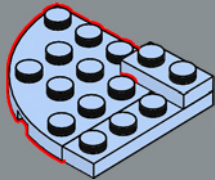

3

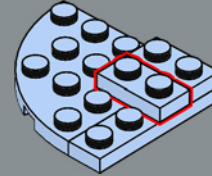

4

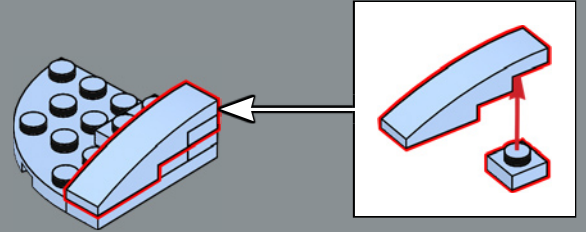

5

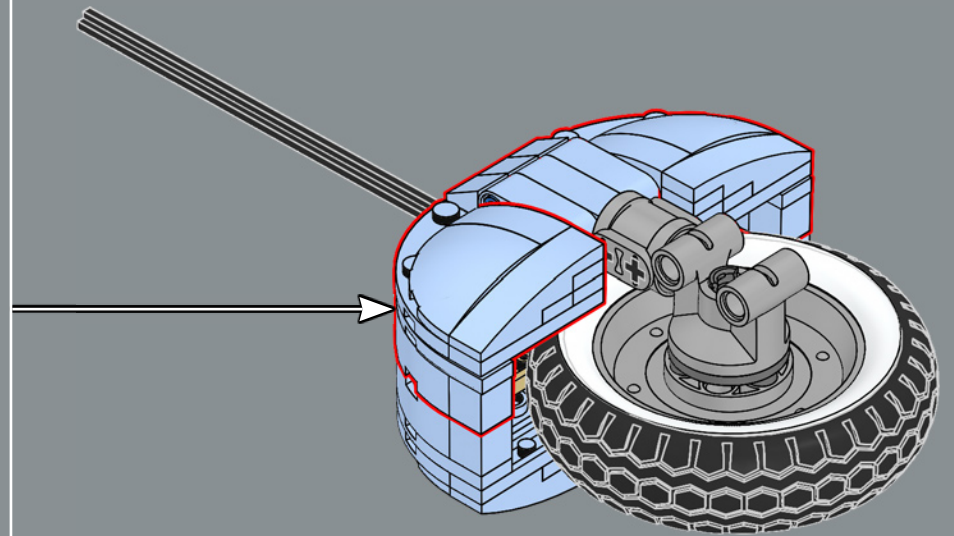
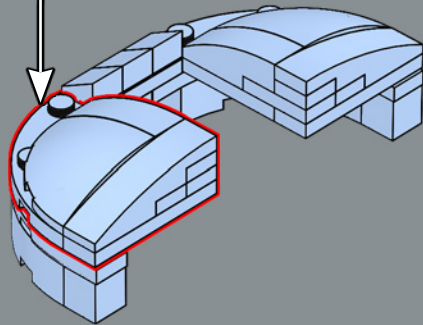
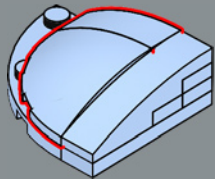



1x

294

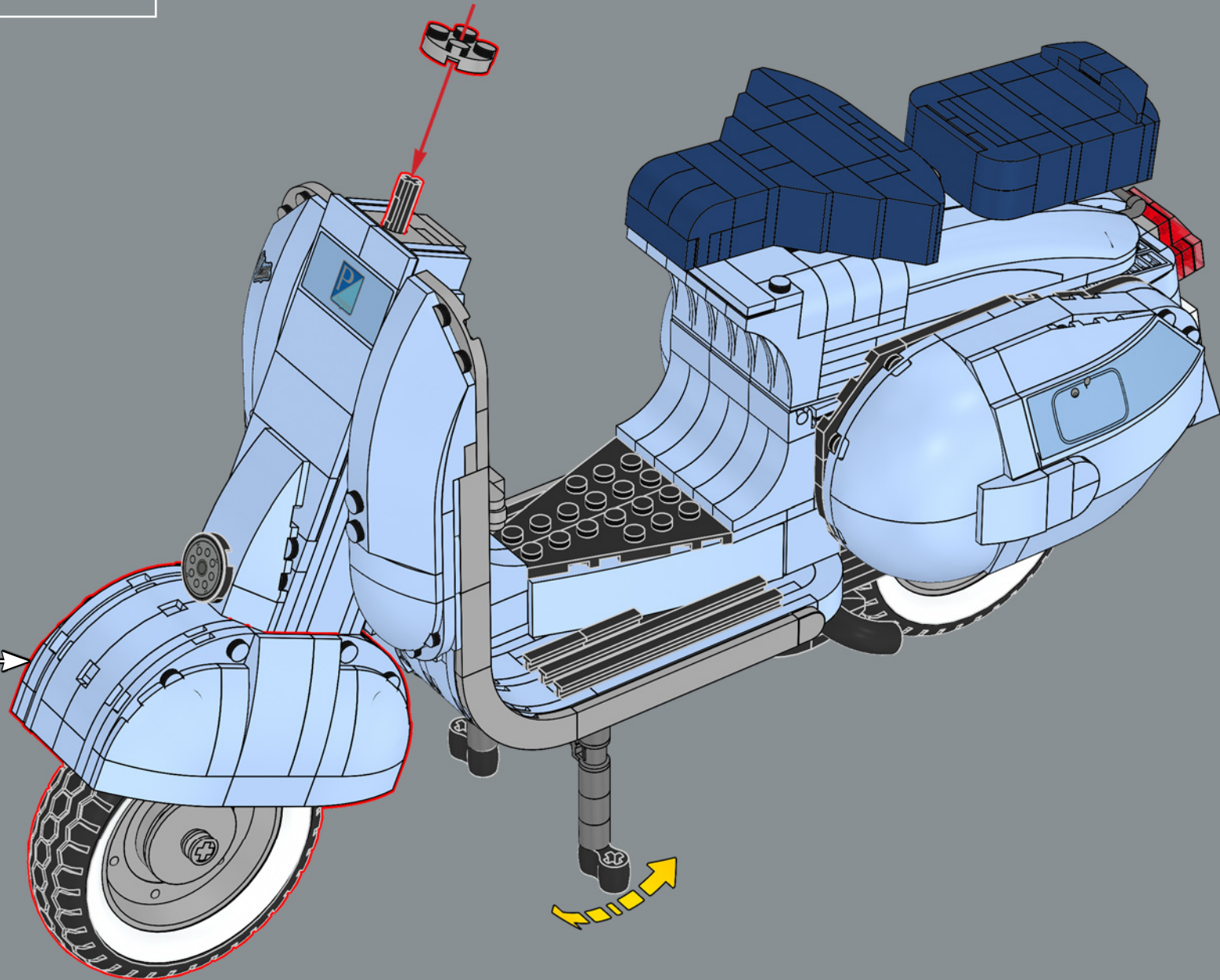

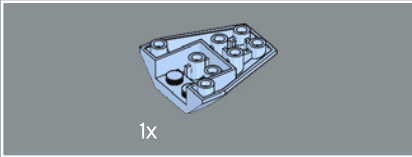
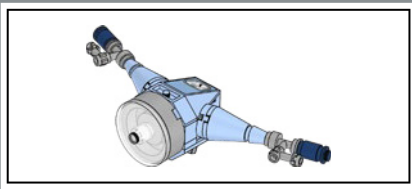

1x

295

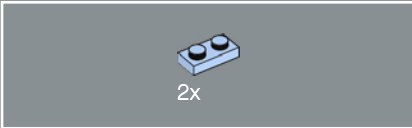
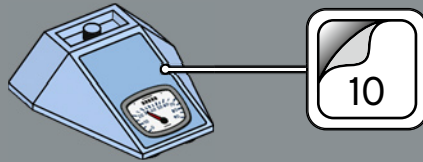

2x

296

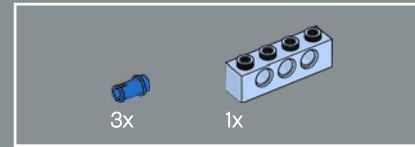
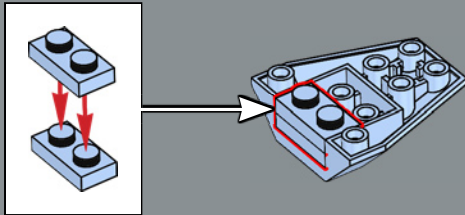

3x

1x

297

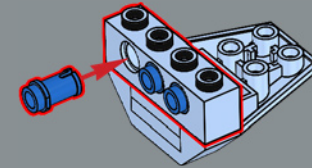

2x

2x

298

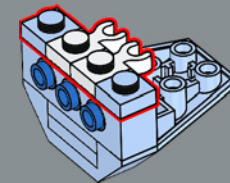

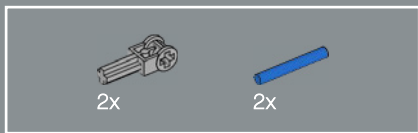

299

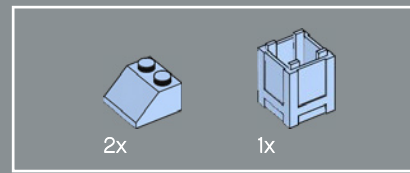
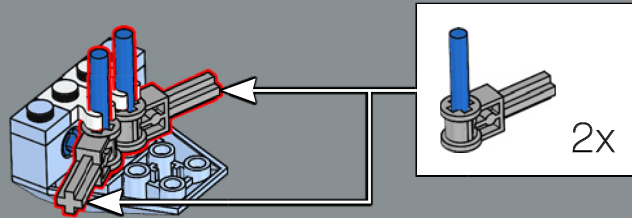

301

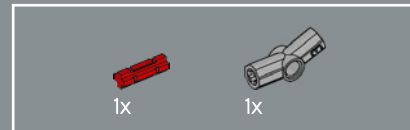
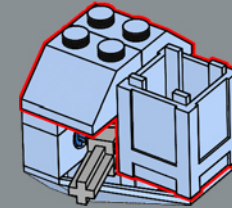

302

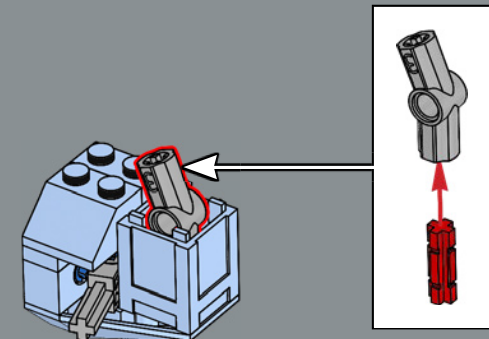

300

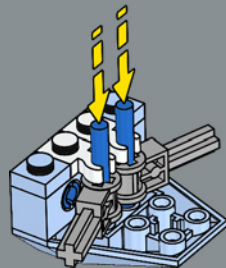

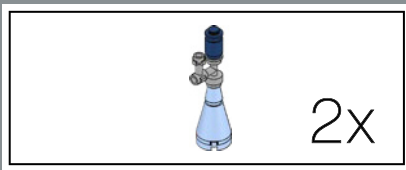

303

1

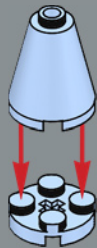

2

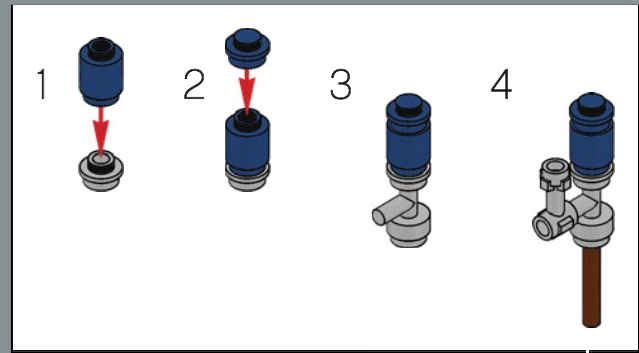

3

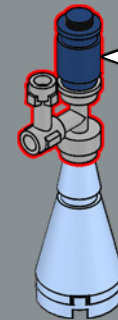

2x

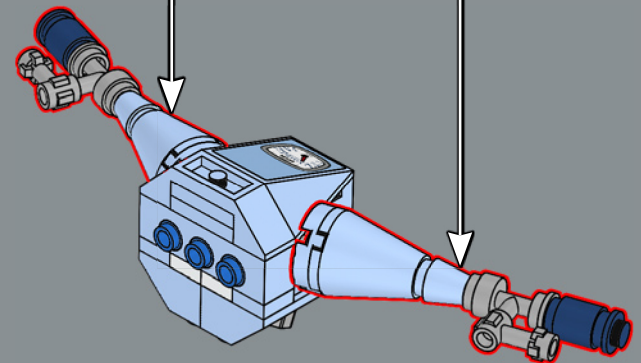

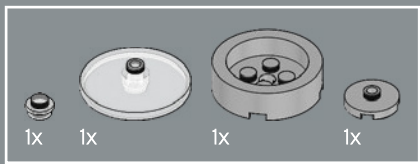

304

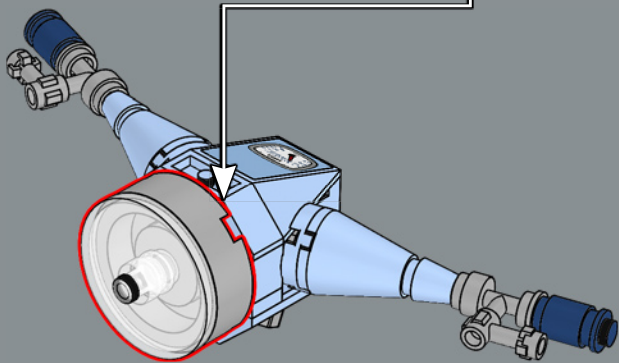
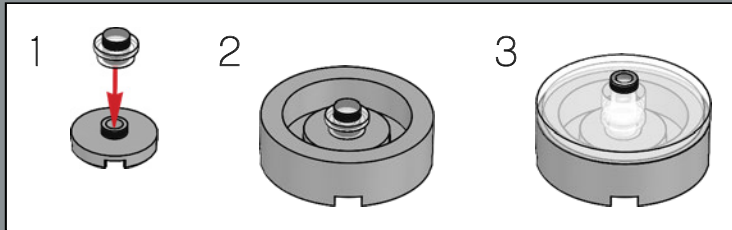

305

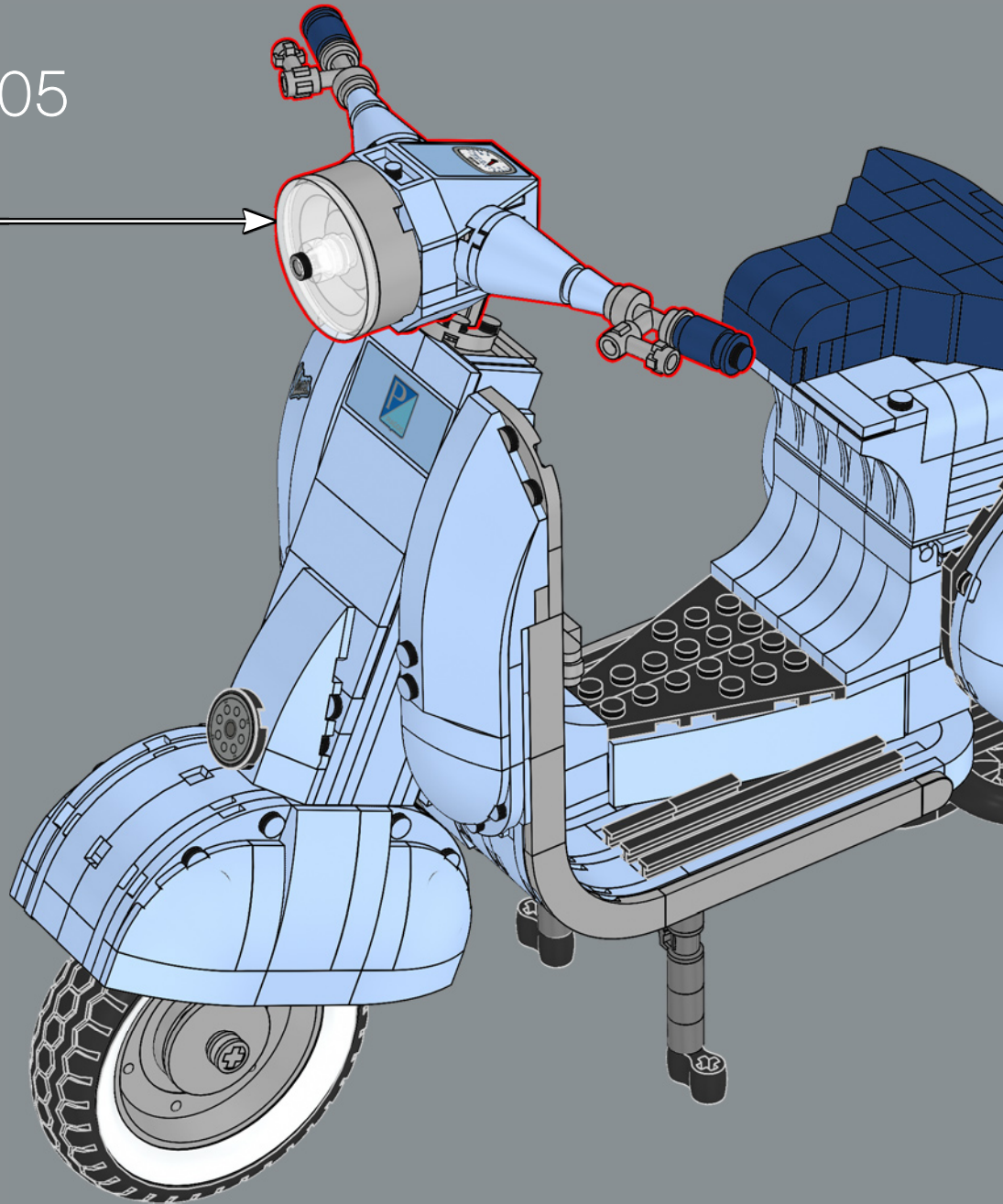

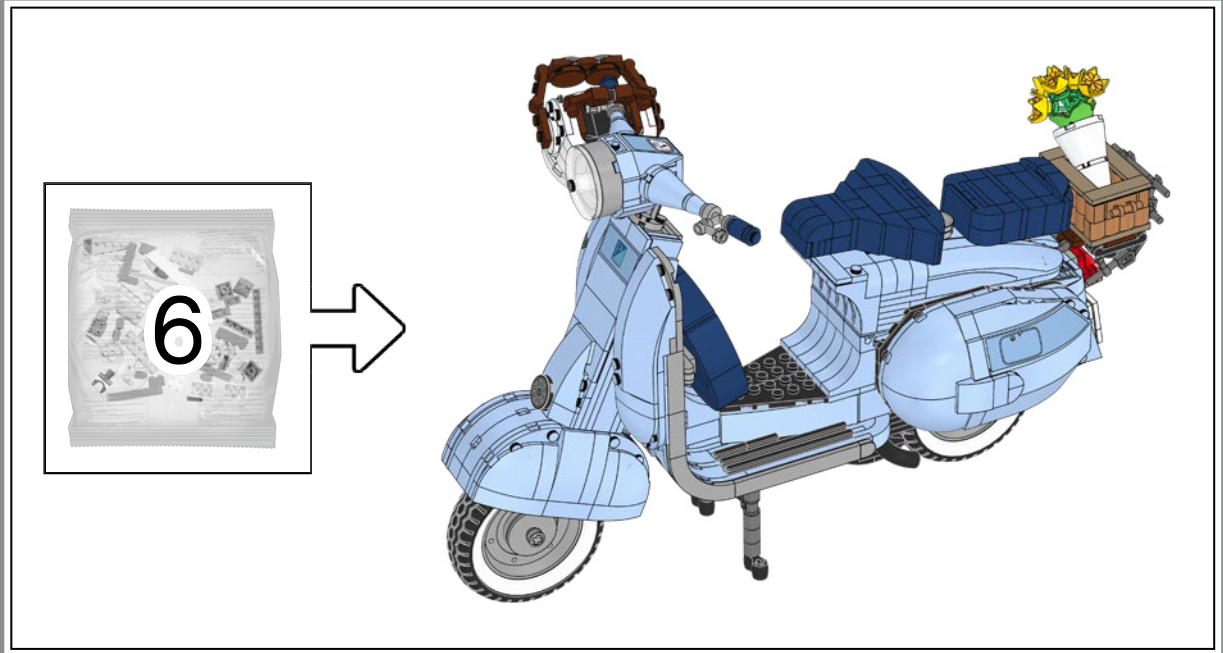
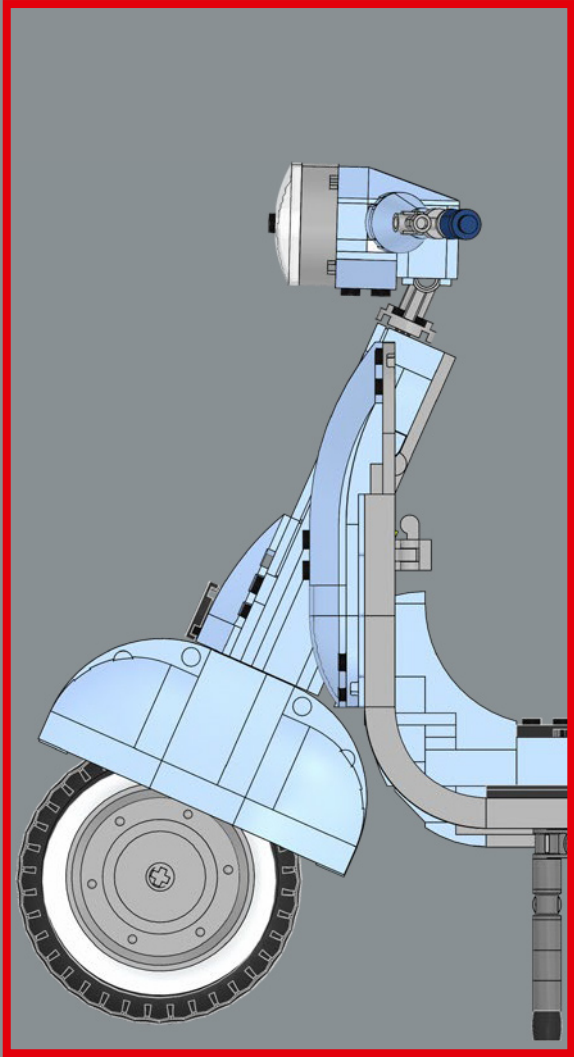



306

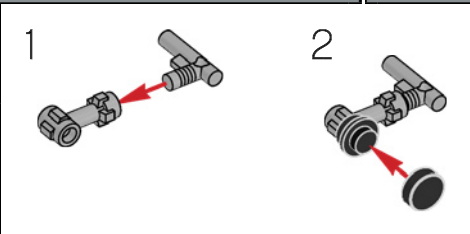
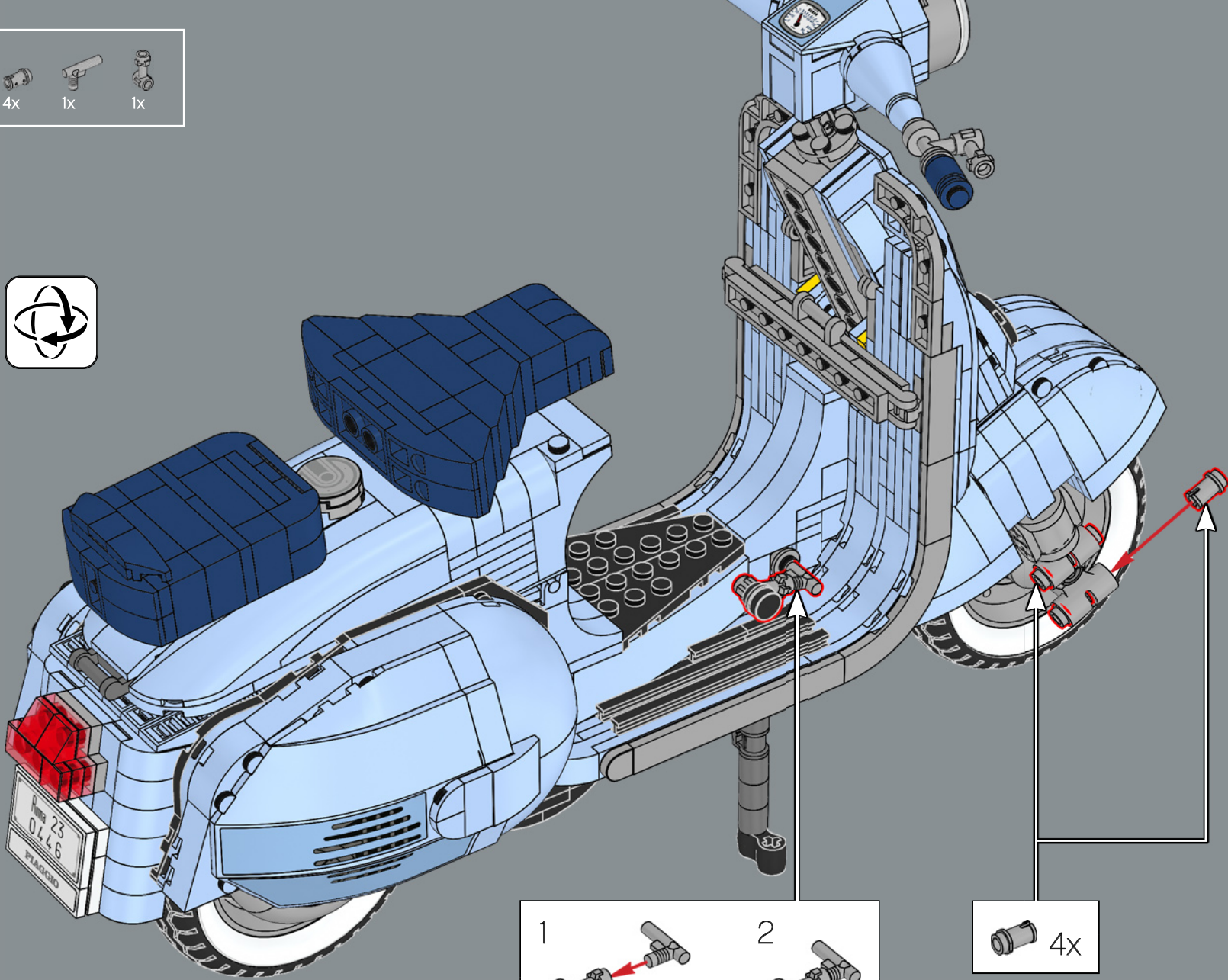

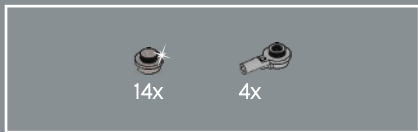

307

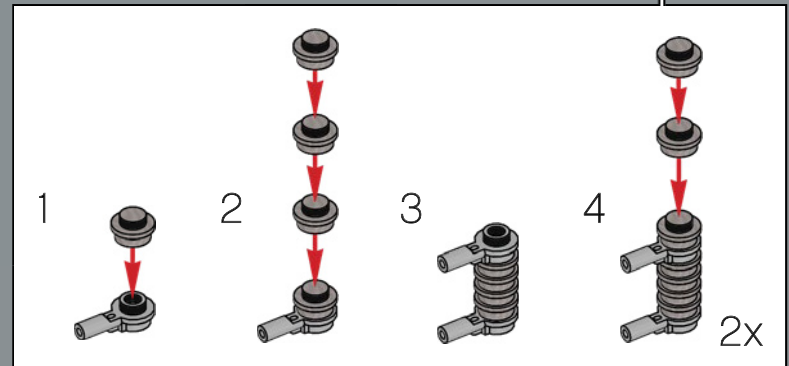
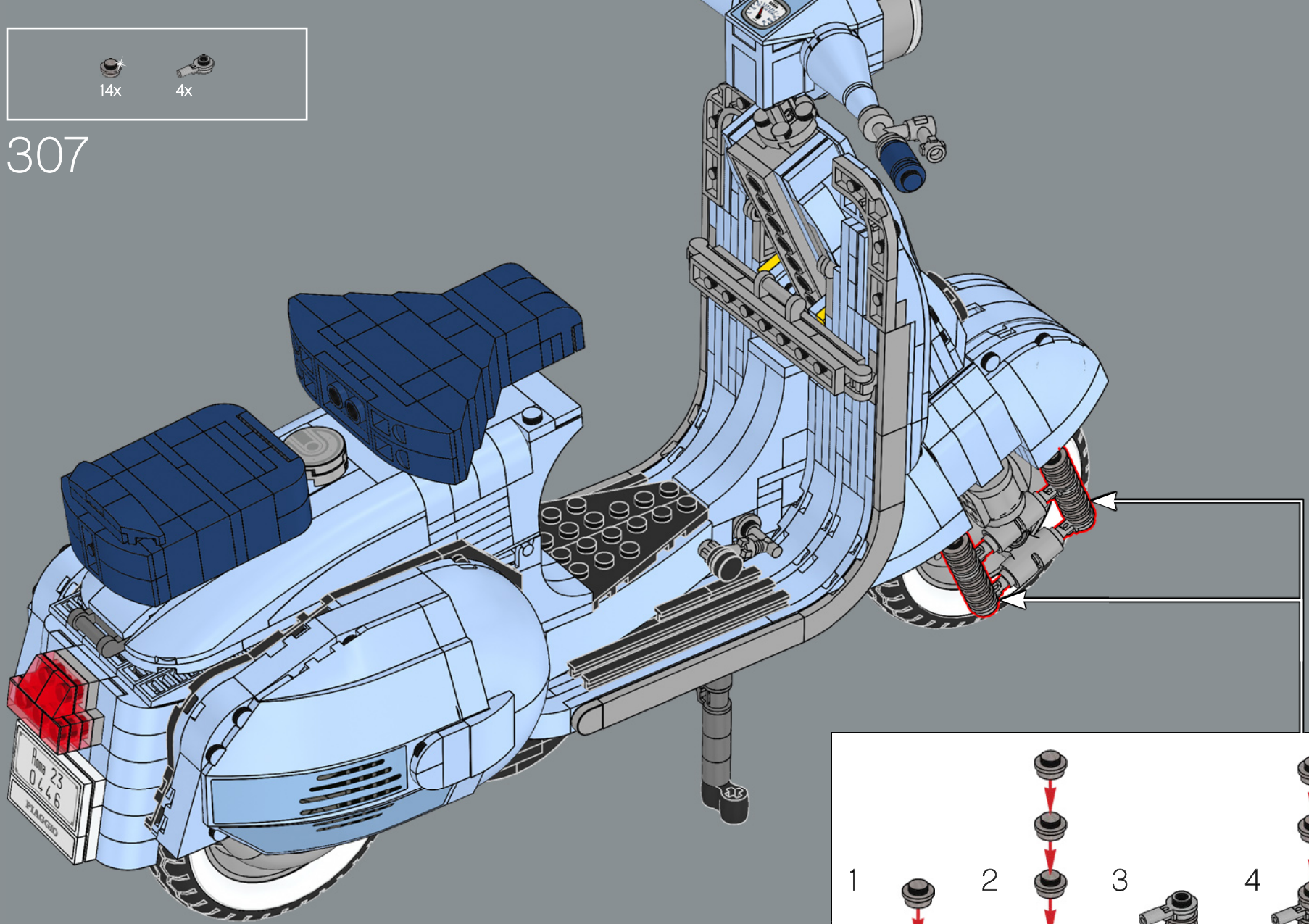

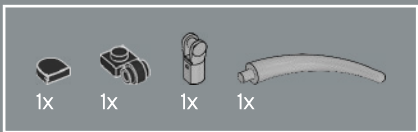

308

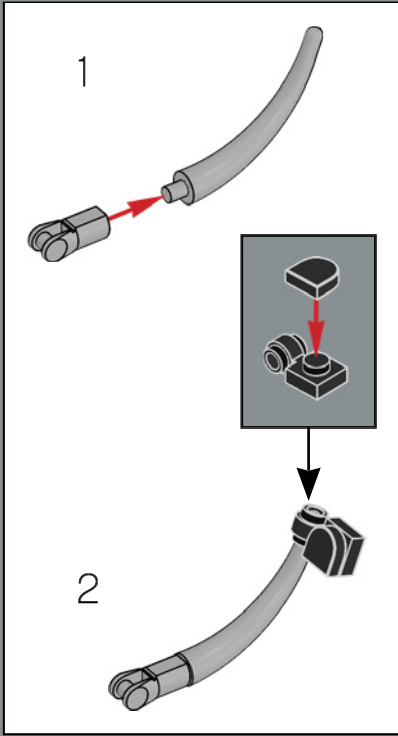
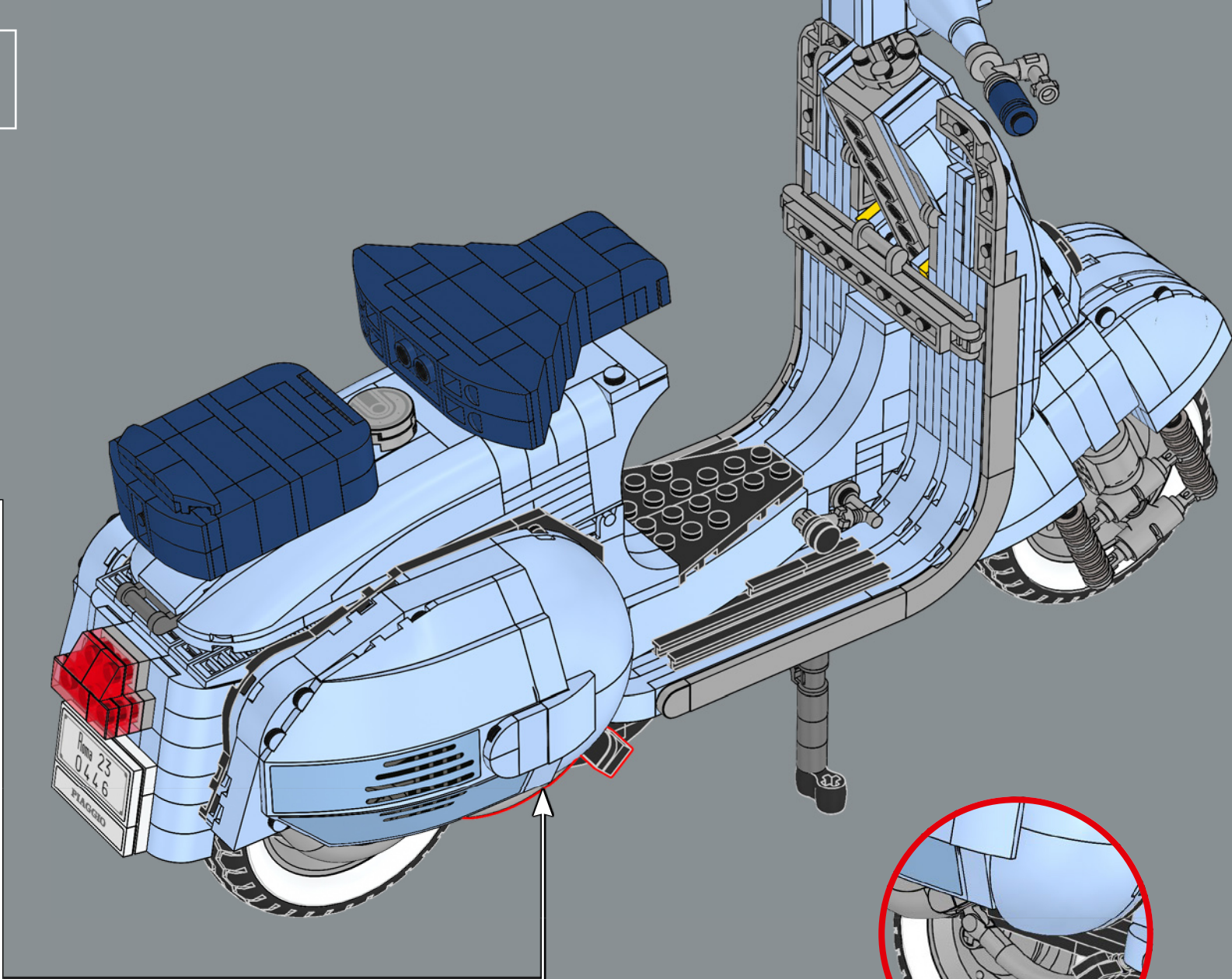

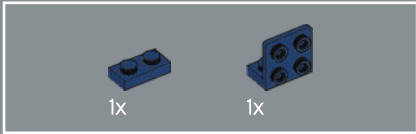
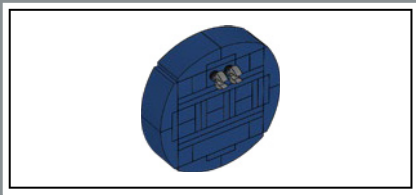

309

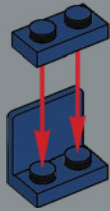

310

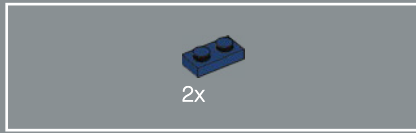
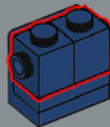

311

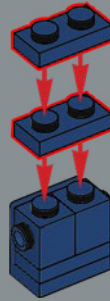

312

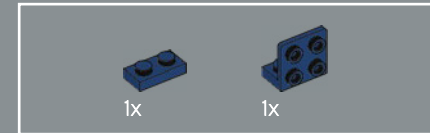
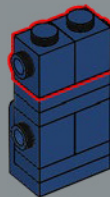

313

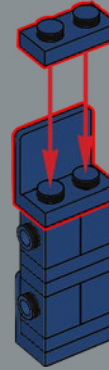

314

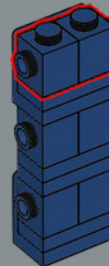

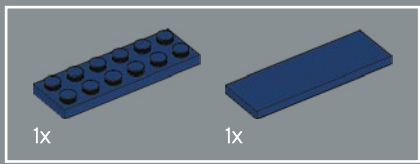

315

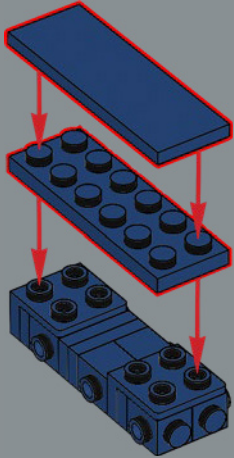

316

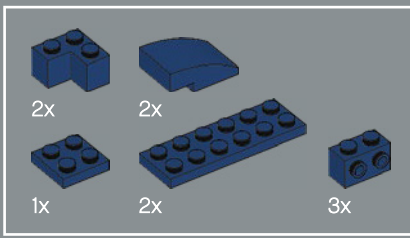
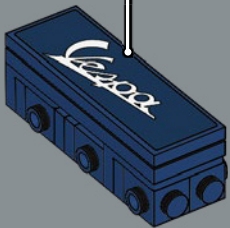

317

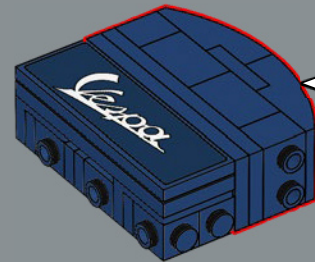
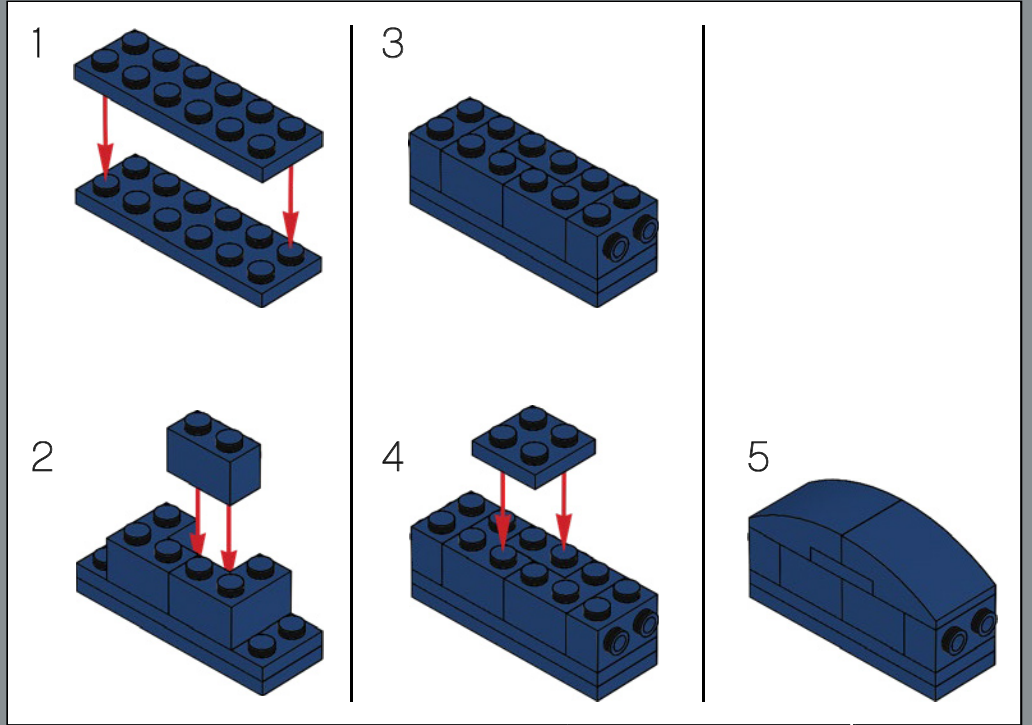

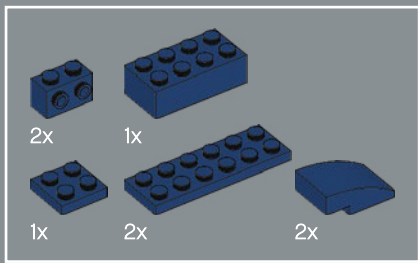

318

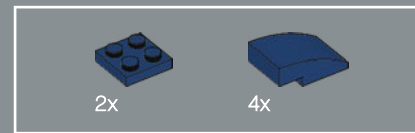
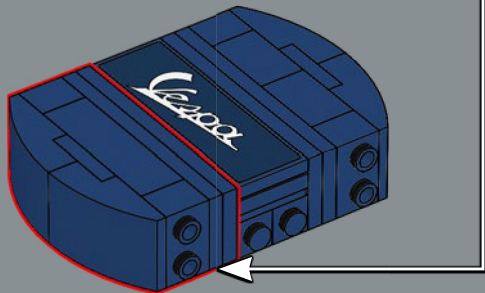
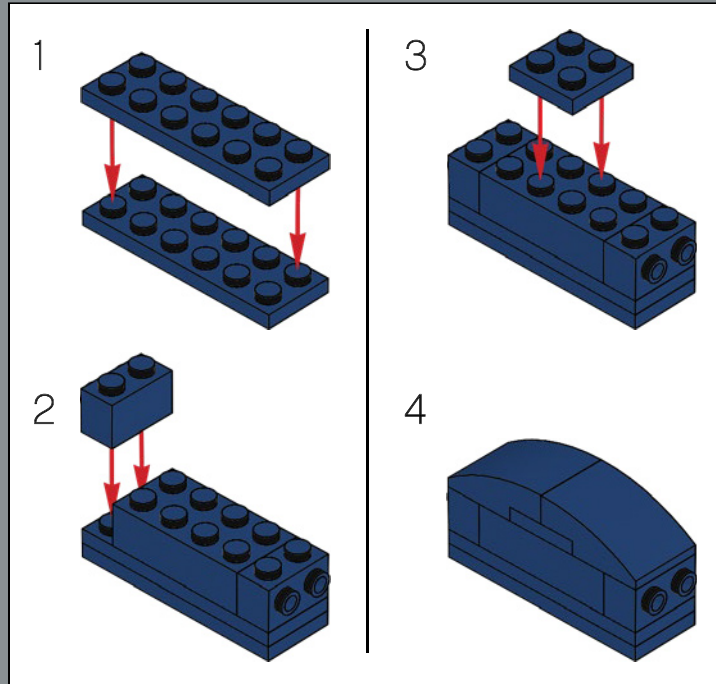

319

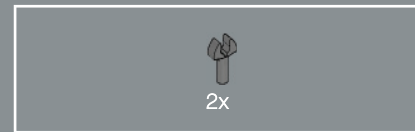
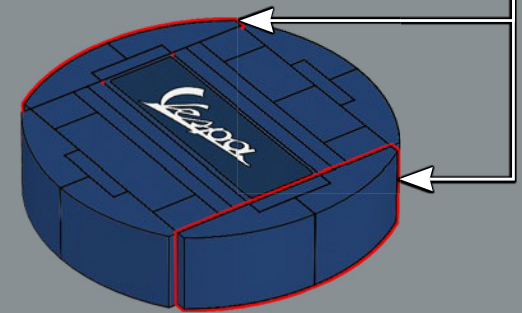
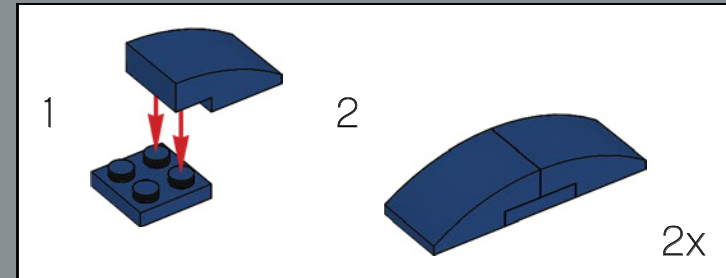

320

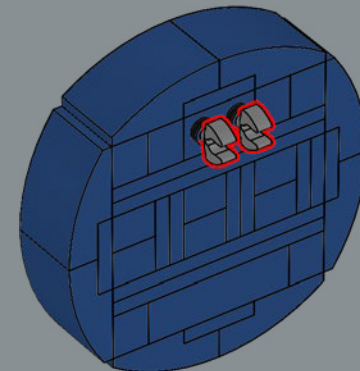

321

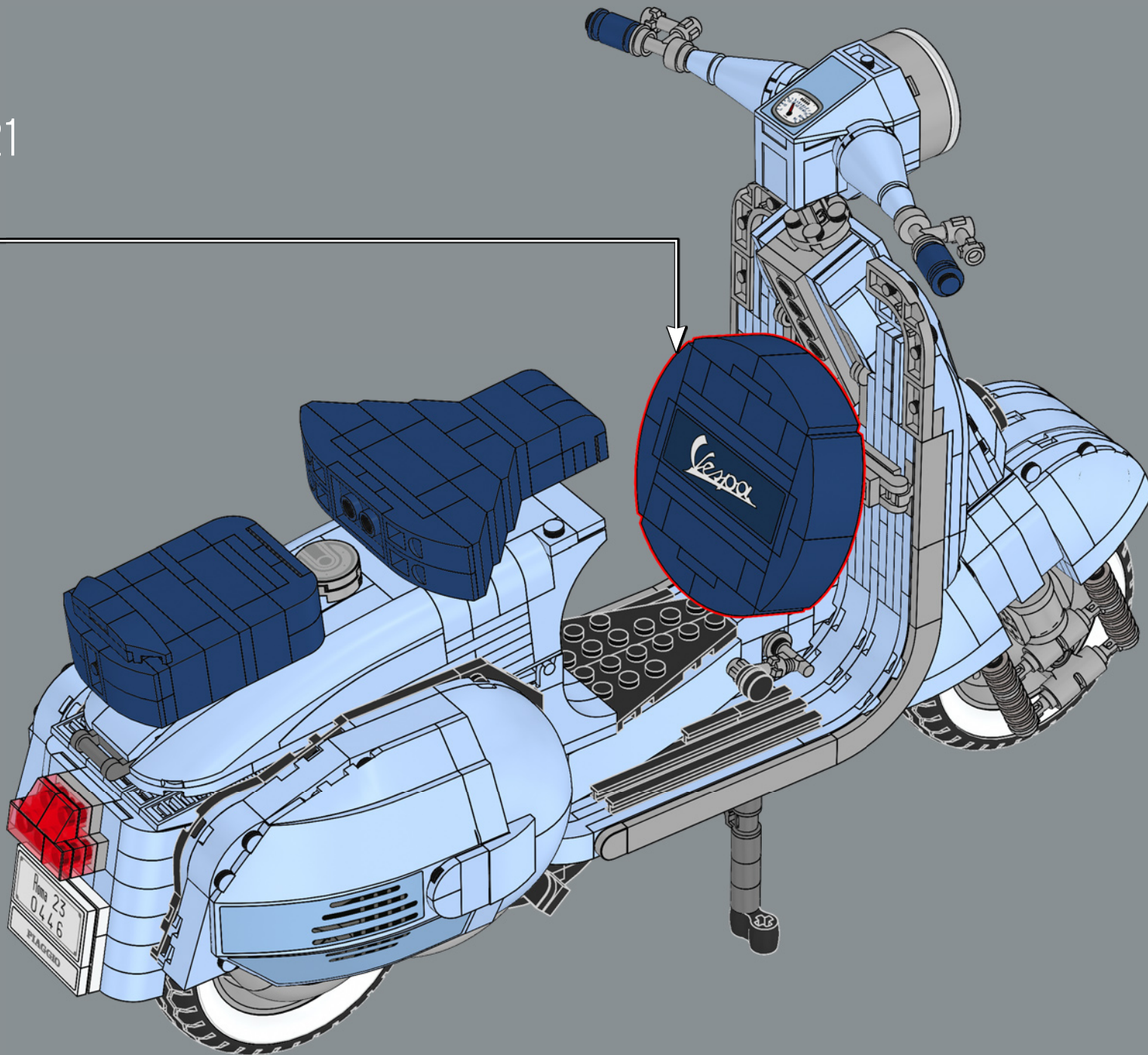

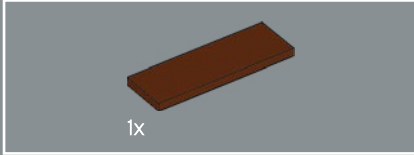
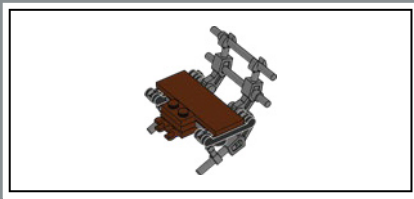

322

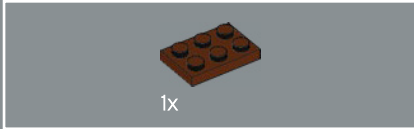

323

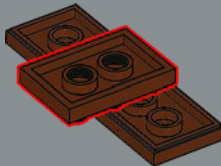

324

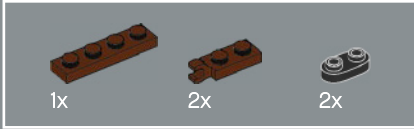
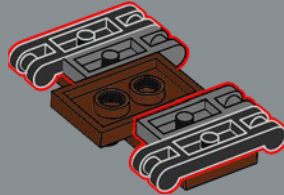

325

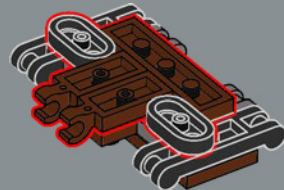

326

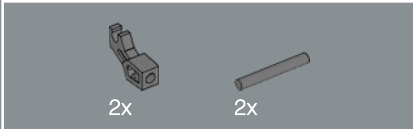
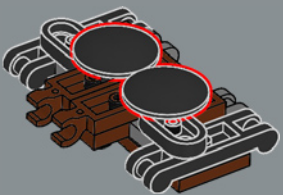

327

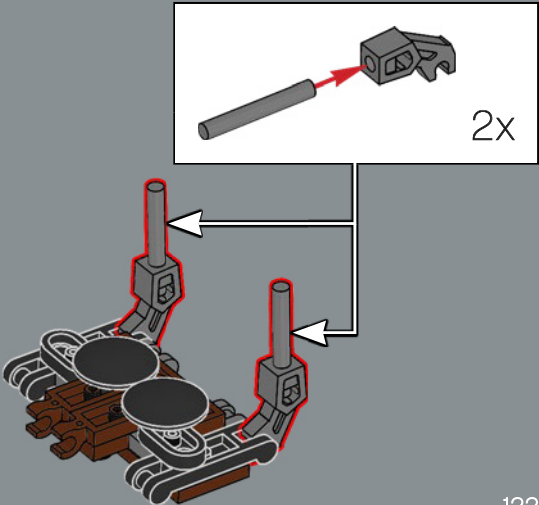



2x

328

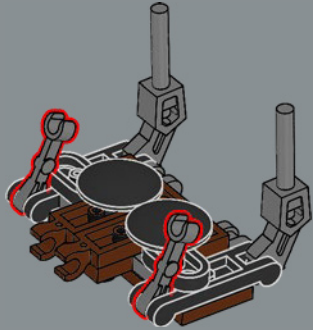

329

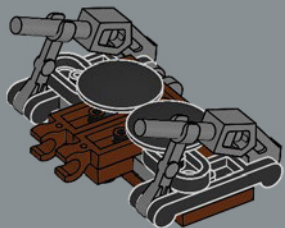

1x

330

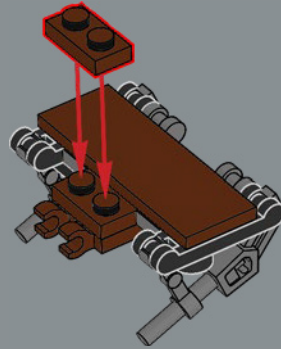

2x

331

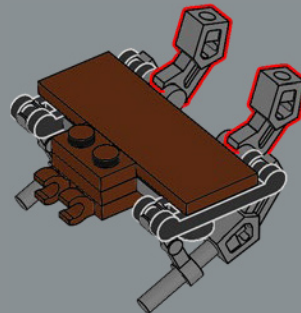

1x

332

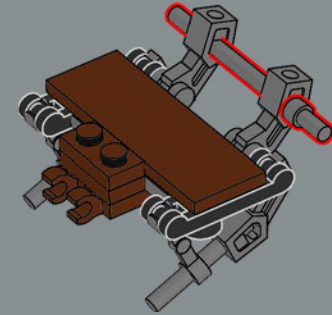

2x

333

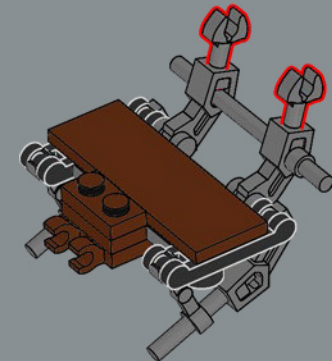

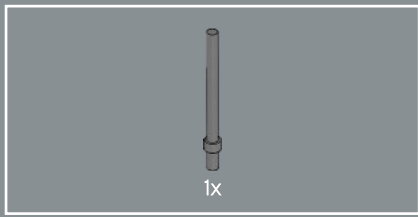

334

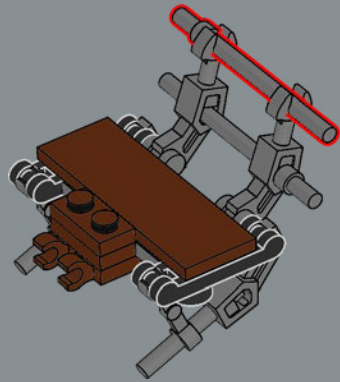

335

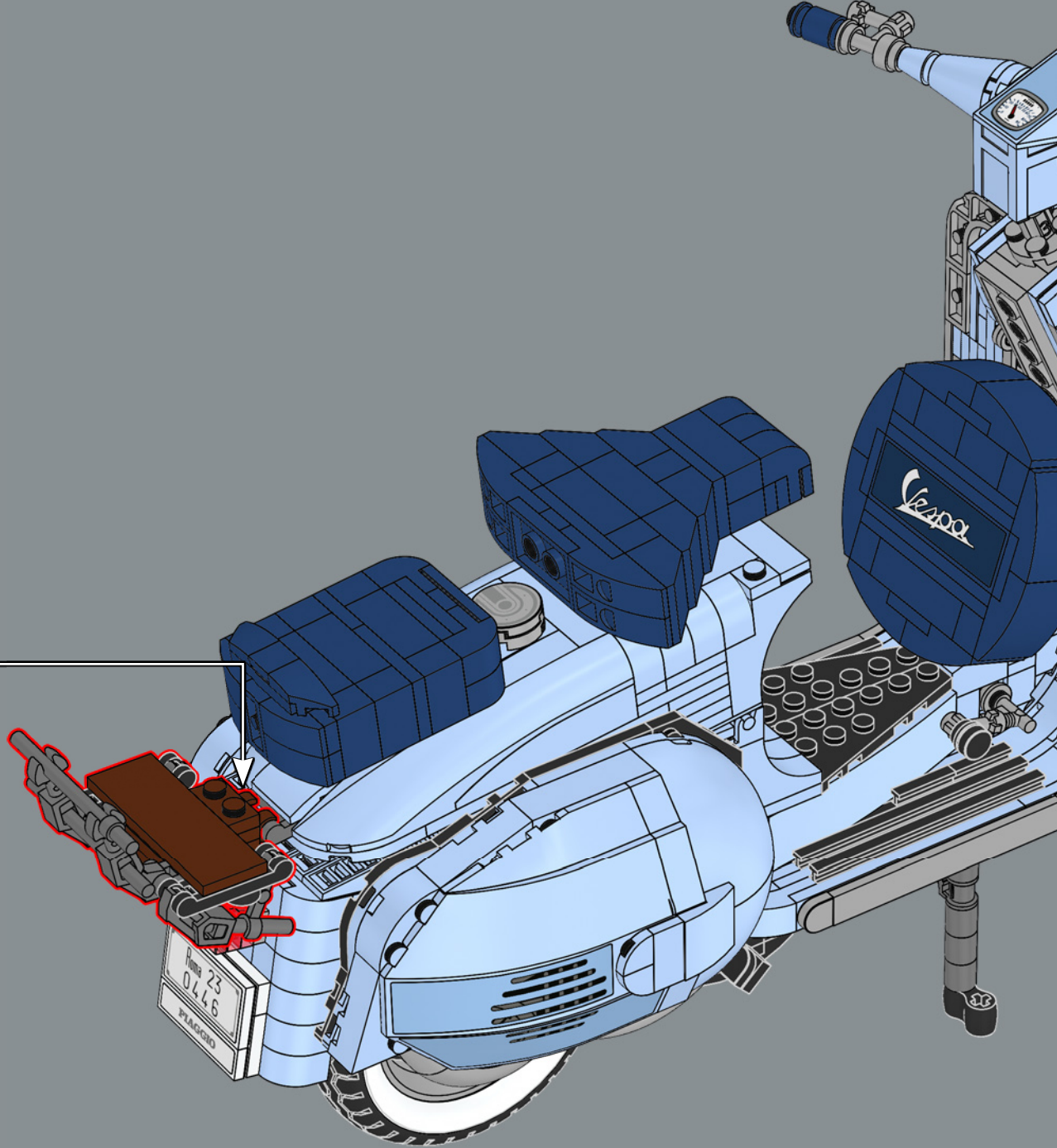

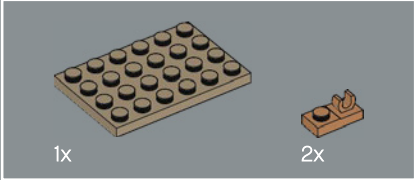
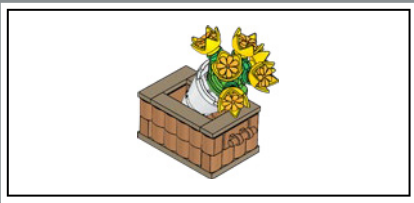

336

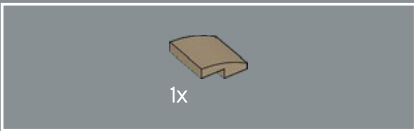
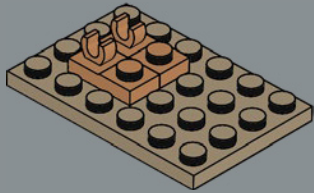

337

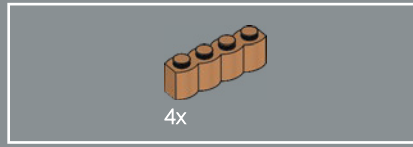
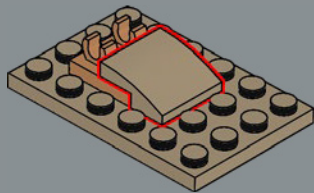

338

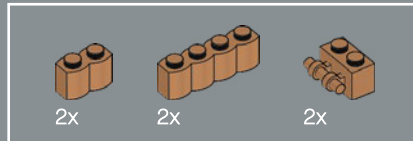
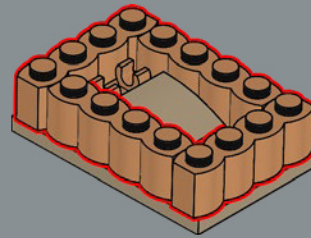

339

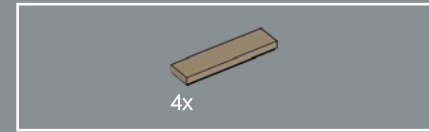
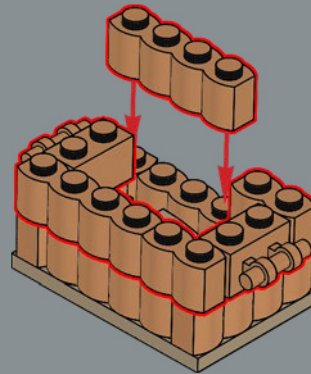

340

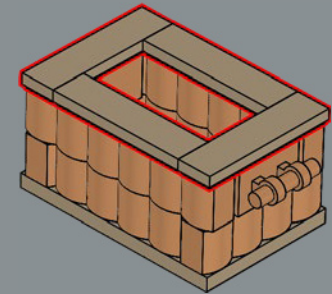

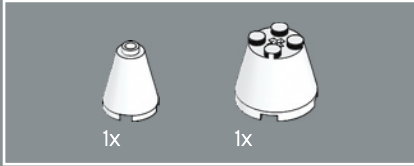
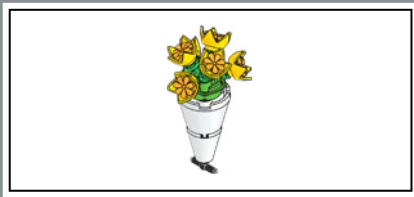

341

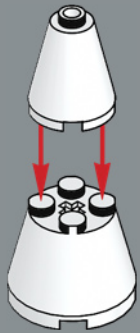

342

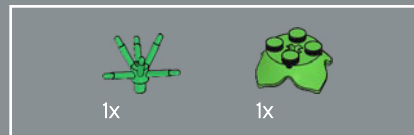
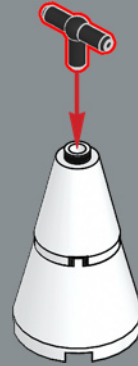

343

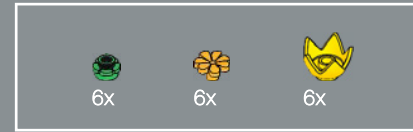
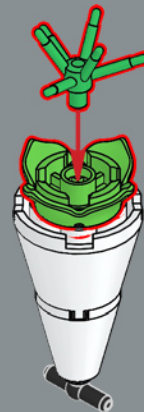

344

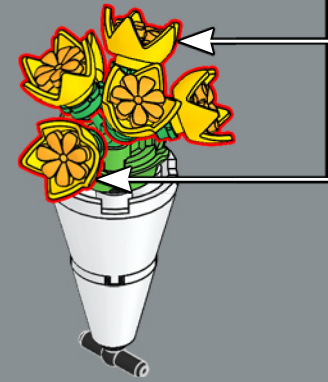
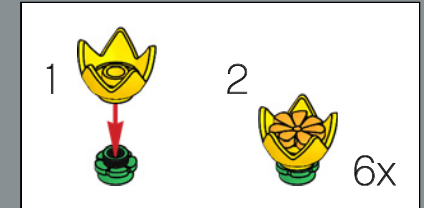

345

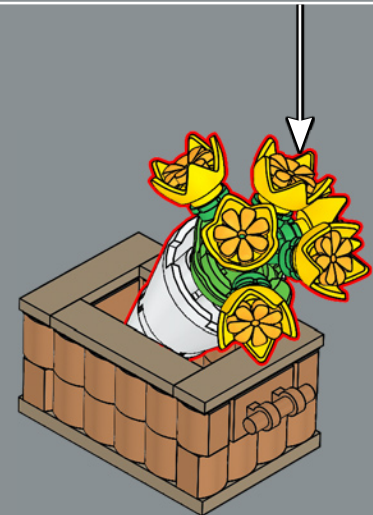

Thanks to popular culture, the Vespa has been elevated from a simple means of transportation to an Italian style icon appreciated worldwide.

Grâce à la culture populaire, la Vespa est passée du statut de simple moyen de transport à celui d'icône du style italien appréciée dans le monde entier.

La cultura popular ha elevado la Vespa de simple medio de transporte a ícono del estilo italiano apreciado en el mundo entero.

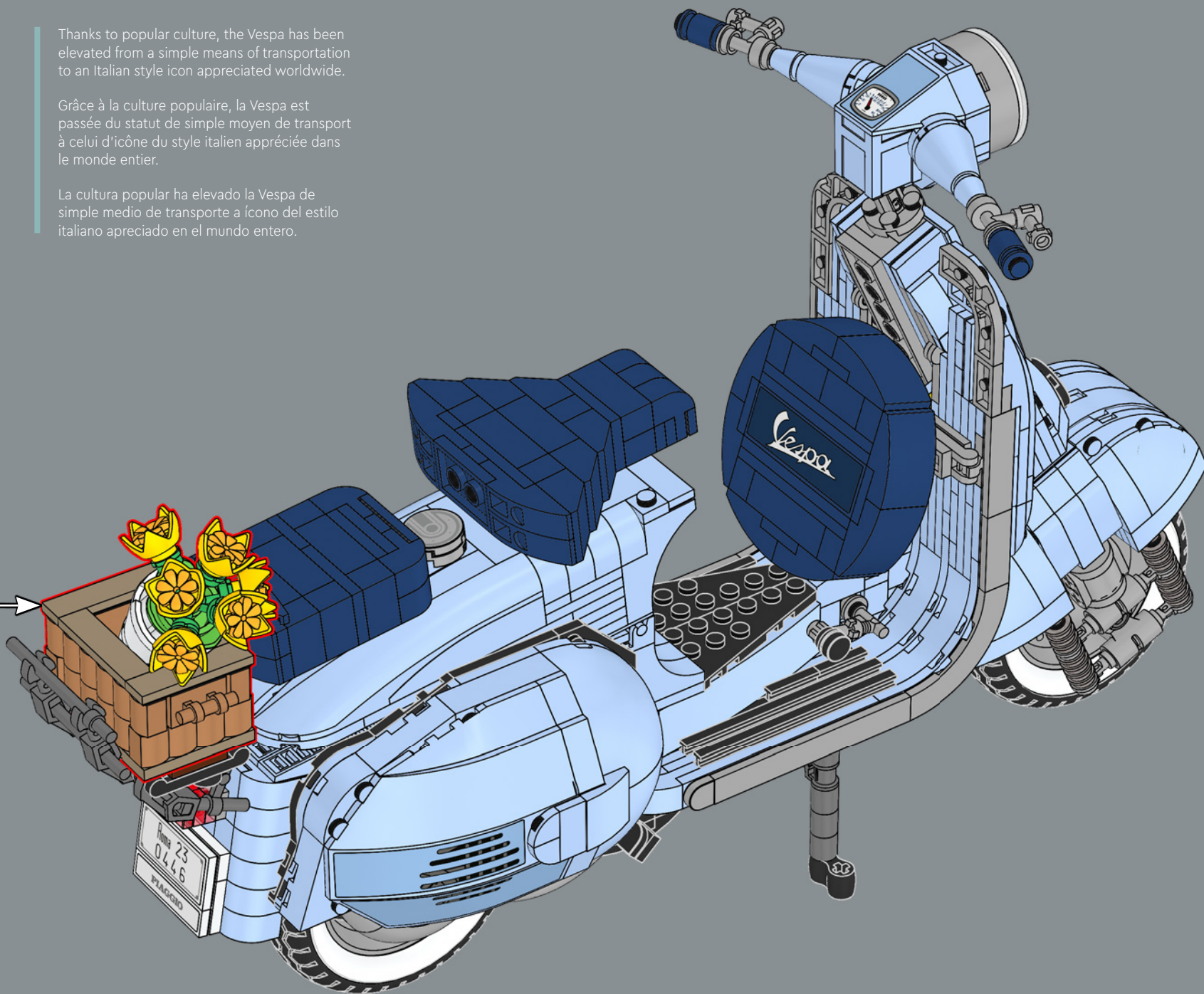

346

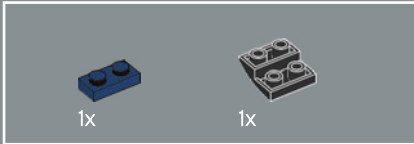
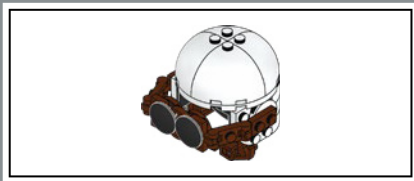

347

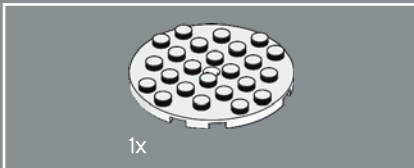
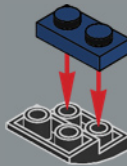

348

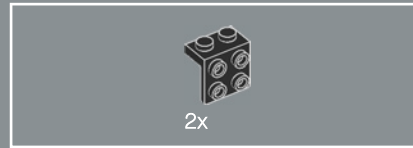
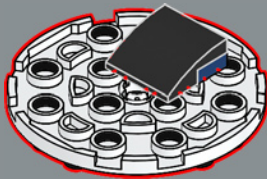

349

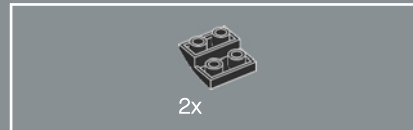
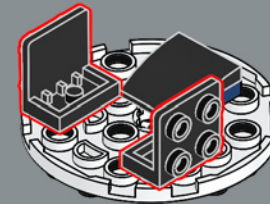

350

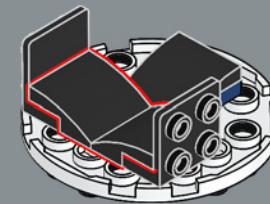

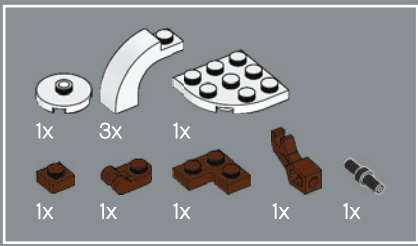

351

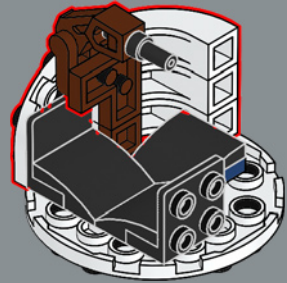
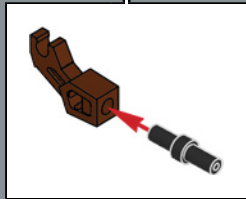
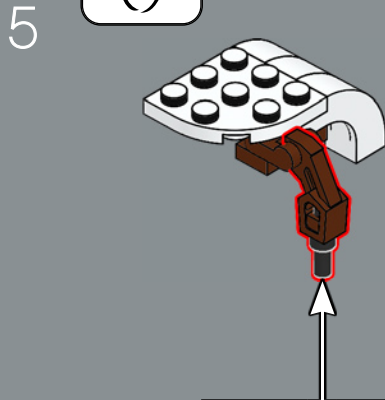
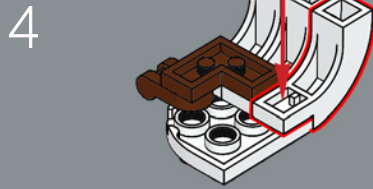
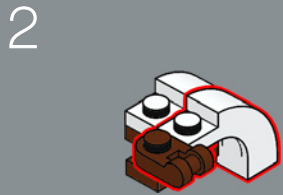
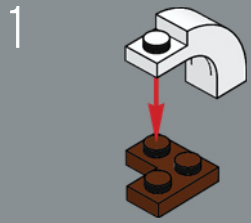

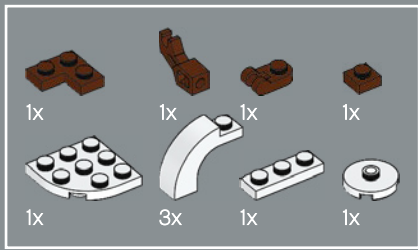

352

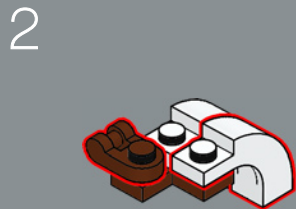
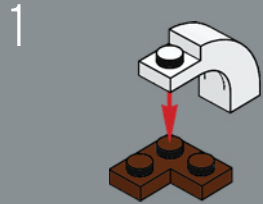

3



4

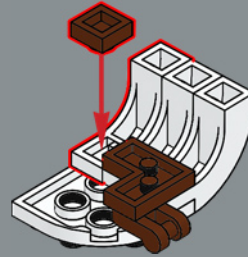

5

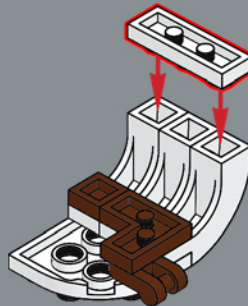

6

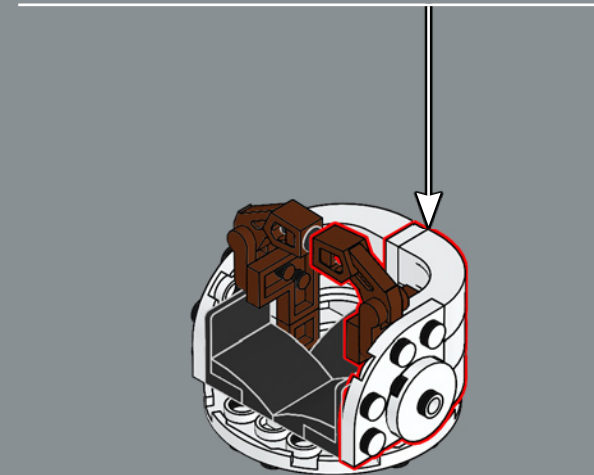
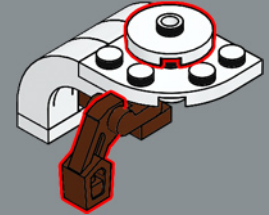



353

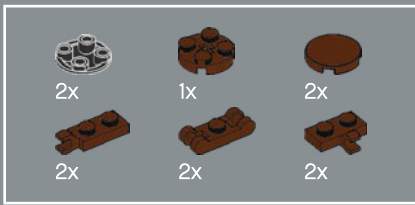

354

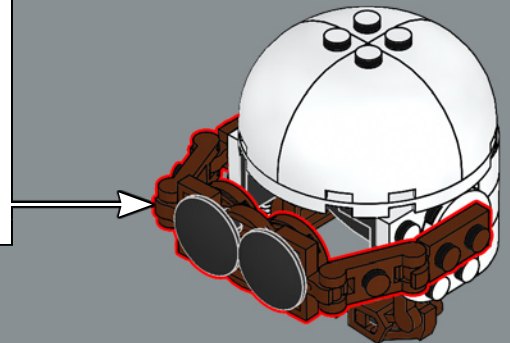
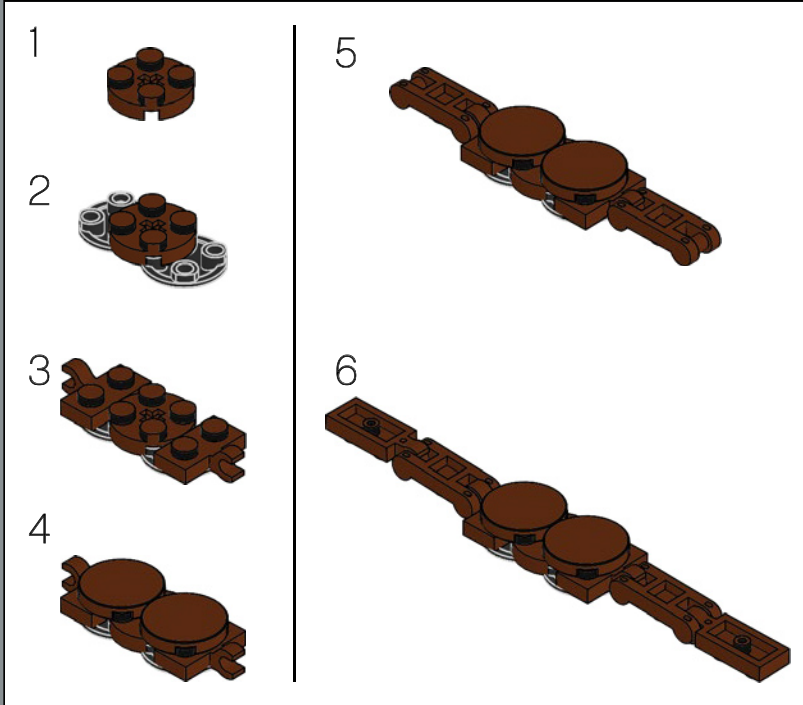
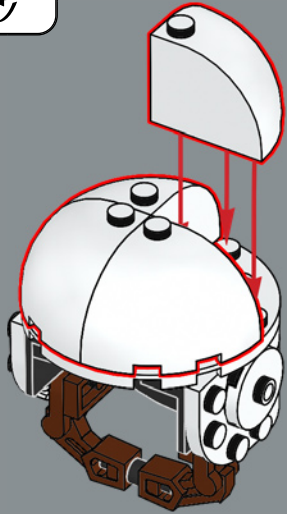

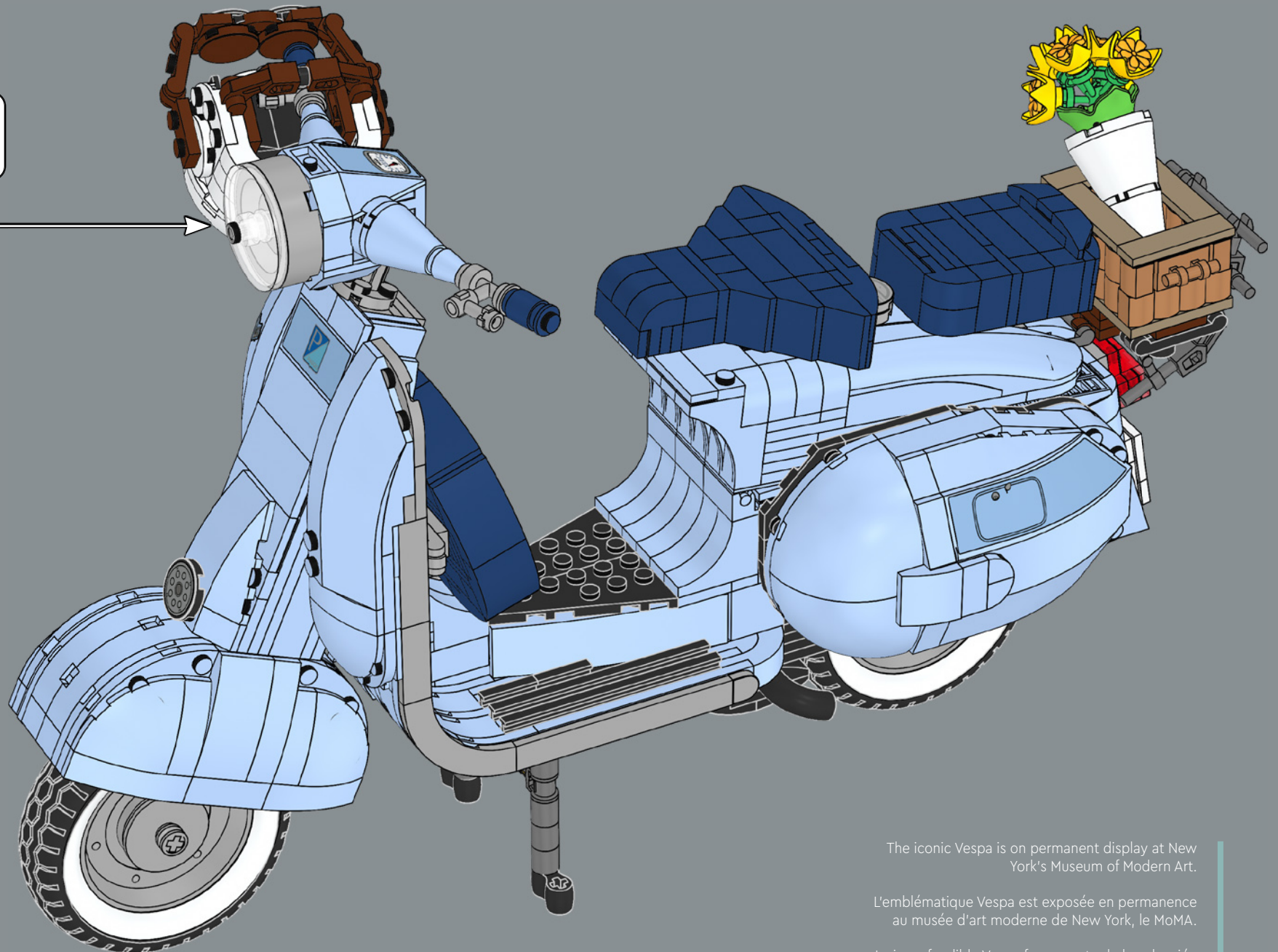

The iconic Vespa is on permanent display at New York's Museum of Modern Art.

L'emblématique Vespa est exposée en permanence au musée d'art moderne de New York, le MoMA.

La inconfundible Vespa forma parte de la colección permanente del MoMA de Nueva York.

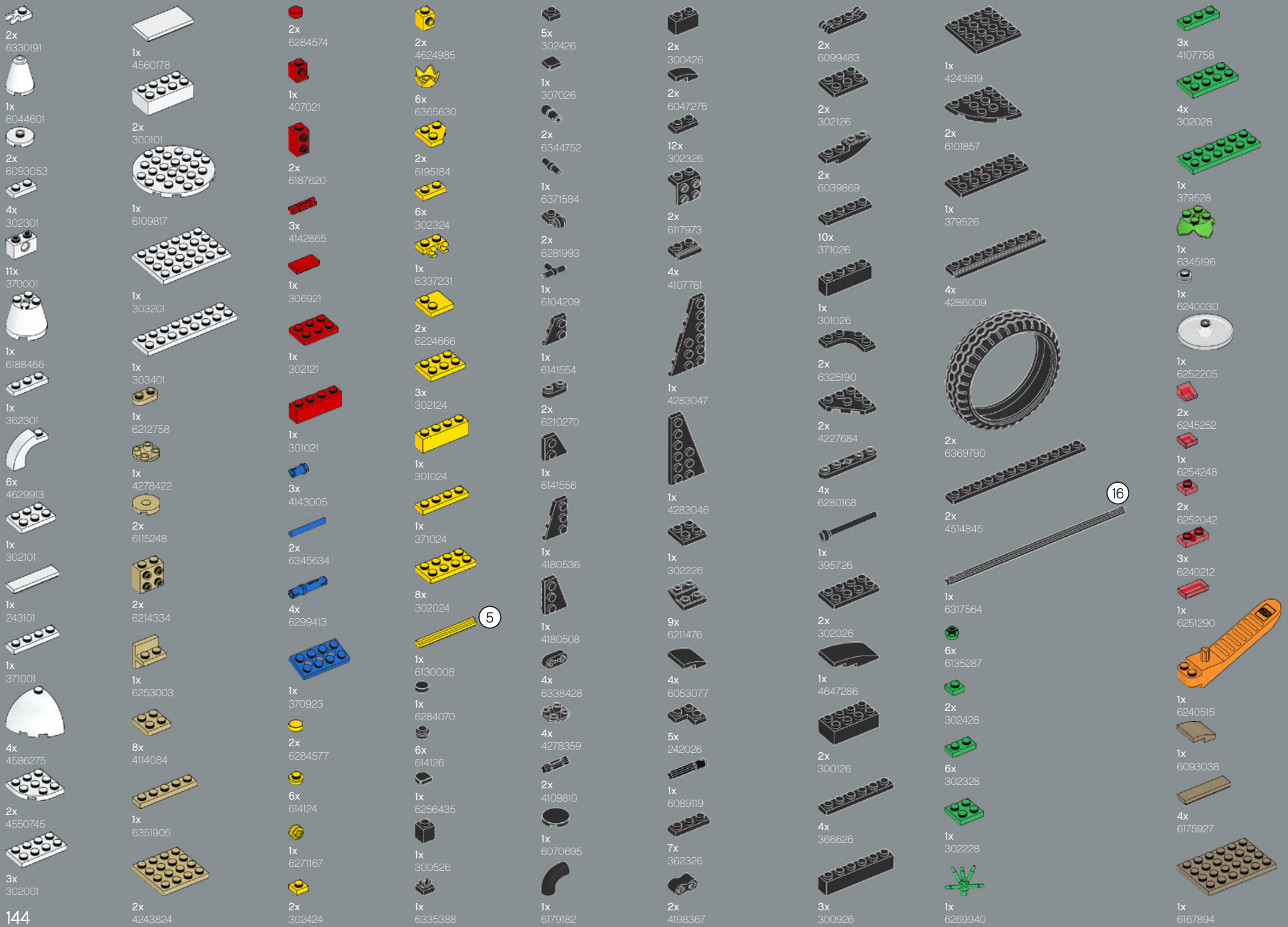

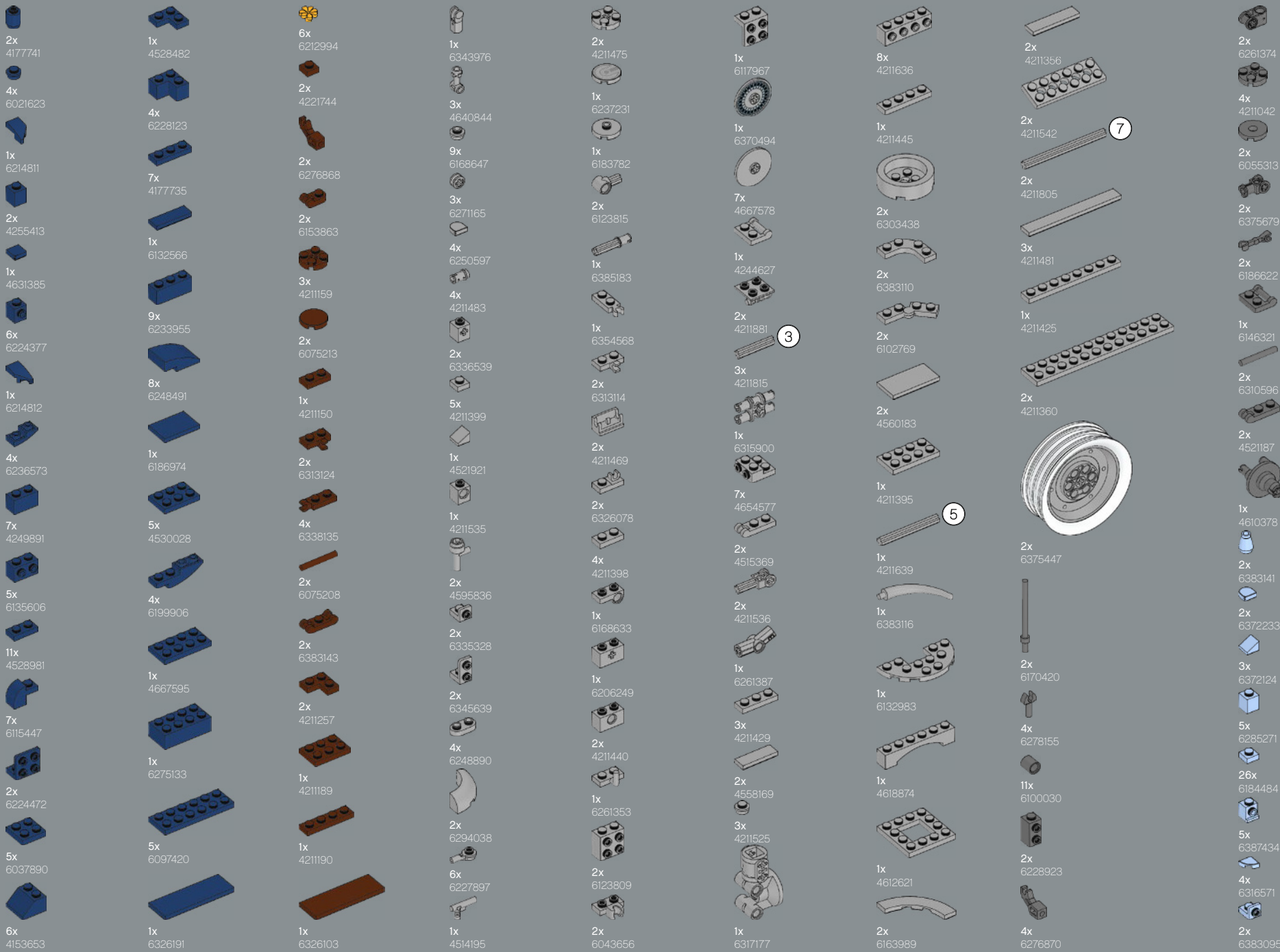



FEEDBACK AND WIN



FEEDBACK AND WIN

Your feedback will help shape the future development of this product series.

Please visit:

FEEDBACK UND GEWINNEN

Dein Feedback trägt zur Weiterentwicklung dieser Produktreihe bei.

Geh auf:

COMMENTEZ ET GAGNEZ

Vos commentaires nous aideront à concevoir les futurs produits de cette gamme.

Rendez-vous sur :

COMENTA Y GANA

Tu opinión nos ayudará a dar forma al desarrollo de esta serie de productos en el futuro.

Visita:

反馈有奖

您的反馈将有助于我们在今后改进本系列产品。

请访问：

[LEGO.com/productfeedback](https://www.lego.com/productfeedback)

By completing, you will automatically enter a drawing to win a LEGO® set.

Terms & Conditions apply.

Durch Ausfüllen nimmst du automatisch an der Verlosung eines LEGO® Preises teil.

Es gelten die Teilnahmebedingungen.

En envoyant vos commentaires, vous serez automatiquement inscrit(e) à un tirage au sort qui vous permettra de remporter un prix LEGO®.

Offre soumise à conditions.

Al contestar, participarás automáticamente en el sorteo y podrás ganar un set LEGO®.

Sujeto a Términos y Condiciones.

完成我们的反馈调查，即可自动进入抽奖环节，赢取乐高®套装。

适用《条款和条件》。

LEGO and the LEGO logo are trademarks of the/son des marques de commerce du/son marcas registradas de LEGO Group.
©2022 The LEGO Group.

VESPA® Official Product.
VESPA® is a registered trademark owned by Piaggio & C. S.p.A. and used under license by LEGO System A/S.

