

Honeywell

PX940 Series

High Performance Industrial Printer



User Guide

Disclaimer

Honeywell International Inc. (“HII”) reserves the right to make changes in specifications and other information contained in this document without prior notice, and the reader should in all cases consult HII to determine whether any such changes have been made. The information in this publication does not represent a commitment on the part of HII.

HII shall not be liable for technical or editorial errors or omissions contained herein; nor for incidental or consequential damages resulting from the furnishing, performance, or use of this material. HII disclaims all responsibility for the selection and use of software and/or hardware to achieve intended results.

This document contains proprietary information that is protected by copyright. All rights are reserved. No part of this document may be photocopied, reproduced, or translated into another language without the prior written consent of HII.

Copyright © 2019-2021 Honeywell International Inc. All rights reserved.

Web Address: sps.honeywell.com.

Trademarks

Microsoft® Windows®, Windows NT®, Windows 2000, Windows ME, Windows XP, and the Windows logo are trademarks or registered trademarks of Microsoft Corporation.

Wi-Fee is a registered certification mark of the Wi-Fee Alliance.

Bluetooth is a trademark of Bluetooth SIG, Inc., U.S.A.

Apple® and App Store® are registered trademarks of Apple Inc., registered in the U.S. and other countries.

Google™, Android™ and Google Play Store™ are registered trademarks of Google, LLC.

Zebra is a trademark or registered trademark of Zebra Corporation.

Other product names or marks mentioned in this document may be trademarks or registered trademarks of other companies and are the property of their respective owners.

For patent information, refer to www.hsmpats.com.

TABLE OF CONTENTS

Customer Support	xi
Technical Assistance	xi
Product Service and Repair	xi
Limited Warranty	xi
Safety Warnings	xii
Caution Statements	xii
Shipping the Printer	xii
Chapter 1 - Get Started	1
Features	1
About the Display.....	1
Back View (Ports and Power).....	2
Print Button.....	2
Ready Screen	2
Main Menu	3
Navigate the Main Menu	4
Wizards	4
Printing Wizard	5
Communications Wizard	5
Calibration Wizard.....	5
Printer Command Languages and Simulator Support Options	6
Autosense	6
Direct Protocol	6
Fingerprint.....	6
IPL.....	7

ZSim.....	7
DPL.....	7
Smart Printing.....	7
Access the Printer Web Page.....	7
Set the Printer Command Language.....	7
From the Printer Web Page.....	8
From the Main Menu.....	8

Chapter 2 - Set Up the Printer 9

Power Up the Printer.....	9
Calibrate the Touch Screen.....	10
To calibrate the screen from the website:.....	10
About the Media.....	10
Load Media for Tear-Off Printing.....	10
Load Media for Rewind Printing.....	14
Load Media for Peel-Off Printing.....	15
Load Fanfold Media.....	16
About the Ribbon.....	17
Load Ribbon.....	17
Ribbon Removal.....	18
Print a Test Label.....	19
Printhead Pressure and Toggle Position.....	19
Pressure Adjustment.....	19
Toggle Position Adjustment.....	20
Toggle Settings.....	20

Chapter 3 - Connect the Printer 21

Connect the Printer to Your PC.....	21
Connect the Printer Using a Serial Cable.....	21
Connect the Printer Using a USB Cable.....	21
Connect the Printer to Your Network.....	21
Connect the Printer to an Ethernet Network.....	22
Configure Bluetooth Communications from the Web Page.....	22

Configure Bluetooth Communications from the Main Menu	23
Connect the Printer via Wi-Fi.....	23
Configure Wi-Fi Communications from the Web Page	23
Configure Wi-Fi Communications from the Main Menu	24
Install Authentication Certificates	24
Printer Drivers.....	24
Install Honeywell Windows Driver	25
USB Host Port.....	25
Connect a USB Device	25

Chapter 4 - Configure the Printer27

Printer Configuration Menus	27
Printer Configuration.....	28
Restrict Access to the Main Menu	28
Access the Printer Web Page	28
Printer Webpage User Name and Password.....	29
Configure the Printer from the Web Page.....	29
Configure the Printer with PrintSet 5 or Print Set MC.....	30
Configure the Printer with Programming Commands.....	30
Uploading from the Web Page	30
Uploading from a USB Storage Device	31
Change Background Image for the Ready Screen.....	31
Printer Profiles.....	32
Save a Printer Profile from the Web Page.....	32
Load a Printer Profile from the Web Page	32
Save a Printer Profile from the Main Menu.....	33
Load a Printer Profile from the Main Menu	33
Load a Printer Profile Using Programming Commands.....	33
Install a Configuration File from a USB Storage Device	34
Export a Configuration File to a USB Storage Device.....	34
Menu Shortcuts	35
Create Menu Shortcuts	35
Customize the Printer Web Page	36

Chapter 5 - About the Verifier..... 37

- Setting up the Verifier 37
 - Webpage 37
 - Front Panel..... 37
- Calibration 38
 - Verifier Calibration Card 38
 - Handling Instructions..... 38
 - Calibrating the Verifier 39
 - About Expired Verifier Calibration 39
- Verification Settings 40
 - Verification Type 40
 - Grading Override 40
 - Report Level..... 41
 - Passing Grade..... 41
 - Aperture 41
 - Maximum Consecutive Failures..... 41
 - Verification Failure Action 41
 - About Reprint Mode 42
 - Save Label Images..... 42
 - Void Pattern 42
 - Supported Command Language and Speed 42
 - Barcode Symbolologies Supported 43
 - Supported Barcodes and Commands..... 44
 - Barcode Orientations..... 45
 - Barcode Size Supported 45
 - Verification Length 45
 - Maximum Number of Barcodes per Label..... 46
 - Printing Behavior after Error Recovery..... 46
 - Printing Behavior after Recovered from error above: 46
 - Unsupported Barcode Behavior..... 48
 - Example:..... 48
 - Verify Unsupported Barcode..... 48
 - Selective Barcode Verification 48
 - Verification Failed Error Handling..... 49

Failed Label Image File	50
USB Thumbdrive	50
Reporting and Statistics	50
Report Formats.....	51
Individual Report	51
Report Header	52
Barcode Information	53
Failure Reason Information.....	54
Barcode Grading Parameters	54
All Supported 1D Barcodes Overall Parameters	55
2D Barcode, DataMatrix Overall Parameters	56
2D Barcode, QR Barcode Overall Parameters	57
1D barcode 10 line Profile Grading Parameters	59
Restore Default Verification Files.....	60
Fingerprint Command.....	60
About Barcode Template.....	61
Graphic Barcode	61
Parameters	64
Fingerprint Application Support	66
About Data Reporting.....	67
Verification Report Level	67
Verification Report Format	67
Web Page Reporting.....	68
About FTP/SFTP Push.....	69
About USB Reporting	70
About Save Label Images	71
About LCD Reporting.....	72
.....	72
LCD Reporting-Barcode Result	72
Chapter 6 - Troubleshooting.....	73
System Information.....	73
Statistics.....	73
Printer Odometer	74

Maintenance Alerts.....	74
Set Alerts.....	74
Alert Notifications	75
Error Alerts and Solutions.....	75
Verifier Error Alerts and Solutions.....	76
Troubleshoot Printer Problems and Find Solutions	77
Print Problems.....	77
Verifier Problems	78
Networking Problems.....	79
Restore Printer Defaults.....	79
Restore Defaults from the Printer Web Page	80
Restore Defaults from the Main Menu	80
Restore Defaults with a Hardware-Based Reset.....	81
Upgrade the Printer Firmware.....	81
Upgrade Firmware from the Printer Web Page	81
Upgrade Firmware from a USB Storage Device	81

Chapter 7 - Maintenance 83

Clean the Printer	83
Clean the Printhead	84
Clean the Front Sensor (PX940A).....	85
Clean the Verifier (PX940V).....	85
Clean the Media Path	85
Clean the Exterior of the Printer.....	86
Replace the Printhead	86
Replace the Platen Roller	87
Label Taken Sensor Calibration.....	88
Label Gap and Black Mark Sensor Adjustments	88

Chapter 8 - Product Specifications..... 89

Printer and Environmental Specifications	89
Command Languages and Simulator Support Features	89
Print Sensors	89

Network Services	90
Fonts.....	90
Resident Fonts	90
Downloadable Fonts.....	91
Supported Font Types.....	91
Printed Barcode Symbologies	91
1D Barcode Symbologies.....	91
2D Barcode Symbologies.....	92
Graphic File Types	92

Appendix A - Default Settings95

Communications Settings.....	95
Serial Port	95
Ethernet.....	96
Bluetooth Settings.....	96
Media Settings	96
Print Quality Settings	99
About Label Rotation.....	99
Rotation Point and Rotation Radius	99
Rotation Scenarios.....	100
Media Margin (X) (dots) and Label Top Adjust (dots).....	102
System Settings.....	102
General System	102
Display and Audio Settings	103
System I/O.....	104
System Network Services	105
Verification Settings.....	106
Error Handling Settings	106
Network Exporting Settings.....	107
Data Exporting Settings	108
Barcode Settings	108
Verifier Integration Interface (VII) Settings	109
Maintenance Alerts	109

Appendix B - Print Labels with INPrint111
 The INPrint Page 111
 Print INPrint Labels 111

Appendix C - Accessories and Options.....113
 Printer Accessories and Options 113

Customer Support

Technical Assistance

To search our knowledge base for a solution or to log in to the Technical Support portal and report a problem, go to sps.honeywell.com.

For our latest contact information, go to sps.honeywell.com.

Product Service and Repair

Honeywell International Inc. provides service for all of its products through service centers throughout the world. Go to sps.honeywell.com and select Support to find a service center near you or to get a Return Material Authorization number (RMA #) before returning a product.

Limited Warranty

For warranty information, go to sps.honeywell.com and click **Support > Warranties**.

Safety Warnings



Warning: Do not put your fingers inside the print mechanism when the power is on.



Warning: This printer contains a coin battery and is NOT user replaceable. Keep children away from the printer when the printer is in service.

Never put batteries in your mouth as swallowing may lead to serious injury or death. If swallowed, seek medical attention immediately from a physician or local poison control center.

Caution Statements



Caution: Observe all safety and accident prevention regulations applicable to your specific region and application.



Caution: You must implement both hardware and software safety precautions to prevent the possibility of undefined system states.



Caution: You must make sure that dangerous conditions cannot occur under any circumstances, even for a brief period of time.



Caution: To reduce the risk of electric shock or fire, keep the cover closed and turn off the printer when not in use. There are no user-serviceable parts inside the power supply unit.

Shipping the Printer

To avoid printer damage during transit:

1. Power off the printer and remove all cables.
2. Remove media and ribbon (if installed) from the printer.
3. Lower the printhead and front arm.
4. Pack the printer in the original container.

Note: Honeywell is not responsible for any damage caused during shipment/transit.

GET STARTED

The PX940 industrial printer series includes:

- PX940 Productivity version (PX940A)
- PX940 Verifier version (PX940V) with an integrated barcode verification module.

Both PX940A and PX940V printers are rugged label printers that include integrated USB, RS-232, Ethernet, and Bluetooth LE interfaces. You can connect the printers to a single PC, a wired network, or a wireless (optional) network.

Note: *Bluetooth LE is only used with Print Set MC to configure the printer on Android and iOS devices.*



Caution: Read and review the warnings in this manual carefully before connecting the printer.

Features

- USB host port for connecting storage devices, scanners, or keyboards.
- USB device port to connect to a PC.
- Support for printer command languages including Fingerprint (FP), Direct Protocol (DP), Intermec Printer Language (IPL), Zebra Simulation (ZSim), Datamax Printer Language (DPL), and Smart Printing.

About the Display

The front panel has a 3.5 inch full-touch screen that supports touch input with fingers, gloved hands, or a stylus.

Back View (Ports and Power)

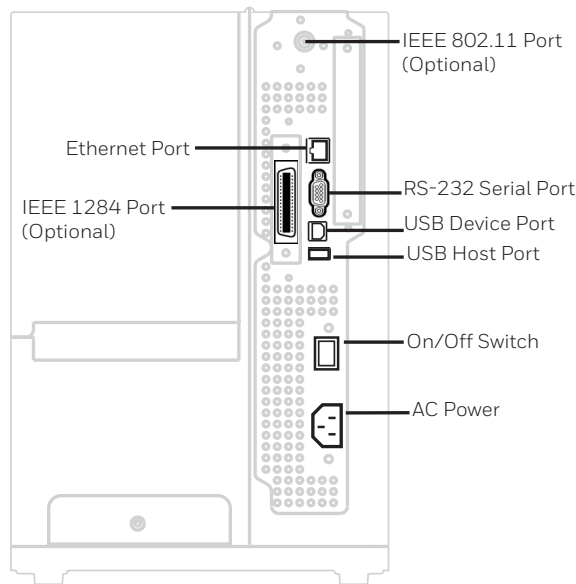

Print Button

Use the **Print** button to feed media, pause print jobs, calibrate, test feed, and print.



Printer State	Print Button Action
Startup	Press the Print button during startup to enter Calibration mode or to restore defaults if the printhead is lifted.
Ready	Press the Print button to advance the media.
	If the print key feature is on, press the Print button to reprint the last job.
	Press and hold the Print button to calibrate the media sensors.
Printing	Press the Print button to stop or pause printing. The printer stops after completing the current label.
Paused	Press the Print button to resume printing.
Error	Press the Print button to advance the media.





Ready Screen

The Ready Screen appears when the printer is powered on and has completed its startup process.

Note: The icon for Wi-Fi status appears only when the optional Wi-Fi module is installed.

By default, the information bar at the bottom of the screen shows the printer command language and the printer IP address. You will see the time and current date only if the real time clock (RTC) is installed. You can customize the screen to show different types of information.

The status bar at the top of the screen includes these icons:

Icon	Name	Description
	Main Menu	Press the icon to view the main menu for your printer.
	Communications	Press the icon to view communications information for your printer.
	Printing	Press the icon to view specific printer information.
	Bluetooth	Press the icon to view Bluetooth LE information for your printer.
	Back	Press this icon to navigate back through the printer menus.

Main Menu

On the printer Ready screen, press  to view the Main Menu.

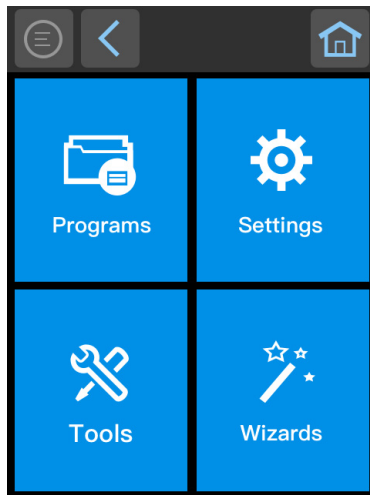

Note: If you create menu shortcuts, the Main Menu is replaced by the Quick Choices menu.

Press a button to select the **Programs**, **Settings**, **Tools**, or **Wizards** menu.









- **Programs** displays a list of programs installed on the printer. This list includes utility programs provided as part of the firmware and programs you have installed. **Programs** appears in the Main Menu only if the printer is using Fingerprint or Direct Protocol as the command language.

- Select **Settings** to view and change printer settings.
- Select **Tools** to print test labels, manage a connected USB storage device, restore printer default settings, or save and load printer profiles.
- Select **Wizards** to see a list of wizards that help you configure printing or communication settings, or calibrate the media sensors.

Note: *The printer cannot print while the Main Menu is showing. Exit the Main Menu and return to the Ready screen to begin printing.*

Navigate the Main Menu

Use the status bar buttons to navigate between menus in the Main menu and save changes.

Button	Description
	Returns to the Main menu
	Goes back one level in the menu
	Returns to the Ready screen
	Moves between options in a settings menu
	Moves to additional options not viewable in the menu
	Bluetooth: Gives the device name and device address
	Information: Gives Communications information such as Ethernet, Serial, and USB.
	Printer Information

Note: *Use the horizontal scroll bar for settings with additional options.*

Wizards

The printer includes several wizards you can use to quickly set up your printer. You can start all of the wizards from the Main menu except for the startup wizard. The startup wizard appears the first time you turn on the printer and after the printer has been reset to the factory default state.

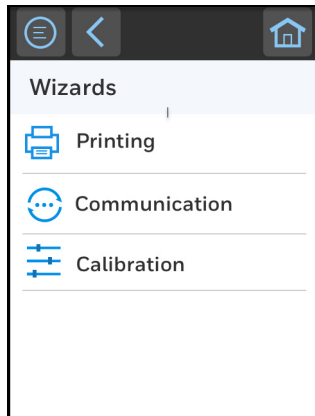

Printing Wizard

Wizard	Description
Media Loading Guide	Shows how to load media.
Ribbon Loading Guide	Shows how to load ribbon.
Media Setup	Select media and printing type (DT or TTR), media width, length, and X-margin, Label Reset and Label Top Adjust values, and print speed.
Print Quality	Prints a series of labels to determine the best print quality setting.

Communications Wizard

Wizard	Description
Line Analyzer	Logs all incoming data on all communications channels and saves the data to a log file. For advanced users.

Calibration Wizard

Wizard	Description
Media	Calibrates all media sensors and shows current print settings.
Verifier	Calibrates the Verifier. (for PX940V only)
Label Taken Sensor	Calibrates the label taken sensor used with the label dispenser. Available when the label taken sensor is installed.
Date and Time	Calibrates the date and time.
Screen	Calibrates the touch screen.

Printer Command Languages and Simulator Support Options

A printer command language is a set of instructions that controls printer functions:

- Configure the printer.
- Return the status of the printer.
- Control peripheral devices.
- Format a label or receipt for printing.

The printer supports these command languages and language simulator support options:

- [Autosense](#)
- [Direct Protocol](#)
- [Fingerprint](#)
- [IPL](#)
- [ZSim](#)
- [DPL](#)
- [Smart Printing](#)

Autosense

Autosense allows the printer to automatically sense from label to label, the incoming data stream and its language, and print each label accordingly.

Note: *Autosense is the default printer configuration and does not support an IPL data stream.*

Direct Protocol

Direct Protocol (DP) uses a more intuitive English-like syntax. Direct Protocol lets you combine predefined layouts and variable data to create labels, tickets, and tags. If you are using barcode software, select Direct Protocol as your printer command language.

Fingerprint

Fingerprint is a BASIC-inspired general purpose printer language. Use Fingerprint to design custom label formats and write printer application software. If you plan to run Smart Printing applications directly on the printer, without connecting to a PC, select Fingerprint as your printer command language.

IPL

IPL is a host-based printer command language. Use IPL to design, modify, and download label formats, write printer application software, and configure the printer. If you are sending IPL label files to the printer, select IPL as your printer command language.

Note: *IPL can be supported on 200dpi and 300dpi printers only.*

ZSim

The ZSim (Zebra Printer Language Simulator) interprets Zebra™ programs (ZPL II or later) without requiring any host programming changes. If you are sending ZPL label files to the printer, select ZSim as your printer command language.

DPL

The DPL command language interprets Datamax™ data streams without requiring any host programming changes. If you are sending DPL label files to the printer, select DPL as your printer command language.

Smart Printing

Smart Printing refers to the ability of the printer to independently run printing operations without being connected to a host computer. If you are running printer-based applications written in C#, select Smart Printing as your printer command language.

Access the Printer Web Page

1. Open a browser window on your PC.
2. In the location or address bar, type the printer IP address and press **Enter**.
3. Click **Login**. The Login page appears.

You will be prompted for a user name and password. The defaults are:

- User Name: **itadmin**
- Password: **pass**

After logging in, you will be prompted to change your password.

Set the Printer Command Language

You can use one of these methods to change the printer command language:

- From the printer web page
- From the Main Menu
- PrintSet 5
- Print Set MC

From the Printer Web Page

To set the command language from the printer web page, you need to turn on the printer and connect to your network.

1. Make sure that the printer has media and ribbon installed (if necessary).
2. Follow the directions to [Access the Printer Web Page](#).
3. Once you are logged in to the printer web page, click the **Configure** tab.
4. Click **System Settings > General**.
5. select the printer command language you want to used from the Command Language list, and then click **Save**. A restart button will appear at the top of the page.
6. Click **Restart**.

From the Main Menu

You can use this procedure to change the printer command language from the main menu on the printer.

1. From the Ready screen, press the **Main Menu** button.
2. From the Main Menu, press **Settings > System Settings > General**.
3. Scroll down until you reach **Command Language**, and make your selection.
4. **Restart** the printer: the printer starts up in the command language that you selected.

SET UP THE PRINTER

This section contains information about loading media and ribbon, printing a test label, calibrating the screen, and adjusting the printer.

Power Up the Printer

The printer goes through a startup wizard the first time you turn on the power.

1. Connect one end of the power cord to the back of the printer and plug the other end to AC power.



Warning: Installing the printer requires a power cord connected to a socket-outlet with an earthing connection.

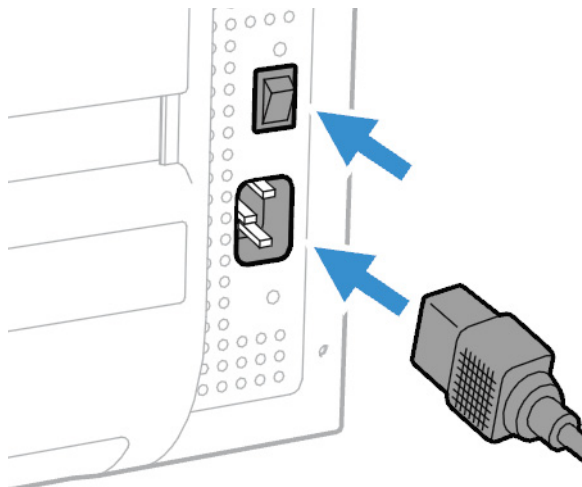

2. Press the power switch to turn on the printer.
3. As the printer starts up, a progress bar appears, then the startup wizard appears.
4. Follow the steps on the touch screen to complete the startup wizard.

Calibrate the Touch Screen

You can calibrate the screen from the printer website or from the touch panel on the printer.

To calibrate the screen from the website:

To access the website, make sure your printer is connected to the same network as your computer.

1. Open your browser and type the printer IP address into the web address bar.
2. In the menu section, click on **Services > Screen Calibration**. If you are prompted to login, the temporary username is **itadmin** and the password is **pass**.
3. Click on the blue **Screen Calibration** button, this will engage the touch panel to start screen calibration.
 - When the small square appears on the front touch panel of the printer, **touch the square** and continue to touch the square until the printer beeps.
4. Once calibration is complete, your touch screen will automatically return to the **Ready** screen.

Note: *Typical screen calibration consists of five touches (one in each corner and one in the middle of the screen)*

About the Media

The printers can print on labels, tickets, tags, and continuous stock. The procedure you use to load media depends on how you are operating the printer and the options you have installed.

Note: *The PX940 series printers only support out-wound media.*

Load Media for Tear-Off Printing

Tear-off printing is applicable to media with perforation. Printed labels, tickets, and other printed media are manually torn from the front of the printer. These of media can be used for tear-off printing:

- Non-adhesive continuous stock.
- Self-adhesive continuous stock with liner.
- Self-adhesive labels with liner.
- Tickets with gaps, with or without perforations.
- Tickets with black marks, with or without perforations.

To load media for tear off printing:

1. Open the media cover and remove the rewinder plate (if installed).



Warning: Moving parts are exposed when the cover is open. Make sure the cover is closed before operating the printer.



Warning: The tear bar contains sharp edges. Keep fingers and other body parts away from the tear bar.

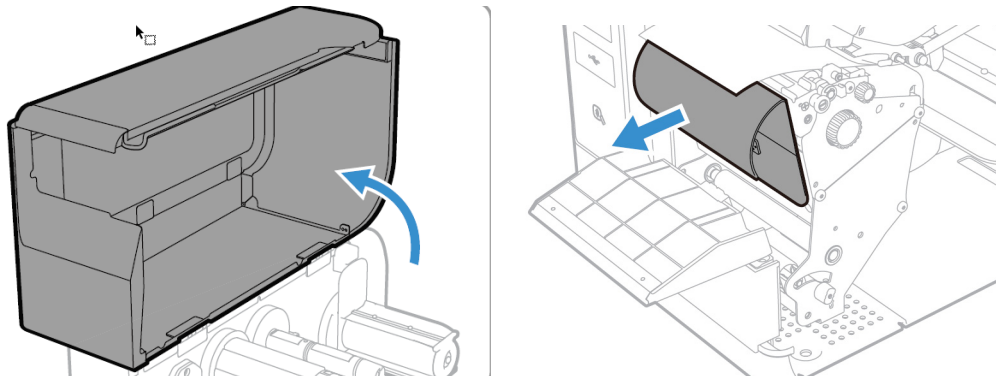

2. Turn the printhead lift lever counterclockwise to raise the printhead and lift the front arm or verifier arm.

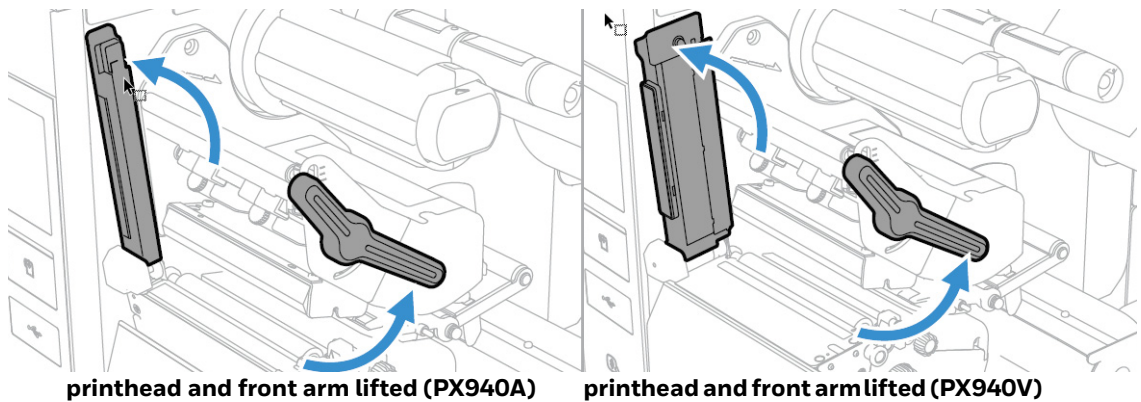

3. Load a media roll onto the media supply hub.

Note: Make sure you push the roll all the way against the inner wall of the printer.

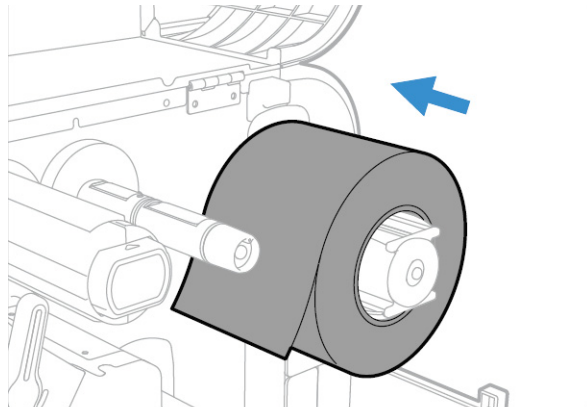

4. Insert the media roll holder and tighten the screw.

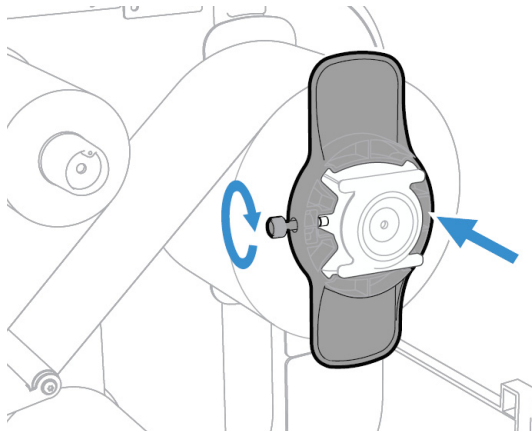

5. Route the media through the print mechanism, through the front arm.

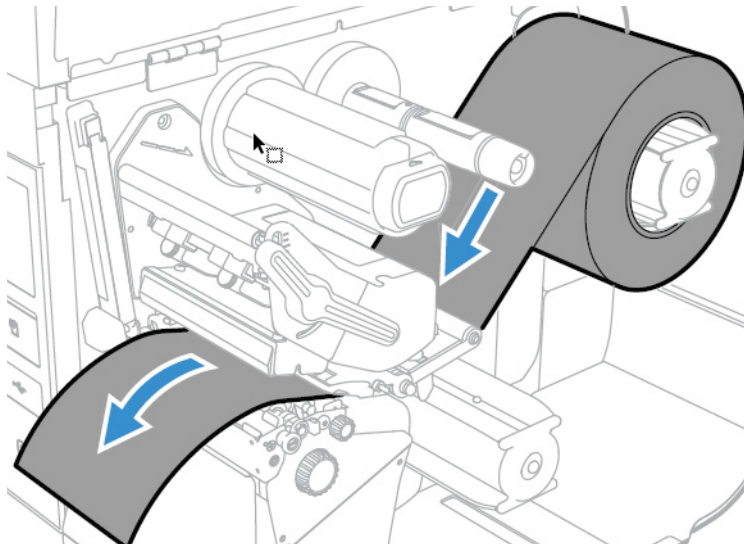

6. Adjust the media and dancer guides to hold the media in place.

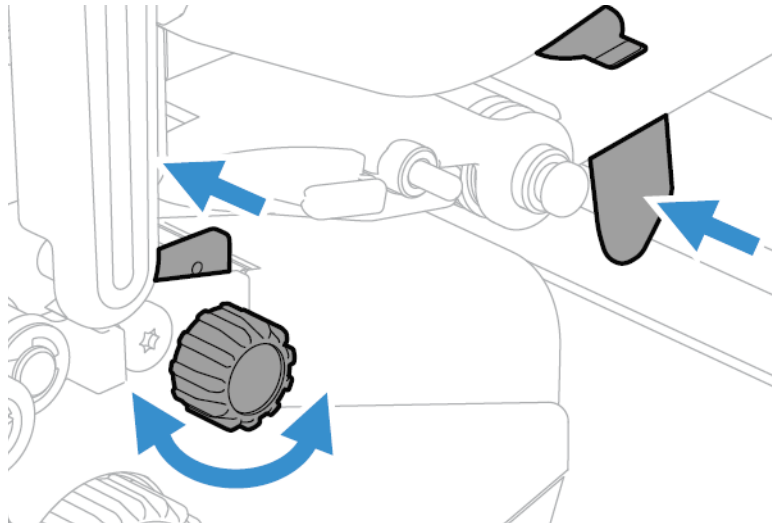

Note: There is a media guide that is located near the printhead. It is recommended to adjust the media guide all the way to the right in order to insert the media. If not, it can be difficult to load the media.

7. Adjust the label gap and black mark sensor. The sensor blue LED should line up with the center of the media.

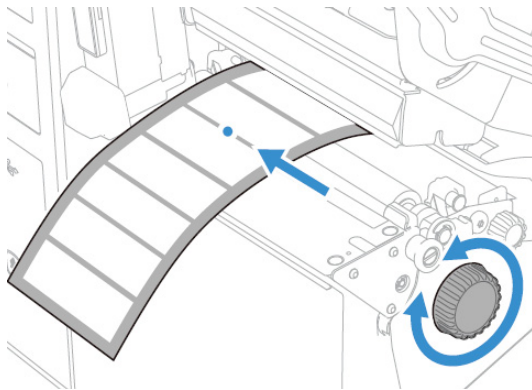

8. Turn the printhead lift lever clockwise to close the printhead and lower the front arm and click into place.

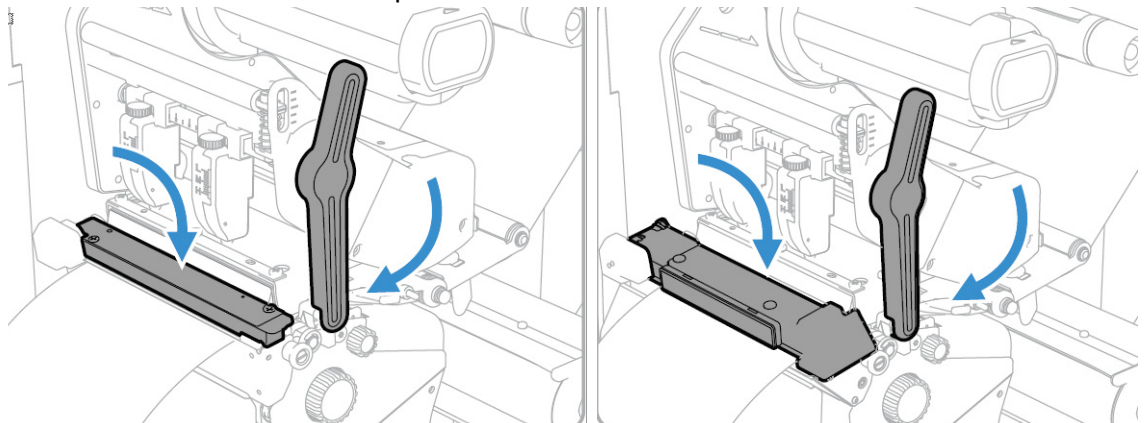

front arm in place (PX940A)

front arm in place (PX940V)

9. Press the **Print** button to advance the media.
10. Close the media cover.

Load Media for Rewind Printing

Follow steps 1-9 from Load Media for Tear-Off Printing, then:

1. Place the rewinder batch plate back on the printer.

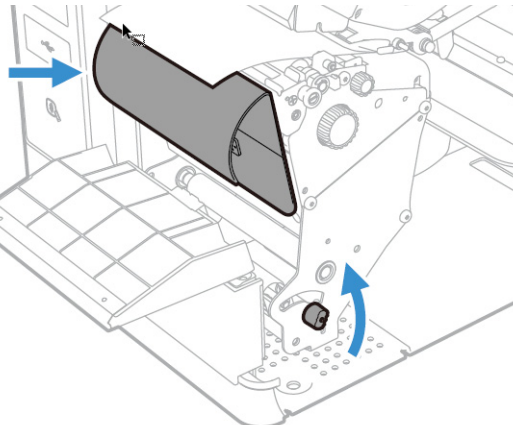

2. Insert an empty media core onto the rewinder take-up hub.

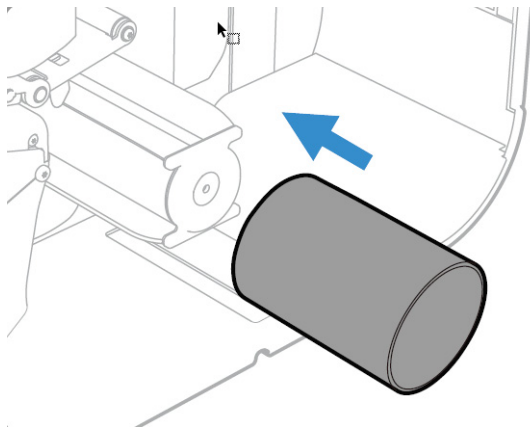

3. Round the media through the rewinder batch plate and tape leading edge of label to the empty media core to secure position.

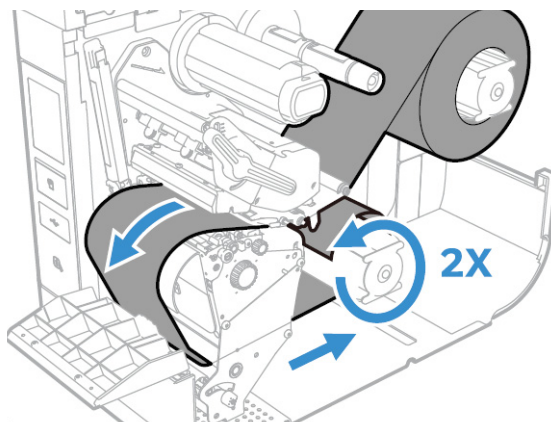

4. Route the media around the media rewriter.
5. Lock the Rewind/Liner Take-Up knob into closed position.
6. Put media roll holder in place.
7. Go to **Main Menu > Setting > Printing > Media > Printing Mode**, select **Rewind** from the list.

Note: Honeywell recommends using non-perforated labels when using rewinder mode.

Load Media for Peel-Off Printing

Follow steps 1-9 from Load Media for Tear-Off Printing, then:

1. Insert the media in the opening between the label dispenser and the platen roller.
2. Insert an empty media core onto the rewriter take-up hub.

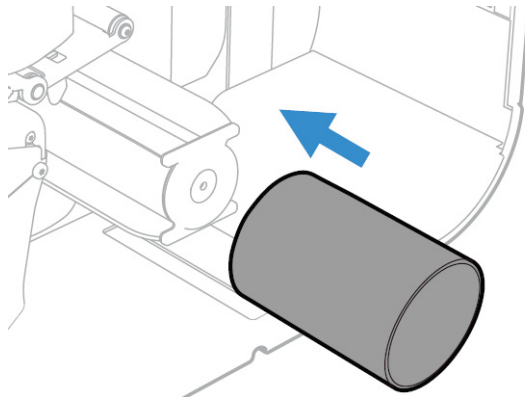

3. Round the liner through the media rewriter and tape leading edge of label to the empty media core to secure position.

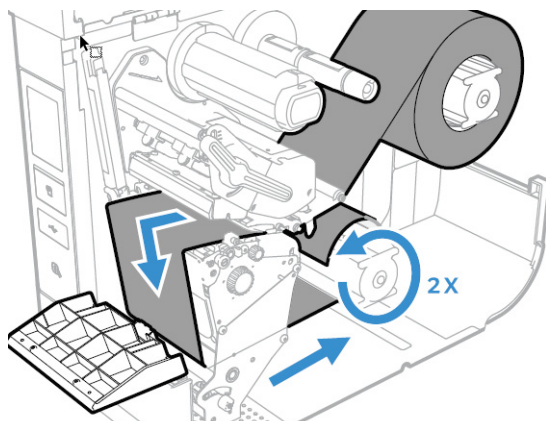

4. Pull the liner tight and lock the Rewind/Liner Take-Up knob into closed position.

- Put media roll holder in place.

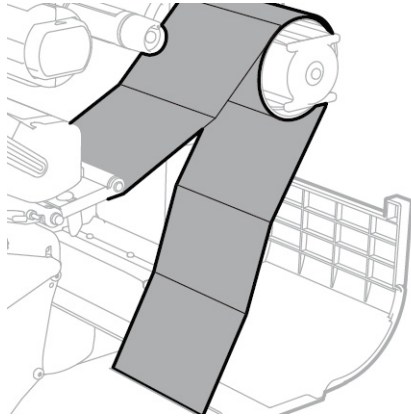

- Go to **Main Menu > Setting > Printing > Media > Printing Mode**, select **Peel-Off** from the list.

Note: Honeywell recommends using non-perforated labels when using peel-off mode.

Load Fanfold Media

Note: Before loading fanfold media, insert an empty media core onto the rewinder take-up hub.

To load Fanfold Media from behind the printer:

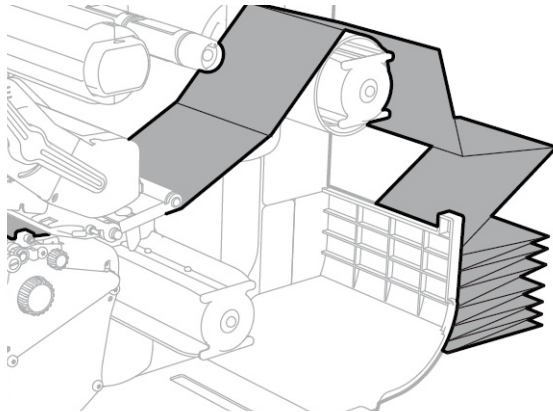

To load Fanfold media from bottom access slot:

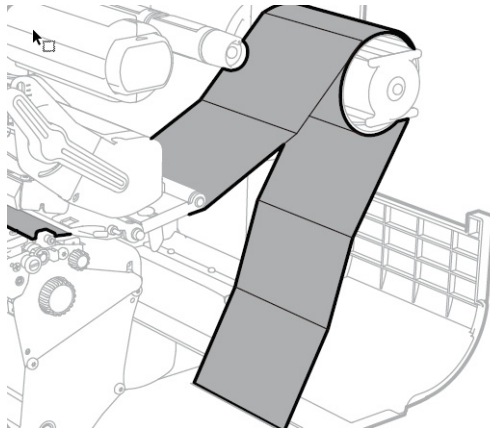

About the Ribbon

Thermal transfer printing provides a durable printout that is less vulnerable to chemicals, heat, and sunlight than direct thermal printing. Select a ribbon type that matches the media you are using and configure the printer for thermal transfer media.

The printer supports thermal transfer ribbon rolls with the ink-coated side facing either inward or outward. To determine which type of ribbon you have, place the ribbon on a piece of paper as shown, and use a pen or other sharp object to scratch the ribbon. If you see a mark on the paper, your ribbon is wound ink out.

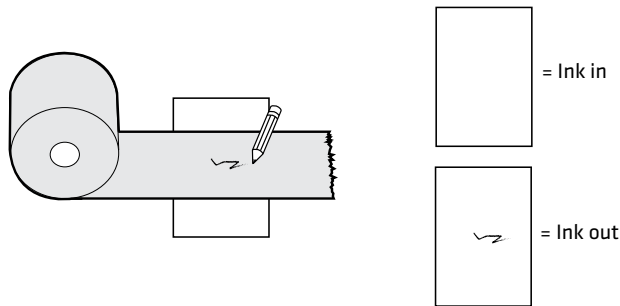

Load Ribbon

1. Open the media cover.
2. Turn the printhead lift lever counterclockwise to raise the printhead and lift the front arm.
3. Slide the ribbon roll onto the ribbon supply hub.

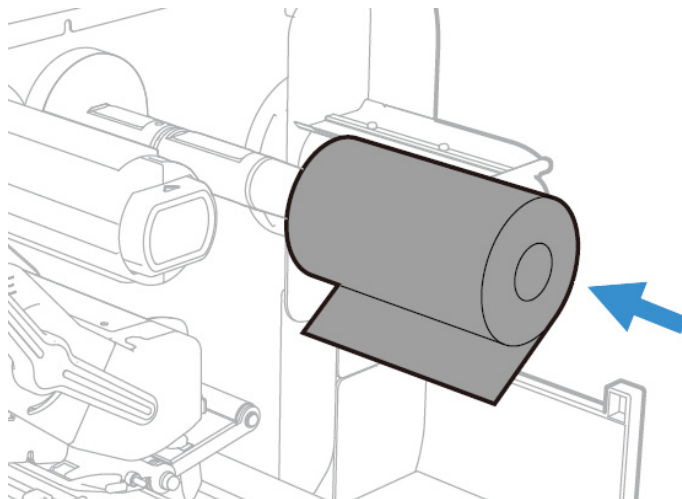

Note: For ribbon that has the ink wound out, place the ribbon on the ribbon supply hub with the ribbon wound clockwise. For ribbon that has the ink wound in, place the ribbon on the ribbon supply hub with the ribbon wound counterclockwise.

4. Route the ribbon through the print mechanism and pull out approximately 8 inches (20cm) of ribbon leader.

The dotted line in this illustration shows how to load ribbon with the ink wound in.

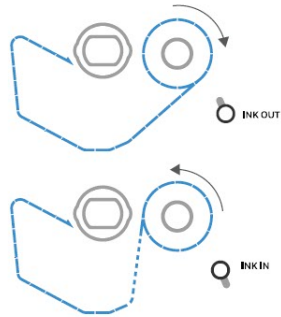

5. Turn the ribbon take-up hub counterclockwise until the ribbon becomes tight and runs wrinkle-free through the print mechanism.
6. Set the Ribbon Selector switch to **Ink In** or **Ink Out**.
7. Close the media cover.

Note: Ensure that the knob at the take up is not pushed in during rewinding. This can cause difficulty removing the ribbon when full.

Ribbon Removal

Remove used ribbon from the ribbon take-up hub when you change the roll of ribbon. Remove the used ribbon each time you change a new roll of media if the ribbon is less than the width of the printhead.

To remove the used ribbon:

1. Break/tear the ribbon before the ribbon take-up hub.

Note: Do not cut the ribbon on the ribbon take-up hub; doing so may result in damage to the take-up hub.

2. Push and hold the ribbon release knob until it stops.

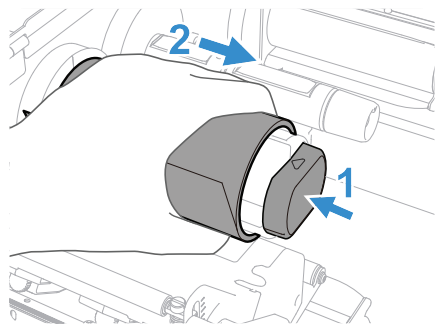

Note: Do not push the ribbon release knob in if you do not want to remove the used ribbon as this will cause difficulty to remove ribbon when full.

3. Push the two ribbon release plates and slide the used ribbon from the ribbon take-up hub.

Print a Test Label

The first time you turn on the printer or reset to factory defaults, the printer runs a startup wizard to let you enter basic setup information. After the startup wizard finishes, the printer enters Ready mode where you can access the Main Menu and print a test label.

1. Connect the printer to power and turn on the printer.
2. After the startup sequence finishes, the startup wizard begins. Enter all the information on the wizard screens then tap **No** when prompted to run other wizards.

3. From the Ready screen, press  to view the Main Menu.

4. From the Main Menu, tap **Tools > Test Labels**.

5. Select the test label you want to print and tap it.

Your test label prints. If print quality is low, go to **Wizards > Printing > Print Quality**.

Note: You can use command languages, like [Direct Protocol](#), and language simulators, like [ZSim](#), to create and print labels. For more information, see the command reference manual for the language.

Printhead Pressure and Toggle Position

Pressure Adjustment

You may need to adjust the printhead pressure on the printer if:

- You are using thicker or thinner media than previously.
- Your thermal transfer ribbon starts to crease.

Do not use a higher printhead pressure than necessary. It may increase wear and shorten the life of the printhead.

1. Use your finger to turn the wheel to adjust pressure.
 - Rotate the wheel clockwise to increase the pressure resulting in darker print.
 - Rotate the wheel counterclockwise to decrease the pressure resulting in lighter print.

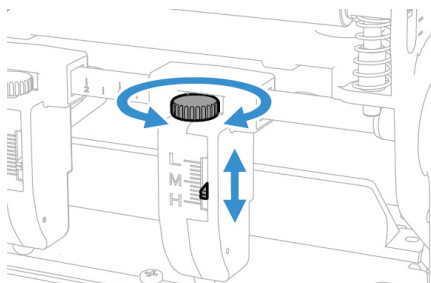

2. Test for Print Quality

Note: Marking on the toggle, “L”: Light pressure; “M”: Middle pressure; “H”: High pressure.

Toggle Position Adjustment

If the toggles are not adjusted in the correct position or do not apply the correct pressure, the following issues may occur:

- Labels print lighter on one side than the other
- Media and ribbon may slip
- Ribbon may wrinkle
- Media may move from side to side during printing

If any of these things occur, you probably have an unbalanced printhead. The printer is adjusted at the factory for full-width media.

If you are using media that is less than full-width (4 inches or 102mm), adjust the position of the toggle as necessary to provide the even pressure on the media.

Toggle Settings

Item	Scenario	Printhead Toggle Setting
1	Thin media or the media and ribbon requires lower pressure to print well or DT media	Thin media or the media and ribbon requires lower pressure to print well or DT media
2	Thick media or the media requires high pressure to print well	Increase the pressure on both left and right toggles.
3	Light Printing on the left side of the label	Increase the pressure on the left toggle.
4	Light Printing on the right side of the label	Increase the pressure on the right toggle.
5	Media moves from left side to right side during printing	Increase the pressure on the left toggle or decrease the pressure on the right toggle.
6	Media moves from right side to left side during the printing	Increase the pressure on the right toggle or decrease the pressure on the left toggle.
7	Media and ribbon slippage during printing at retract mode	Increase the pressure on both left and right toggles.
8	Narrow media (less than 2inch)	Move the left toggle to the center of the media and decrease the pressure on the right toggle.

CONNECT THE PRINTER

This section contains information about connecting the printer to a PC or to a network. Use the [From the Printer Web Page](#) or the Main Menu to configure settings.

Connect the Printer to Your PC

You can connect the printer to your PC using one of the following methods.

Connect the Printer Using a Serial Cable

You can use a serial connection to communicate with your PC and send commands directly to the printer through a terminal connection.

1. Connect one end of the DB9 to DB9 RS-232 cable to the back of your printer and connect the other end to a serial COM port on your PC.

Connect the Printer Using a USB Cable

Connect only one printer to your PC, either directly or through a hub. You do not need to set up any parameters for USB communications.

1. Download and install the InterDriver software on your PC (see [Install Honeywell Windows Driver](#)).
2. When prompted, connect one end of the USB Type A cable to the back of the printer and connect the other end to your PC.

Connect the Printer to Your Network

These network interfaces provide features such as security, FTP/SFTP server, web page, and Alert handling.

Connect the Printer to an Ethernet Network

Use the Ethernet port to set up your printer as a network printer. The printer is set to automatically retrieve an IP address from the network (DHCP) when you turn the printer. You can use the network connection with InterDriver. You can also use it to send commands directly to the printer through a terminal connection (Telnet), or through FTP/SFTP.

Note: To enable the FTP/SFTP from the webpage, go to **Configure > System Settings > Manage Service**.

1. Turn the printer off.
2. Connect the Ethernet cable to the Ethernet port in the rear of the printer and connect the other end of the cable to your network.
3. Turn the printer on.
4. If your printer uses a DHCP server to assign IP addresses, the IP address appears in the lower left corner of the screen.
5. If you are not using a DHCP server to automatically assign IP addresses to devices in your network, you must set a static IP address and other network information manually. Continue with the next step.
6. For a non-DHCP network:
 - From the Main Menu select **Settings > Communications > Ethernet > IPv4 or IPv6** and change the settings as needed.

Setting	Default
(IPv4) IP Assignment Method	DHCP
(IPv4) IP Address	0.0.0.0
Subnet Mask	0.0.0.0
Default Router	0.0.0.0
DHCP Response	Broadcast
(IPv6) IP Assignment Method	Automatic
(IPv6) IP Address	Automatic

Configure Bluetooth Communications from the Web Page

The printer must be connected to an Ethernet or wireless network and you must know the printer IP address.

1. Open a web browser on your PC and click **Login**
2. Type your Username and Password and click **Login**.
3. Click the **Configure** tab. The Configuration Summary page appears.
4. Click **Communications > Bluetooth**. The Bluetooth settings page appears.
5. Change Bluetooth settings as needed. You can also click **Default Settings** to restore all default Bluetooth settings.
6. Click **Save**.

Configure Bluetooth Communications from the Main Menu

Use this procedure to configure Bluetooth settings from the printer Main Menu. You may need to configure these settings if you want to connect to a mobile computer through Bluetooth.

1. Press the **Main Menu** button.
2. Select **Settings > Communications > Bluetooth**.
3. Change settings as needed for your Bluetooth device.
4. Tap **Save**.

Connect the Printer via Wi-Fi

The printer supports wireless communications when the optional Wi-Fi module is installed.

You can configure wireless communications:

- From the printer web page.
- From the printer Main Menu.

By default, the printer supports DHCP networks.

Note: *If you are not using a DHCP network, Wi-Fi settings must be configured by using Honeywell PrintSet 5 through a USB connection to the printer. Send commands through a serial connection, or use the wizards and settings menus on the printer.*

Configure Wi-Fi Communications from the Web Page

Use this procedure to configure wireless communications from the printer web page.

Note: *The printer must be turned on and connected to your Wi-Fi or Ethernet network to configure the printer from the web page.*

1. Open a web browser on your PC.
2. In the address bar, type the IP address of your printer and press Enter. The printer web page appears.
3. Click **Login**.
4. Type your Username and Password and then click **Login**. The default value for Username is **itadmin** and the default value for Password is **pass**.
5. Click the **Configure** tab. The Configuration Summary page appears.
6. Click **Communications > Wireless 802.11**. The Wireless 802.11 settings page appears.
7. Change wireless settings as needed. You can also click **Default Settings** to restore all default Wireless 802.11 settings.
8. Click **Save** when you are finished.

Configure Wi-Fi Communications from the Main Menu

You can configure wireless communications using the Wireless 802.11 wizard or from the Main Menu.

1. Press the Main Menu button.
2. Select **Settings > Communications > Wireless 802.11**.
3. Change settings as needed for your wireless connection.
4. Tap **Save** when you are finished.

Install Authentication Certificates

If you are using Wireless 802.11 security, you may need to install authentication certificates in the printer for the highest level of security.

1. Configure the printer for the correct date and time.
2. On your PC, open an FTP/SFTP connection to the IP address of the printer.
3. Transfer your certificate to `/home/user/certificates/public`.
4. On your PC, open a Telnet session to the printer.
5. Change the directory to: **`/home/user/certificates/public`**.
6. Type the command: **`ls -la`**.
7. You should see the certificate that you transferred in step 3.
8. Use the `certinstall` script to install the certificate using this format:
`<prompt> certinstall.sh <certificate name>`

Example: `itadmin@PX940-00000000073 /home/user/certificates/public$certinstall.sh entrust.cer`

9. When you receive confirmation that the certificate was installed, type this command to make sure you see a .pem file and another soft link to the same file: **`ls -la`**.

Note: Use the printer web page the Main Menu, or Honeywell PrintSet 5 to specify the certificate .pem file to use for security.

Printer Drivers

Before you can use the printer with Microsoft® Windows® printing applications, you must install printer driver software on the PC. Drivers enable the printer to communicate with your PC and with printer software applications.

You can access the Honeywell Technical Support Downloads portal at: <https://hsmftp.honeywell.com>. Click on **Software > Printers > Printer Software and Drivers**)

Note: Although Windows may auto-detect the printer when you connect it to a PC through a USB port, you still need to install printer drivers on the PC for the printer to operate correctly.

Install Honeywell Windows Driver

Use InterDriver to install printer driver software on your PC.

Note: Although Windows may auto-detect the printer when you connect it to a PC through a USB port, you must still install printer drivers on the PC for correct printer operation.

1. Access the Honeywell Technical Support Downloads portal at <https://hsmftp.honeywell.com>.
2. Download Honeywell Software Download Manager by clicking **here** in the web page. Install the Download Manager.
3. Click on the **(+)** to expand the list. Then go to **Software > Printers > Printer Drivers > Honeywell Windows Driver**.
4. Open the Honeywell Software Download Manager and follow the instructions to download the file.
5. Extract the driver files to a location on your PC.
6. Double-click the .exe file to install InterDriver and follow the prompts to complete the installation.

USB Host Port

Use the USB host interface port on the printer to connect these peripheral devices:

Device	Description
Keyboard	Use a standard USB keyboard to send Fingerprint printer language commands directly to the printer or to enter information if you are running a Smart Printing application.
Barcode scanner	Use USB barcode scanners for data input with a Smart Printing application. The printer also supports other USB scanners that use a generic keyboard driver.
USB storage device	Use a USB storage device to load applications, configuration files, fonts, and images into the printer memory, or to perform firmware upgrades. You can also save configuration files to a USB storage device for upload to a printer. The USB storage device must have a single partition and be formatted as FAT16 or FAT32.

You can also connect a peripheral device through the USB-to-Serial or USB-to-Parallel adapter cable accessories. Contact your local sales representative for information.

Connect a USB Device

A USB storage device can be inserted into the USB host port on the front of printer or into the USB host port on the back of the printer.

1. If you are connecting a USB storage device, make sure the device has a single partition and is formatted as FAT16 or FAT32.
2. Connect the device to one of the USB host ports.
3. If you connected a USB storage device to an LCD printer, select **Tools > USB Menu** for more options.

CONFIGURE THE PRINTER

Use one of these methods to view and change printer settings:

- Printer web page
- Main Menu
- PrintSet 5
- Print Set MC
- Programming commands

Printer Configuration Menus

The structure of the printer configuration menus is consistent among the different interfaces. The same organization appears whether you are accessing the menus through the web page or the printer Main Menu. There are four main printer configuration menus for each interface:

- Printing
- System Settings
- Verification Settings (PX940V only)
- Alert

Use the following table to understand where information is located in the printer configuration menus. Not all configuration items appear in each type of interface.

Configuration Menu	Description
Printing	Media and Print Quality
System Settings	General, Display, Audio, Manage I/O, Manage Services, and Maintenance Alerts
Verification Settings	Verification Settings
Alerts	Error, Warning, and Information
Communications	General, Security, and Network

Printer Configuration

Configure the Printer from the Main Menu

You can view or change the configuration settings by pressing the **Settings** button from the Main Menu.

1. From the Ready screen, press the Main Menu button.
2. From the Main Menu, press the **Settings** button. The Settings menu appears.
3. Select the settings you want to configure and make your changes.
4. Save your changes when prompted.

Restrict Access to the Main Menu

By default, all menus are available from the Main Menu the first time you turn on the printer. If necessary, you can require a PIN to restrict access to menus or you can disable access to all menus.

Menu Access Setting	Description
Enable (default)	All users can access the menus from the Main Menu and from the USB flash drive menu.
Enable with PIN	Users need to enter a PIN to access the Main Menu or USB flash drive menu.
Disable	Users cannot access the menus from the Main Menu or from the USB flash drive menu.

1. Go to the Display menu for the printer:
 - From the web page (see [Smart Printing](#)), select **Configure > System Settings > Display**.
 - From the Main Menu screen, select **Settings > System Settings > Display**.
2. Select a Menu Access setting and save your changes.
3. If you select **Enable with PIN**, you also need to type in a PIN and save your changes.

Access the Printer Web Page

4. Open a browser window on your PC.
5. In the location or address bar, type the printer IP address and press **Enter**. The printer web page appears.
6. Click **Login**. The login page appears.

Printer Webpage User Name and Password

You will be prompted for a user name and password. The default username is **itadmin** and the default password is **pass**. Once you login, you have the option to change the user name and password.

Configure the Printer from the Web Page

If you are using Ethernet or Wi-Fi communications, you can change configuration settings from the web page of the printer. Connect the printer to your network and obtain an IP address.

1. Open a web browser on your PC.
2. In the address bar, type the IP address of your printer and press **Enter**. The printer web page appears.
3. Click **Login**. The Login page appears.
4. Type your Username and Password and then click **Login**. The default value for Username is **itadmin** and the default value for Password is **pass**.
5. Click **Configure**. The Configuration Summary page appears.
6. To see a complete list of printer settings, click **Configuration Summary**.
7. To configure printer settings, click an item in the navigation pane:
 - For serial, Ethernet, Wireless 802.11, or Bluetooth LE settings, click **Communications**.
 - For media or print quality settings, click **Printing**.
 - For display, audio, service, and general settings, or maintenance alert message triggers click **System Settings**.
 - To set conditions that trigger error, warning, and information alert messages, click **Alerts**.
 - For network-related settings (such as DNS, WINS, Net1), for web and email server information, or if you are using a network management application, click **Network Services**.
8. Make any changes to the settings you want to configure.
9. To save your changes, click **Save**.
10. To reset all parameters on the page to the default settings, click **Default Settings**.

Configure the Printer with PrintSet 5 or Print Set MC

You can use PrintSet 5 or Print Set MC to change configuration settings on your printer. Download the PrintSet 5 or Print Set MC from the App Store on iOS or Google Play Store on Android devices.

You can download Honeywell applications to extend the capabilities of the printer. You may need to purchase a license to run some applications. To learn more about, licenses and other Honeywell software solutions, go to sps.honeywell.com > **Software**.

Support for Honeywell Safety and Productivity Solutions products is available online through the Technical Support Portal.

Configure the Printer with Programming Commands

You can change configuration settings by sending programming commands directly from your PC to the printer through a terminal program (such as HyperTerminal), a serial connection, or a network connection.

If your printer uses the Fingerprint programming language, use the SETUP command followed by the node, subnode, and parameter setting.

You must log in as an itadmin to perform a SETUP operation, but you do not need to log in to perform a SETUP GET operation.

Note: For more information on how to change configuration settings with a programming language, see [Printer Command Languages and Simulator Support Options](#), beginning on page 6.

Uploading from the Web Page

You can use the printer web page to install fonts, images, applications, formats, and web forms to the printer.

1. Open a web browser on your PC.
2. In the address bar, type the IP address of your printer and press **Enter**. The printer web page appears.
3. Click **Login**. The Login page appears.
4. Type your Username and Password and then click **Login**. The default value for Username is **itadmin** and the default value for Password is **pass**.
5. Click the **Manage** tab. The Overview page appears.
6. Click on the desired item in the Overview list. The upload page appears for the option you selected.
7. To upload a file to the printer, click **Browse** to locate your file. Double-click the file to select it, then click **Upload**. The file uploads to the printer.
8. Click **Save** when you are finished.

Uploading from a USB Storage Device

You can use a USB storage device to install fonts, images, applications, formats, and web forms to the printer. Use this table to understand where your files need to be located on the USB storage device for the printer to install them.

File Type	Directory to Place the File	Installed in this Printer Directory
Application	/apps	/home/user/apps
Configuration	/config	
Configuration profile	/profiles	/home/user/profiles
Display images	/display	/home/user/display
Fingerprint script	/scripts	/home/user/scripts
Firmware	/firmware	
Font	/fonts	/home/user/fonts
Form/layout	/forms	/home/user/forms
Printed images	/images	/home/user/images
Installation package (UFF file)	Root of USB storage device	
Start file	Root of USB storage device	
Web Form	/webforms	/home/user/webforms

1. Copy your files to a USB storage device using the directories in the table.
2. Insert the USB storage device into one of the USB host ports on the printer.
3. The USB Device menu automatically appears:
 - a. Select **Install Resources**.
 - b. Select the file you want to install and wait until the item turns gray and a checkmark appears next to it. The file is now successfully installed in the printer.
 - c. Continue to another file if you have more files to install.

Change Background Image for the Ready Screen

You may customize the Ready screen that appears on the printer. The background image you create must be:

- 320 x 240 pixels.
 - named **background_idle.png**.
1. Create a /display directory on your USB storage device.
 2. Copy your **background_idle.png** file to the **/display** directory on the USB storage device.

3. Insert the USB storage device into one of the USB host ports on the printer.
4. Use the USB Device menu to upload the file to the printer.
5. Restart the printer.

The new image file you uploaded appears in place of the original Ready screen.

Printer Profiles

You can save updated printer default settings as a printer profile. The printer supports multiple profiles that can be saved and loaded at any time. For example, you can create one profile to use when you are printing on continuous label stock, and a different profile to use when you are printing on label stock with gaps.

The following printer settings are not saved in a profile:

- IP address for either IPv4 or IPv6 networks
- Media calibration settings for the label stop sensor
- Remote port or remote host values for a remote computer accessing the printer through raw TCP

Save a Printer Profile from the Web Page

From the printer web page, you can save the current settings as a profile that you can load from the printer memory at any time.

1. In the printer web page (see [Access the Printer Web Page](#)), click the **Configure** tab.
2. Click **System Settings > General**.
3. Click **Save As Profile**. The Save As Profile screen appears.
4. Enter a name in the Profile field, and then click **Save**.

Load a Printer Profile from the Web Page

You can load a saved profile from the printer web page.



1. In the printer web page (see [Smart Printing](#)), click the **Manage** tab.
2. Click **Profiles**.
3. The Resident list includes profiles that are saved in the printer memory.
4. To load a profile from the printer memory, select the profile in the Resident list and then click **Activate**. The profile is loaded.
5. To load a profile from another location, click **Browse** and browse to the location of the file. Double-click the file to select it, then click **Upload**. The profile is uploaded to the printer.

Save a Printer Profile from the Main Menu

Use this procedure to save the current settings as a printer profile.



1. From the Ready screen, press the Main Menu button. The Main Menu appears.
2. Select **Tools > Profiles**. The Profiles menu appears.
3. Select **Create**. The Create Profile menu appears.

Note: *selecting Create acts as the Save function*

4. Select the **Filename** text box and type a name for the profile. The profiles can have up to sixteen characters.
5. Press  on the SIP to save your profile name and go back to the Save Profile menu.
6. Press  and wait until **Complete** appears on the screen.
7. Press  to return to the Main Menu.

Load a Printer Profile from the Main Menu

Use this procedure to load a saved printer profile on the printer.

1. From the Ready screen, press the Main Menu button. The Main Menu appears.
2. Select **Tools > Profiles**. The Profiles menu appears.
3. Select **Load**. The Load Profile menu appears.
4. Select the profile you want to load on the printer and press .
5. When **Complete** appears on the screen, press  to return to the Main Menu.

Load a Printer Profile Using Programming Commands

You can load a saved printer profile to another printer by sending programming commands directly from your PC to the printer through a terminal program (such as HyperTerminal), a serial connection, or a network connection. All commands are case-sensitive.

Note: *To load printer profiles that modify communication settings that require itadmin rights, you must log in as an itadmin: RUN "su- p pass itadmin" for FD/DP.*

Connection	Programming Commands
Printer running Fingerprint	RUN "/system/usr/bin/cfg -o xmlimportset -k /home/user/profiles/myprofile"
Printer running IPL	<STX><ESC>.x,/system/usr/bin/cfg -o xmlimportset -k /home/user/profiles/myprofile<ETX>
Telnet connection over Port 23	/system/usr/bin/cfg -o xmlimportset -k /home/user/profiles/myprofile

Install a Configuration File from a USB Storage Device

After you save an .xml configuration file to a USB storage device, you can install it on the printer at any time.

1. Insert the USB storage device in the printer USB host port.
2. From the Ready screen, press the Main Menu button. The Main Menu appears.
3. Select **Tools > USB Menu**.
4. Select **Configuration**.
5. Select **Install Configuration**. The printer imports the configuration file.
 - For most printer languages, the configuration file is imported directly into the working configuration and is not copied to the /config directory.
 - An IPL configuration file is copied to /home/user/config/ipl.
6. Press **OK** when the confirmation message appears.

Export a Configuration File to a USB Storage Device

You can save an .xml configuration file to a USB storage device and install it on other printers.

1. Make sure the USB storage device has a single partition and is formatted as FAT16 or FAT32.
2. Insert the storage device into the printer USB host port.
3. From the Ready screen, press the Main Menu button. The Main Menu appears.
4. Select **Tools > USB Menu**.
5. Select **Configuration**.
6. Select **Export Configuration**. A list of the available files appears.
7. Select the file to export.
8. Press **OK** when the confirmation message appears.

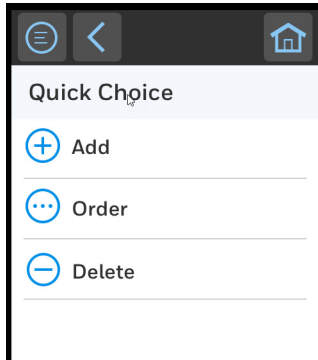

Menu Shortcuts

You can create shortcuts to access frequently used menus or items, such as profiles, applications, test labels, and wizards. These shortcuts are added to a Quick Choices menu, which replaces the Main Menu.



The Main Menu appears as the first item in the Quick Choice menu. Items in the Quick Choice menu appear in the order in which they are added. The Main Menu always appears as the first item.

Menu shortcuts can be very useful in these situations:

- You need to frequently change media. Create a profile for each media type and create shortcuts for each profile. To quickly change the printer media settings, press the Main Menu icon  from the Ready screen to display the Quick Choice menu, then select the appropriate media profile.
- You frequently run Smart Printing applications. Create a shortcut for each Smart Printing application. To access these applications, press the Main Menu icon  from the Ready screen to display the Quick Choice menu, and select the appropriate application.

Create Menu Shortcuts

1. From the Main Menu, select **Tools > Quick Choices > Add**.
2. To load a profile:
 - a. Select **Load Profile**.
 - b. Select **Load Profile** again and a check mark appears in the box.
 - c. Select the arrow at the bottom of the screen.
 - d. Select the check mark icon at the bottom of the screen.
3. To select applications:
 - a. Select **Programs**.
 - b. To add a Program, select each program and a check mark appears in each box.
 - c. Select the check mark icon at the bottom of the screen.

4. To select test labels:
 - a. Select **Tools**.
 - b. Select **Test Labels**.
 - c. To add individual test labels, select each test label option and a check mark appears in each box.
 - d. Select the check mark icon at the bottom of the screen.
5. To select wizards:
 - a. Select **Wizards**.
 - b. To add individual wizards, select each wizard and a check mark appears in each box.
 - c. Select the check mark icon at the bottom of the screen.
6. The next time you press the Main Menu icon  from the Ready screen, the Quick Choice menu (containing the Main Menu and your menu shortcuts) appears.

Customize the Printer Web Page

The printer web page visual presentation is specified using a CSS (Cascading Style Sheet). The printer web page loads the default style.css.

There are two ways to customize the printer web page:

- Adjusting layout style
- Replacing complete standard web pages

To adjust the style sheet:

1. Retrieve the default CSS file from the printer: `http://<printerip>/format/style.css`.
2. Modify the style sheet and save your changes.
3. Upload the style sheet to the printer via `/home/user/webpage/style.css`.

The layout and structure of the printer web page is the same throughout each of the different pages. Below is an overview of how the web page looks with three different main components that always exist:

Area	Description
Left-Menu Navigation define in mainmenu.lua	For each of the pages, this area will show links to more detailed pages depending on which section is currently shown. On the Home Page this area will show the current status of the printer.
Right Top Bar define in maintop.lua	Displays the information about the printer/login/language as well as printer's status.
Main Content	Here is where all the content is displayed to the user.

The verifier identifies and verifies the barcodes in printed outputs using supported command languages. When media is printed, the verifier ensures barcode readability and quality.

Note: *Do not power off the printer during printing/verification. This can result in loss of verification reports.*

Setting up the Verifier

The verifier can be configured through the webpage by clicking on **Configure > Verification Settings** or through the front touch panel, **Settings > Verification Settings**.

Webpage

The supported features are listed as the following:

- Verification configurations
- Verification statistics
- Restore default verification database and failed label image files
- Verification reports for download

Front Panel

The supported features are listed as the following:

- Verifier Calibration Wizard
- Verification Results: allows the user to browse through all the barcodes and detailed results of the last label printed.
- USB port to export all verification reports and saved label image files.

Calibration

Calibrating the verifier maintains the accuracy of the verifier when scanning an image. Calibration is performed prior to the shipment of the printer, but can also be done with the calibration card.

Note: Honeywell recommends calibrating the verifier every six months for maximum performance.

Verifier Calibration Card

The calibration card is used to calibrate the verifier. It is very important to follow the instructions on the calibration card packaging for proper care of the calibration card. If you lose your calibration card, visit sps.honeywell.com and navigate to the PX940 printer product page.

Handling Instructions

- When not in use, keep the calibration card inside its original packaging, away from direct light exposure and stored at room temperature
- Keep calibration card clean.
- Use a dry cloth to remove any dirt if needed.
- Do not bend the card
- Do not perform verifier calibration if the card is damaged.

Note: DO NOT touch the section of the calibration card that is enclosed in the red box as shown below.

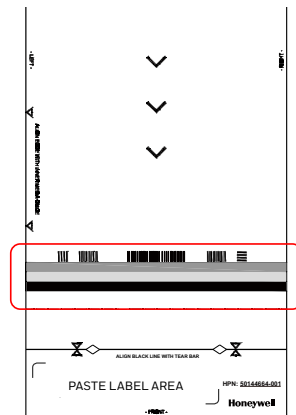

If your verifier is not calibrated, follow these steps:

Note: Do not power off the printer during verifier calibration.

Calibrating the Verifier

1. From the front touch panel, go to: **Wizards > Calibration > Verifier** and follow the instructions.
2. Open the verifier arm and print head arm.
3. Remove any media and ribbon from the printer media path.
4. Clean the printhead, platen roller, and verifier glass with a soft, lint-free cloth soaked in isopropyl alcohol.
5. Place the calibration card on the printer media path, according of the instructions written on the calibration card.
 - The three chevrons on the card indicating the orientation. The "FRONT" text on the card placed outside of the verifier
 - Align the black line with the printer tear bar. Use the diamond cut out on the calibration card black line to align to the tear bar.



Warning: The tear bar contains sharp edges. Keep fingers and other body parts away from the tear bar.

Note: You should see the tear bar through the diamond cut on the calibration card black line.

- Align the card evenly toward the printer spine and resting against the media guide.
6. Close the verifier arm and then the printhead.
 7. Press **NEXT** on the touch screen.
 - The card will move forward as the calibration process is running.
 8. Once completed, the front panel will show if the calibration pass or fail.

Note: If Calibration fails, see [Verifier Error Alerts and Solutions](#), beginning on page 76.

About Expired Verifier Calibration

The calibration data duration is six months.

When the verifier calibration has expired, a warning message will appear. You can dismiss the warning by pressing the **GO TO WIZARD** button. This will dismiss all calibration warnings until the printer is restarted.

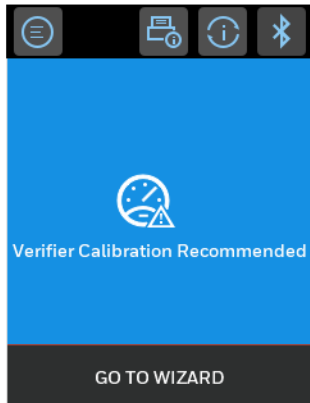

To determine your verifier calibration expiration date, visit the printer website.

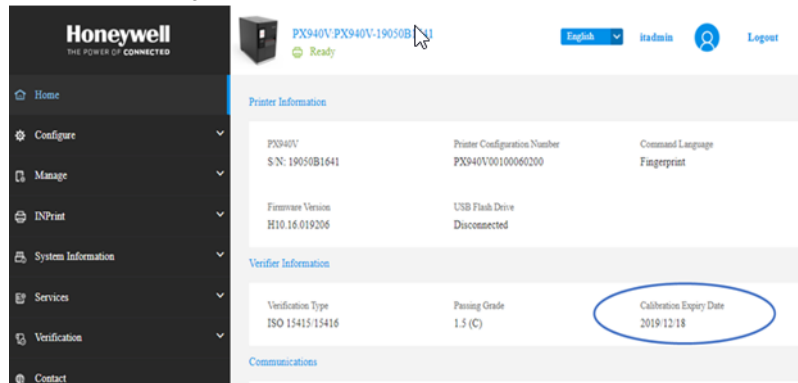

Verification Settings

This section gives a brief description of the verifier settings.

Verification Type

Select the verification type to check the barcode.

- None - No barcode validation
- Read/No Read - Validate if barcode is readable
- ISO15415/15416 - Full ANSI grading of barcode

Note: *In order to pass the readability check the following criteria need to be met:*

- Decoded data is the same as input data in the print script
- ANSI grading value is equal or greater than 0.5 (D)

Grading Override

When enabled, the user is allowed to decide to accept the failed label (below the grading threshold) when prompt for user action when maximum consecutive failures count is reached.

Report Level

Select the database logging level. The grade details only applicable for ISO 15415/15416 setting.

- Level 1 - No logging
- Level 2 - Label grade
- Level 3 - Label grade, and barcode grade
- Level 4 - Label grade, barcode grade, and barcode ANSI grading details
- Level 5 - All details including 10 scan line data

Passing Grade

Sets the minimum passing grade for barcode grading. Grade 0.0 (F) is the lowest grade. Grade 1.5 (C) is the default and recommended by ISO standard. Only applied when verification type is set to ISO15415/15416.

Aperture

Indicates the aperture size in mils (1000 mils = 25.4mm) used for verification. Aperture size will be chosen automatically based on ISO standard. Change only if required by an overriding application.

Maximum Consecutive Failures

Sets maximum number of times printer encountered verification failure consecutively before prompting for user action. This setting is only applicable when the Verification Failure Action is set to **Void and Reprint**.

Verification Failure Action

Indicates action to take when label fails verification.

- Void and Reprint (default) - Retract and void the failed label, then reprint the failed label. Stop reprint if the maximum consecutive failures have been reached.
- Ignore and Continue - No voiding when verification fails. Result is saved and next label is printed.

Note: *Note: During multiple label printing, printer will void the failed label (plus all printed and yet to be verified labels) in order to keep the good labels in sequence.*

Note: *During void and reprint process, the print job pause action is not supported.*

About Reprint Mode

Sequential		Non-Sequential (default)	
Example: Serialized Printing		Example: Batch Printing (all labels are the same)	
All good labels are in sequence	All Bad Labels are voided	Good labels may not be in sequence	All bad labels are voided
Advantage	Disadvantage	Advantage	Disadvantage
Good Labels are in the same sequence/order as sent to the printer	During voiding, extra labels may be voided to maintain sequence	Only bad labels will be voided	Good labels are not presented in order

Save Label Images

Selects the saving option for scanned labels. Label images and XML reports will be saved in non-volatile memory. A maximum of 100 images and XML reports can be saved (if memory available). When memory is full or maximum capacity is reached, oldest image and XML report file will be replaced by newest.

Available options:

- Disable
- Failed Labels only
- All Labels

Void Pattern

Select the void pattern type to mark the failed label.

Note: *The grid pattern makes the barcode non-readable whereas the diamond pattern is a visual void pattern.*

Note: *Grid pattern may cause media jam on certain special media configurations.*

Supported Command Language and Speed

Print verification works for the following mode:

- Printer command language: Autosense, FP/DP, ZSim, IPL, DPL

The maximum print speed supported when verifier is enabled:

- 10 ips for 203 and 300 dpi
- 6 ips for 600 dpi

The throughput of batch printing whether it can reached maximum print speed supported is depend on the following criteria:

- Communication interface (serial port, parallel port, USB, Ethernet, Wifi, etc.) used to send the print script

- Communication interface bandwidth
- Complexity of the label format which impact the rendering time
- Number of barcode in the label
- Barcode type, e.g. 2D barcode, Data matrix will took more time to process
- Size of barcode
- Location of barcode in the label (barcode located at the end of the label will be more impact to the throughput)
- Number of verification report in the database
- Level of verification report where a lower level of details in the report will require less space, faster to export and may increase throughput of batch printing
- Printer command language. Same label format printed in IPL will take longer time to generate compared to printed in FP/DP
- Label size where bigger label size will increase the scanned image size and take more time to transfer over the communication interface

Barcode Symbologies Supported

The verifier supports the following barcode symbologies:

- Code 39
- HIBC 39
- Code 128
- ISBT-128
- HIBC 128
- EAN-8
- EAN-13
- EAN-128
- UPC-A
- UPC-E
- Interleaved 2 of 5
- ITF-14
- Code 93
- Data Matrix (square and rectangular) ECC 200
- ISBT Data Matrix
- QR Code model 2 only

Supported Barcodes and Commands

This section lists all barcodes that support verification in different printer command languages, and the barcode specific ISO standard implemented. General ANSI grading is implemented according to ISO15415 and ISO15416.

No	Barcode Symbology	ISO Standard	Programming Commands			
			Fingerprint	ZPL	IPL	DPL
1	Code 128	ISO 15417-2007 (Code 128)	CODE128 CODE128A CODE128B CODE128C UCC128	^BC	c6,0,0 c6,0,1 c16,3 c16,6	E S W1I W1J Q R W1R
2	EAN 128	ISO 15417-2007 (Code 128)	EAN128 EAN128A EAN128B EAN128C	^BR	--	--
3	HIBC 128	ISO 15417-2007 (Code 128)	HIBC128	--	c16,0 c16,1 c16,2 c16,4 c16,5	--
4	ISBT 128	ISO 15417-2007 (Code 128)	ISBT128	--	c24	--
5	CODABLOCK (Single Row)	ISO 15417-2007 (Code 128)	--	^BB (Single row)	--	--
6	EAN-13	ISO 15420:2009 (EAN/UPC)	EAN13	^BE	c7,0,2	F
7	EAN-8	ISO 15420:2009 (EAN/UPC)	EAN8	^B8	c7,0,1	G
8	UPC-A	ISO 15420:2009 (EAN/UPC)	UPCA	^BU	c7,0,3	B
9	UPC-E	ISO 15420:2009 (EAN/UPC)	UPCE	^B9	c7,0,0 c7,0,4	C
10	Data Matrix	ISO 16022-2011 (Data Matrix)	DATAMATRIX	^BX	c17,200,0 c17,200,1	W1c/W1C
11	ISBT Data Matrix	ISO 16022-2011 (Data Matrix)	ISBTDM	--	--	--

No	Barcode Symbology	ISO Standard	Programming Commands			
			Fingerprint	ZPL	IPL	DPL
12	Code 39	ISO 16388:2007 (Code 39)	CODE39 CODE39A CODE39AC CODE39C CODE39AX CODE39AXC	^B3	c8,3 c8,6" c0,3/c0,4/c0,5 c0,6/c0,7/c0,8 c0,0/c0,1/c0,2	A H
13	HIBC 39	ISO 16388:2007 (Code 39)	HIBC39	--	c8,0 c8,1 c8,2 c8,4 c8,5	--
14	LOGMARS	ISO 16388:2007 (Code 39)	--	^BL	--	--
15	Interleaved 2 of 5	ISO 16390-2007 (Interleaved 2 of 5)	INT2OF5 INT2OF5A INT2OF5C INT2OF5D	^B2	c2 c15	D J
16	UPC SCC	ISO 16390-2007 (ITF-14)	UPCSCC	--	--	L
17	RSS14E/ DataBar Expanded	ISO 24724-2011 (GS1 DataBar)	RSS14E	--	c20,5	W1k E
18	Code 93	AIM-BC5-2000	CODE93	^BA	c1	O
19	QR Code	ISO 18004-2015	QRCODE	^BQ	c18,1	W1d/W1D

Barcode Orientations

- Picket or ladder orientation

Barcode Size Supported

- Minimum 1D barcode size: 10 mils
- Minimum 2D barcode size: 10 mils

Verification Length

Support maximum verification length up to 12 inches.

Maximum Number of Barcodes per Label

A total of 32 barcodes can be scanned and verified per label. If the number of barcodes on one label exceeds 32, the verifier system will show an error message.

Note: *Preprinted barcodes and barcodes sent as graphic print jobs will not be verified.*

Note: *Only barcodes generated by printer language commands are supported for verification.*

Printing Behavior after Error Recovery

Possible printer error during printing & verification:

- Printhead lifted
- Front arm lifted
- Next label not found
- Out of media
- Out of ribbon
- Ribbon installed

Printing Behavior after Recovered from error above:

1. No void printing. User will need to manually mark/discard the labels between the verifier module and printhead.
2. Reprint all unverified labels and verification failed labels.

The following diagrams show which labels will be reprinted in different scenarios.

Scenario 1

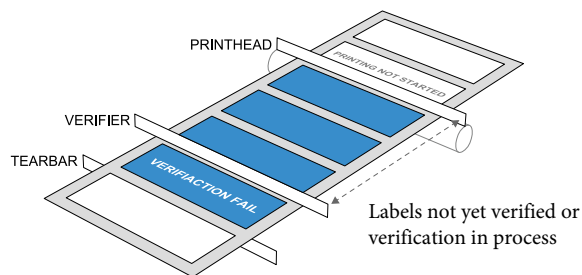

- All blue labels will be reprinted and verified after error recovery.
- All blue labels will be marked as **FAIL** in verification result database.

Scenario 2

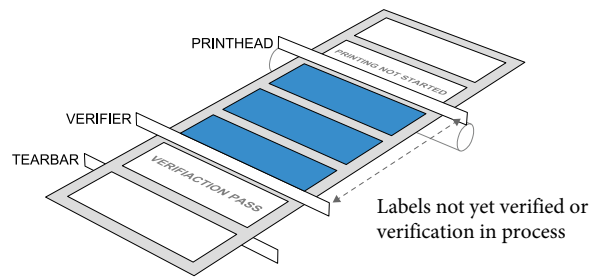

- All blue labels will be reprinted and verified after error recovery.
- All blue labels will be marked as **FAIL** in verification result database.

Scenario 3

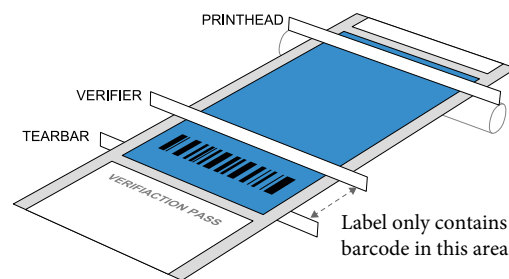

- Label verification in progress.
- This label will be marked **PASS** in verification result database.

Scenario 4

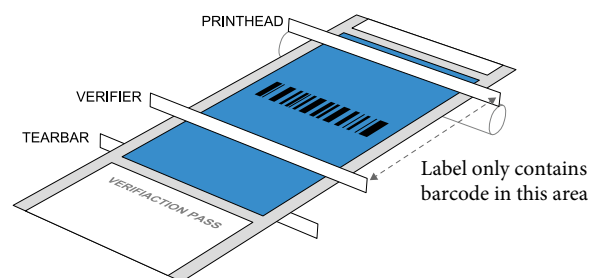

- Label verification in progress.
- This label will be marked **FAIL** in verification result database.

Unsupported Barcode Behavior

The printer will display an “Unsupported Barcode” warning message in all user interfaces (UI, webpage, SNMP, PrintSet, etc.) if there is an unsupported barcode type or unsupported barcode size in the label.

In the verification report, if all the supported barcodes in the label are PASS, then “Label Status” will display PASS and the printer will rely on the “Label Status” for verification failure handling.

If there an unsupported barcode exists in the label, there will be a status field to indicate the barcode is unsupported due to unsupported type or unsupported size.

Example:

Scenario 1: All barcodes printed on the label are unsupported or unsupported size

- Label Status = Pass
- Individual barcode status = Unsupported Barcode / Unsupported Size
- UI display “Unsupported Barcode” warning message

Scenario 2: At least one barcode printed on the label is supported

- Label Status = Pass/Fail (based on supported barcode)
- Individual barcode status = Pass/Fail/Unsupported Barcode/Unsupported Size
- UI display “Verification Fail” if label status is Fail, otherwise it will display “Unsupported Barcode”

Verify Unsupported Barcode

When this setting is enabled, the printer will void labels with unsupported barcodes and raise the verification failed dialog box immediately after the voiding.

Selective Barcode Verification

This allows the user to enable or disable particular barcode verification based on the following groupings:

No	Barcode Selection	Barcode Group
1	CODE39	Code 39 HIBC 39 LOGMARS
2	CODE128	Code 128 EAN 128 HIBC 128 UCC 128 ISBT 128 CODABLOCK (Single row)
3	EAN8	EAN 8
4	EAN13	EAN 13

No	Barcode Selection	Barcode Group
5	UPCA	UPC-A
6	UPCE	UPC-E
7	INT2OF5	Interleave 2 of 5, ITF-14
8	DATABAR	GS1 Databar Expanded / RSS14E
9	CODE93	Code 93
10	DATAMATRIX	Datamatrix ISBT Datamatrix
11	QRCODE	QR Code

The status in the verification report will displayed as **Barcode Disabled** if disabled.

Results displayed in webpage:

Result Information		
Barcode 1 : Unsupported Size		
Symbology CODE39	Size 4.9 mils	Data
Barcode 2 : Barcode Disabled		
Symbology CODE39	Size 9.9 mils	Data

Result displayed in XML report file:

```
<PassingGrade>1.5 (C)</PassingGrade>
<HardwareAperture>5.8 mils</HardwareAperture>
<Date>20201010</Date>
<Time>195802</Time>
<CalibrationDate>Expired</CalibrationDate>
<LabelGrade>0.0 (F)</LabelGrade>
<LabelStatus>Fail</LabelStatus>
<FailureReason>Barcode verification fail</FailureReason>
<Image>PX940V_1833324EC_2_20201010_195802.jpg</Image>
<Barcodes>8</Barcodes>
<Barcode ID="1">
  <Symbology>CODE39</Symbology>
  <Size>4.9 mils</Size>
  <Data></Data>
  <Status>Unsupported Size</Status>
  <XPos>291</XPos>
  <YPos>681</YPos>
  <Width>600 pixels</Width>
  <Height>213 pixels</Height>
</Barcode>
<Barcode ID="2">
  <Symbology>CODE39</Symbology>
  <Size>9.9 mils</Size>
  <Data></Data>
  <Status>Barcode Disabled</Status>
  <XPos>1325</XPos>
  <YPos>681</YPos>
  <Width>1056 pixels</Width>
  <Height>213 pixels</Height>
</Barcode>
```

Verification Failed Error Handling

When the print job's barcode has failed in the verification process, there are several ways to identify and fix the issue:

- Voiding the label and reprinting (default)
- No voiding and proceed with subsequent print jobs.

Note: In the Webpage menu, **Verification** > **Verifier Image**, you can access the last label image scan (if available)

Failed Label Image File

Summary	Description
Image Format	JPG
Maximum Files	100 files or flash memory is 75% full before the printer start to replace the oldest file in a round robin.
Path	/home/user/verifier/images
File name	<Printer Model Name>_<Printer Serial Number>_<LabelID>_YYYYMMDD_HHMMSS.jpg Example: PX940V_0000001234567_1_20181026_142800.jpg

The failed label image will not be generated if one of the following scenarios is true

- All supported barcodes in the label are meeting the passing grade or readability criteria.
- "Saved Failed Label Images" setting is disabled.

The failed label image file can be downloaded through the following method:

- USB Thumbdrive
- FTP/SFTP
- Webpage

USB Thumbdrive

1. Export all existing individual verification reports and failed label image files
 - Insert the USB thumb drive to the printer.
 - Go to **TOOLS** menu from the LCD to export all verification results.
 - Select **Remove USB** to safely remove the USB thumbdrive.

Note: *If images are saved on a thumbdrive, the limit is the thumbdrive capacity.*

2. Saving verification results in run-time
 - Create a directory in the root of USB thumbdrive named "verifier"
 - Insert the USB thumbdrive to the printer
 - The printer will start saving from the next verification XML report and failed label image if any to the USB thumbdrive.
 - Select **Remove USB** in USB menu in order to safely remove the USB thumbdrive.

Reporting and Statistics

In the **Webpage > Verification > Verification Results** you can see the list of the individual reports (if available).

You can also see the number of labels verified, failure rates, and print statistics.

Report Formats

Summary	Description
File Format	xml
File Name	Individual report: <Printer Model Name>_<Printer Serial Number>_<Label ID>_<YYYYMMDD>_<HHMMSS>.xml Example: PX940V_0000001234567_1_20181026_142800.xml Summary report: <Printer Model Name>_<Printer Serial Number>_<Start of Label ID>_<End of Label ID>.xml Example: PX940V_0000001234567_1_50.xml
Content	The various measured parameters for all verified barcodes found in the label

The failed label image and report (in XML format) will not be generated if one of the following scenarios is true.

- **Save Label Images** setting is disabled.
- All supported barcodes in the label are meeting the passing grade or readability criteria.
- Un-verified label/s due to certain condition e.g. printer error, abort action selected in Non-Sequential and Grading Override Disable, etc.

The example below shows the number of failed label image and report saved when the **Saved Label Images** setting is enabled.

- Initial print - FAIL (save the failed label image and report)
- First reprint - FAIL (save the failed label image and report)
- Second reprint - PASS

Total failed label image and report saved is 2.

Individual Report

For individual report, it saves the detailed information of the barcodes in the label. The content includes barcode type, size, encoded data, ANSI grade and the detailed parameter of ANSI grade. Each individual label report consists of 3 parts.

- Report header
- Barcode information
- Barcode grading parameter (not applicable for Read/No Read verification type)
- 1D Barcode 10 line profile grading parameter (not applicable for Read/No Read verification type)

Report Header

Content	Read/No Read	ISO 15415/15416	Description
Label ID	Yes	Yes	Unique counter for each printed label. Reset to 1 when user reset the verification user storage/database Example: <Label ID="1"> - First label verified after reset.
PrintJob ID	Yes	Yes	Unique counter for each print job. Reset to 1 when user reset the verification user storage/database Example: <PrintJobID>1<PrintJobID> - First print job after reset
Verification Type	Yes	Yes	Barcode verification type Example: <VerificationType>Read/No Read</VerificationType>
Passing Grade Threshold	No	Yes	Passing grade threshold - not applicable for the Read/No Read and GS1 application. GS1 will have an individual passing grade for each barcode type defined in the profile. Example: <PassingGrade>1.5 (C)</PassingGrade>
Hardware Aperture	Yes	Yes	Integrated verifier aperture size measured. Example: <hardwareAperture>4.4 mils</HardwareAperture>
Date	Yes	Yes	Date when the label is printed Format: YYYYMMDD Example: ,Date>20180320</Date>
Time	Yes	Yes	Time when the label is printed Format: HHMMSS Example: <Time>131120</Time>
Last Calibration Date	Yes	Yes	Last verifier calibration date "Expired" will be indicated if the last calibration date is past the duration determined by the design. Format: YYYYMMDD Example: <CalibrationDate>20180320</CalibrationDate> or <CalibrationDate>Expired</CalibrationDate>
Label Grade	No	Yes	Indicate the lowest grade of the barcode in the label Example: <LabelGrade>3.3 (B)</LabelGrade>
Label Status	Yes	Yes	Verification status for the label, Pass or Fail Example: <LabelStatus>Pass</LabelStatus>
Failure Reason	Yes	Yes	Reason for failed label. Example: <FailureReason>Barcode verification fail</FailureReason>
Image	Yes	Yes	Failed label image file name Example: <Image>PX940V 0000001234567 1 20180322 093000.jpg</Image>
Barcodes	Yes	Yes	A total number of barcodes in this label

Barcode Information

Content	Read/ No Read	ISO 15415/ 15416	Description
Barcode ID	Yes	Yes	Unique number for individual barcode in each label. Number start from 1. Example: <Barcode ID="1">
Symbology	Yes	Yes	Barcode type Example: <Symbology>CODE39</Symbology>
Version	No	Yes	Symbol version for QR Code, in the form of V-E where V identifies version number (1 to 40) and E indicates error correction level (L, M, Q, H). Example: <Version>7-L</Version>
Size	Yes	Yes	Barcode size Example: <Size>9.8 mils</Size>
Data	Yes	Yes	Decoded data. For Read / No Read, this field will leave empty if failed in either one of the passing criteria. Example: <Data>1234567890</Data>
Encoded Data	No	Yes	Encoded data. This field displays the data together with all encoded symbol characters for 1D barcode. Example: <EncodedData><Start>1234567890<Stop></EncodedData>
Grade	No	Yes	Grading results for this barcode Example: <Grade>3.3 (B)/5/660</Grade>
Status	Yes	Yes	Verification status for this barcode, Pass or Fail Example: <Status>Pass</Status>
Failure Reason	Yes	Yes	Reason for failed barcode. Example: <FailureReason>Contrast not uniform throughout barcode</FailureReason>
Scan Line Data Check	Yes	Yes	Scan line data consistency check status for 1D barcode. Status: <ul style="list-style-type: none"> • Pass - All 10 scan line data is same. • Fail - At least 1 of the scan line data mismatched with others. • NA - 2D barcode Example: <ScanLineDataCheck>Pass</ScanLineDataCheck>
X Position	Yes	Yes	Barcode X coordinate start position in pixel. Example: <XPos>100</XPos>
Y Position	Yes	Yes	Barcode Y coordinate start position in pixel. Example: <YPos>100</YPos>
Width	Yes	Yes	Barcode width in pixels Example: <Width>720 pixels</Width>
Height	Yes	Yes	Barcode height in pixels Example: <Height>480 pixels</Height>

Failure Reason Information

Barcode Types	Failed Grading Parameter	Failure Reason
ALL	-	Not able to read barcode
	-	Verified data not matching printed data
1D	Decode	Some scan lines failing to decode
	Quiet Zone	Some scan lines failing quiet zone
	Min Edge Contrast	At least one bar or space has poor contrast
	Modulation	Contrast not uniform throughout barcode
	Symbol Contrast	Poor contrast between bars and spaces
	Decodability	Poor decodability
	Defects	Large defect(s) detected
	R Min	Space element too dark
2D	Decode	Not able to decode barcode
	Unused Error Correction	Barcode damage causing error correction to be used
	Reflectance Margin	Poor contrast causing incorrect dark or light module
	Modulation	Contrast not uniform throughout barcode
	Symbol Contrast	Poor contrast between dark and light modules
	Fixed Pattern Damage	Damage to outer pattern of barcode
	Axial Non-uniformity	Uneven scaling in X and Y dimensions
	Grid Non-uniformity	Skewed or distorted barcode
QR Code	Format Information	Damage to format information blocks
	Version Information	Damage to version information blocks

Barcode Grading Parameters

The following section is not applicable to Read / No Read verification type.

Depending on the symbology type, 1D or 2D (Datamatrix and QR Code), one of the parameter tables below will be exported to the XML report.

1. All Supported 1D Barcodes Overall Parameters
2. 1D barcode 10 line Profile Grading Parameters
 - For 1D overall parameter, averaging for Decode and Quiet Zone is across all scan lines, whereas averaging for the rest is across only decodable scan lines.
3. 2D Barcode, DataMatrix Overall Parameters
 - For 2D overall parameter, Datamatrix specific parameters are L1, L2, QZL1, QZL2, OCTASA and AG. QR Code specific parameters are A1, A2, A3, B1, B2, C, Format Information and Version Information.

All Supported 1D Barcodes Overall Parameters

Content	Description
R Max	The highest reflectance in any element or quiet zone in a scan reflectance profile, or the highest reflectance of any sample area in a two-dimensional matrix symbol. Example: <RMax>79.2%</RMax>
R Min	The lowest reflectance in any element in a scan reflectance profile, or the lowest reflectance of any sample area in a two-dimensional matrix symbol. Example: <RMin Grade="4.0">0.5%</RMin>
Min Edge Contrast	The minimum difference between bar reflectance and space reflectance of two adjacent elements. Example: <ECMin Grade="4.0">67.2%</ECMin>
Symbol Contrast	The difference between the highest and lowest reflectance values in a scan reflectance profile. Example: <SymbolContrast Grade="4.0">84.0%</SymbolContrast>
Modulation	The ratio of minimum contrast to symbol contrast. Example: <Modulation Grade="4.0">80.0%</Modulation>
Defects	Irregularities found within elements and quiet zones; measured in terms of element reflectance non-uniformity. Example: <Defects Grade="4.0">8.5%</Defects>
Decodability	A measure of the accuracy of its production in relation to the appropriate reference decode algorithm. Example: <Decodability Grade="4.0">76.5%</Decodability>
Decode	Decodable symbols shall comply with the symbology specification. Value in grade. Example: <Decode Grade="4.0"/>
Quiet Zone	The areas to the left and right of the barcode that is free from text or graphics to successfully read the barcode. Example: <QuietZone Grade="4.0"/>
Global Threshold	The reflectance level midway between the maximum and minimum reflectance values in a scan reflectance profile, used for the initial identification of elements. Example: <GlobalThreshold>42.5%</GlobalThreshold>
Print Contrast Signal	The contrast between bars and spaces or background. Example: <PCS>99.4%</PCS>
Average Bar Gain	Average bar gain or loss in percentage Example: <BarGain>-1.1%</BarGain>

2D Barcode, DataMatrix Overall Parameters

Content	Description
R Max	The highest reflectance in any element or quiet zone in a scan reflectance profile, or the highest reflectance of any sample area in a two-dimensional matrix symbol. Example: <RMax>86.6%</RMax>
R Min	The lowest reflectance in any element in a scan reflectance profile, or the lowest reflectance of any sample are in a two-dimensional matrix symbol. Example: <RMin>16.8%</RMin>
Symbol Contrast	The difference between the highest and lowest reflectance values in a scan reflectance profile. Example: <SymbolContrast Grade="4.0">69.8%</SymbolContrast>
Modulation	A measure of the uniformity of reflectance of the dark and light modules, respectively. Example: <Modulation Grade="4.0"/>
Reflectance Margin Grade	A measure of how well each element of the symbol is correctly distinguishable as light or dark in comparison to the global threshold.
Decode	Decodable symbols shall comply with the symbology specification. Value in grade Example: <Decode Grade="4.0"/>
Axial Nonuniformity	Measures the grades and spacing of the mapping centers (sampling points) or intersections of the grid and tests for uneven scaling of the symbol. Example: <AxialNonuniformity Grade="4.0">1.9%</AxialNonuniformity>
Grid Nonuniformity	Measures and grades the largest vector deviation of the grid intersections. Example: <GridNonuniformity Grade="4.0">5.4%</GridNonuniformity>
Unused Error Correction	Tests the extent to which regional or spot damage in the symbol has eroded the reading safety margin that error correction provides. Example: <UnusedEC Grade="4.0">100.0%</UnusedEC>
Fixed Pattern Damage	Tests the damage to the finder pattern, quiet zone timing, navigation, and other fixed patterns. Example: <FixedPatternDamage Grade="4.0"/>
L1 (left of L finder)	L1 in grade Example: <L1 Grade="4.0"/>
L2 (bottom of L finder)	L2 in grade Example: <L1 Grade="4.0"/>
QZL1 (left quiet zone)	QZL1 in grade Example: <QZL1 Grade="4.0"/>
QZL2 (bottom quiet zone)	QZL2 in grade Example: <QZL2 Grade="4.0"/>
OCTASA (overall clock track and solid area)	OCTASA in grade Example: <OCTASA Grade="4.0"/>

Content	Description
AG (average grade)	AG in grade Example: <AG Grade="4.0"/>
Contrast Uniformity	The minimum MOD value found in any module contained in the data region of the symbol and does not affect the overall grade. Example: <ContrastUniformity>52.8%</ContrastUniformity>
Print Growth X	Print growth X in percentage Example: <PrintGrowthX>9.3%</PrintGrowthX>
Print Growth Y	Print growth Y in percentage Example: <PrintGrowthY>9.3%</PrintGrowthY>
MatrixSize	Symbol size specified in Row x Column Example: <MatrixSize>16x16</MatrixSize>

2D Barcode, QR Barcode Overall Parameters

Content	Description
R Max	The highest reflectance in any element or quiet zone in a scan reflectance profile, or the highest reflectance of any sample area in a two-dimensional matrix symbol. Example: <RMax>86.6%</RMax>
R Min	The lowest reflectance in any element in a scan reflectance profile, or the lowest reflectance of any sample are in a two-dimensional matrix symbol. Example: <RMin>16.8%</RMin>
Symbol Contrast	The difference between the highest and lowest reflectance values in a scan reflectance profile. Example: <SymbolContrast Grade="4.0">69.8%</SymbolContrast>
Modulation	A measure of the uniformity of reflectance of the dark and light modules, respectively. Example: <Modulation Grade="4.0"/>
Reflectance Margin Grade	A measure of how well each element of the symbol is correctly distinguishable as light or dark in comparison to the global threshold.
Decode	Decodable symbols shall comply with the symbology specification. Value in grade Example: <Decode Grade="4.0"/>
Axial Nonuniformity	Measures the grades and spacing of the mapping centers (sampling points) or intersections of the grid and tests for uneven scaling of the symbol. Example: <AxialNonuniformity Grade="4.0">1.9%</AxialNonuniformity>
Grid Nonuniformity	Measures and grades the largest vector deviation of the grid intersections. Example: <GridNonuniformity Grade="4.0">5.4%</GridNonuniformity>

Content	Description
Unused Error Correction	Tests the extent to which regional or spot damage in the symbol has eroded the reading safety margin that error correction provides. Example: <UnusedEC Grade="4.0">100.0%</UnusedEC>
Fixed Pattern Damage	Tests the damage to the finder pattern, quiet zone timing, navigation, and other fixed patterns. Example: <FixedPatternDamage Grade="4.0"/>
A1 segment	A1 in grade Example: <A1 Grade="4.0"/>
A2 segment	A2 in grade Example: <A2 Grade="4.0"/>
A3 segment	A3 in grade Example: <A3 Grade="4.0"/>
B1 segment	B1 in grade Example: <B1 Grade="4.0"/>
B2 segment	B2 in grade Example: <B2 Grade="4.0"/>
C segment	C in grade Example: <C Grade="4.0"/>
Format Information	Format information in grade Example: <FormatInfo Grade="4.0"/>
Version Information	Version information in grade Example: <VersionInfo Grade="4.0"/>
Contrast Uniformity	The minimum MOD value found in any module contained in the data region of the symbol and does not affect the overall grade. Example: <ContrastUniformity>52.8%</ContrastUniformity>
Print Growth X	Print growth X in percentage Example: <PrintGrowthX>9.3%</PrintGrowthX>
Print Growth Y	Print growth Y in percentage Example: <PrintGrowthY>9.3%</PrintGrowthY>
MatrixSize	Symbol size specified in Row x Column Example: <MatrixSize>16x16</MatrixSize>

1D barcode 10 line Profile Grading Parameters

Content	Description
Line ID	Scan line number for individual barcode. Number start from 1. Example: <Line ID="1">
Grade	Grading results for this barcode line Example: <Grade>3.3</Grade>
R Max	The highest reflectance in any element or quiet zone in a scan reflectance profile, or the highest reflectance of any sample area in a two-dimensional matrix symbol. Example: <RMax>79%</rMax>
R Min	The lowest reflectance in any element in a scan reflectance profile, or the lowest reflectance of any sample are in a two-dimensional matrix symbol. Example: <RMin Grade="4.0">0.2%</RMin>
Min Edge Contrast	The minimum difference between bar reflectance and space reflectance of two adjacent elements. Example: <ECMin Grade="4.0">68.4%</ECMin>
Symbol Contrast	The difference between the highest and lowest reflectance values in a scan reflectance profile. Example: <SymbolContrast Grade="4.0">83.3%</SymbolContrast>
Modulation	The ratio of minimum edge contrast to symbol contrast. Example: <Modulation Grade="4.0">82.2%</Modulation>
Defects	Irregularities found within elements and quiet zones; measured in terms of element reflectance. Example: <Defects Grade="4.0">6.2%</Defects>
Decodability	A measure of the accuracy of its production in relation to the appropriate reference decode algorithm. Example: <Decodability Grade="4.0">75.5%</Decodability>
Decode	Decodable symbols shall comply with the symbology specification. Value in grade. Example: <Decode Grade="4.0"/>
Quiet Zone	Quiet Zone. Value in grade. Example: <QuietZone Grade="4.0"/>
Global Threshold	The reflectance level midway between the maximum and minimum reflectance values in a scan reflectance profile used for the initial identification of elements. Example: <GlobalThreshold>41.0%</GlobalThreshold>
Print Contrast Signal	Print Contrast Signal (PCS) in percentage Example: <PCS>97.0%</PCS>
Average Bar Gain	Average bar gain in percentage Example: <BarGain>3.0%</BarGain>

Restore Default Verification Files

You can restore the default verification database and remove all failed label image files in order to free up the memory through the following interfaces:

- PrintSet 5
- Web page
- LCD

To restore the default verification database:

1. Go to **Webpage > Services > Restore Defaults > Verification Files**
2. Click **Restore**

Fingerprint Command

To show verification results/record summary on standard I/O or label after the last verification database been reset.

VERIFIER RESULT [PRINT]

Argument	Description
PRINT	To print the summary on the label

Send this command to retrieve summary of verification results. A typical result might be:

- Verified: 104 labels
- Failed: 3 labels
- Failure Rate: 2.9%

To get the summary printed on the label:

VERIFIER > RESULT > PRINT

This Fingerprint command reads system array or setting system variables for Verifier status retrieving.

Syntax: SYSVAR(<nexp>)

Parameter	Description
<nexp>	Reference number of the system variable as described in the next table.

No.	Description	Notes
105	Read Label Verification Status	Read the label verification status 0 = Label verification not completed 1 = Label verification completed
106	Read Label Verification Result	Read label verification result 0 = Label verification pass Non-Zero = Label verification failed, and error code is returned.

About Barcode Template

Barcode template is a xml file consist of barcode information use to decode barcode in verifier. There are three type of barcode templates: Graphic Barcode, Barcode Specific and Generic Rule. User can pre-set the xml template verification.xml by defining new verification rules. Upon verifier initialization, the xml template verification.xml will be loaded from /system/home/user/verifier/templates to verifier and ready to verify next job.

Note: User should restart the printer in order to refresh template if user wish to replace new verification.xml in /system/home/user/verifier/templates/

Graphic Barcode

In Graphic Barcode Mode (GB Mode), a xml template consist pre-set Graphic Barcode information will be used to decode the graphic barcode in verifier. See below diagram for format of Graphic Barcode template.

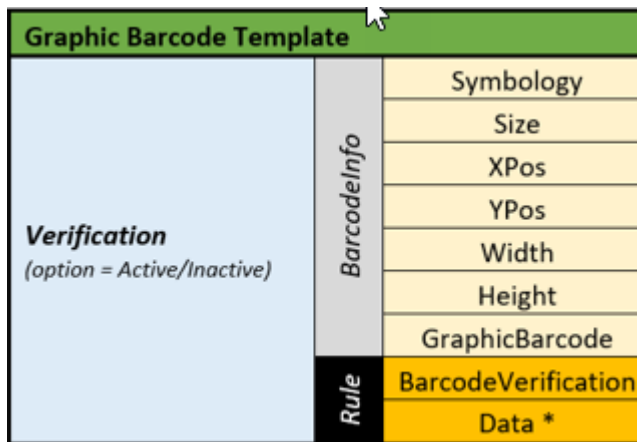

Note: Data is not mandatory field. Data checking will be skipped if Data is empty or Data field doesn't exist in template.

You can insert multiple Verifications in the template based on the total number of Graphic Barcodes that need to be verified in the label.

To enable Graphic Barcode decoding, set Verification option to **Active** and **GraphicBarcode** to **Yes**, then set **BarcodeVerification** to **Enable**. Next, fill in the following mandatory fields in **BarcodeInfo**:

- Symbology
- Size
- XPos
- YPos
- Width
- Height

If Verification option is set to **Inactive**, current Verification will be skipped or ignored.

If mandatory parameters in **BarcodeInfo** are incomplete, current Verification will be skipped or ignored.

Example for Graphic Barcode Template:

```
<?xml version="1.0" encoding="UTF-8"?>
- <VerificationXML>
  <!-- Template for graphic barcode decoding -->
  <!-- 1st verification, decode Graphic Barcode, CODE39, data=12345678, size 13.6mils-->
  <!-- at position x300,y445,w155,h599, Data Checking -->
  - <Verification option="Active">
    - <BarcodeInfo>
      <Symbology>CODE39</Symbology>
      <Size>13.6</Size>
      <XPos>300</XPos>
      <YPos>445</YPos>
      <Width>155</Width>
      <Height>599</Height>
      <GraphicBarcode>Yes</GraphicBarcode>
    </BarcodeInfo>
    - <Rule>
      <BarcodeVerification>Enable</BarcodeVerification>
      <Data>12345678</Data>
    </Rule>
  </Verification>
  <!-- 2nd verification, decode Graphic Barcode, CODE128, size 10.1mils-->
  <!-- at position x500,y1600,w768,h611, No Data Checking -->
  - <Verification option="Active">
    - <BarcodeInfo>
      <Symbology>CODE128</Symbology>
      <Size>10.1</Size>
      <XPos>500</XPos>
      <YPos>1600</YPos>
      <Width>768</Width>
      <Height>611</Height>
      <GraphicBarcode>Yes</GraphicBarcode>
    </BarcodeInfo>
    - <Rule>
      <BarcodeVerification>Enable</BarcodeVerification>
    </Rule>
  </Verification>
  <!-- 3rd verification, Inactive option, this rule will be ignored -->
  - <Verification option="Inactive">
    - <BarcodeInfo>
      <Symbology>CODE93</Symbology>
      <Size>13.6</Size>
      <XPos>400</XPos>
      <YPos>605</YPos>
      <Width>300</Width>
      <Height>290</Height>
      <GraphicBarcode>Yes</GraphicBarcode>
    </BarcodeInfo>
    - <Rule>
      <BarcodeVerification>Enable</BarcodeVerification>
      <Data>12345678</Data>
    </Rule>
  </Verification>
</VerificationXML>
```

Refer to template above, first and second Verification set to **Active** option, therefore barcode with specified symbology, size at specified position will be verified by verifier.

For third Verification, the option set to **Inactive**, current verification will be skipped.

To set the barcode position in template, you can measure the physical label printout to determine the barcode cropping zone. Measurement is in 600dpi scan resolution.

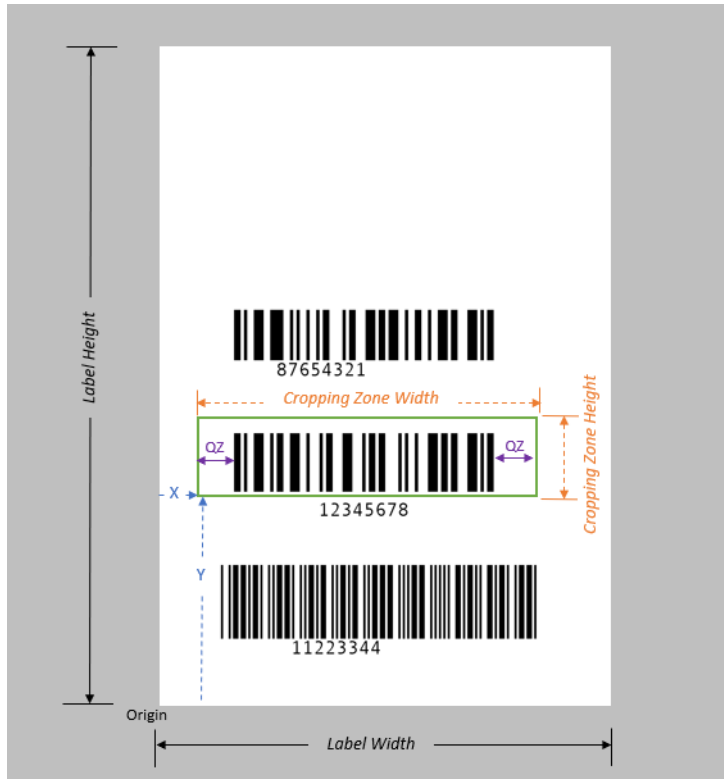

See label above, second barcode is a graphic barcode. The X and Y position from origin are the XPos and YPos or graphic barcode in template.

User should include the QuietZone (QZ) as much as possible at barcode left and right, if the cropping zone doesn't overlap with another barcode cropping zone.

The measurement of second graphic barcode shown in table below:

	Measurement in inches	Measurement in Dots (Inch x 600)
X (XPos)	0.39	234
Y (YPos)	1.89	1134
Cropping Zone Width (Width)	3.15	1890
Cropping Zone Height (Height)	0.79	474

Lastly, fill the template with the measurement results in 600dpi

```

- <Verification option="Active">
  - <BarcodeInfo>
    <Symbology>CODE128C</Symbology>
    <Size>30.1</Size>
    <XPos>234</XPos>
    <YPos>1134</YPos>
    <Width>1890</Width>
    <Height>474</Height>
    <GraphicBarcode>Yes</GraphicBarcode>
  </BarcodeInfo>
  - <Rule>
    <BarcodeVerification>Enable</BarcodeVerification>
  </Rule>
</Verification>

```

Parameters

Parameters for barcode template.

Verification

Property	Value
Description	This field is to enable/disable the Verification in templates. If set to Active , current Verification will be activated. Current Verification will be ignored if user inputs invalid attribute value or set to Inactive
Value	Active Inactive
Default	Inactive
Mandatory Field	Yes
Example	<VerificationRule option=" Active ">

Barcode Verification

Property	Value
Description	This field is to enable/disable Symbology specified in barcode information in current Verification. If user inputs invalid value for BarcodeVerification or this field doesn't exist in template, default value will be used.
Value	Enable Disable
Default	Enable
Mandatory Field	Yes
Example	<BarcodeVerification>Enable</BarcodeVerification>

Symbology

Property	Value
Description	Barcode Symbology
Value	CODE39 CODE93 CODE128 DATABAR DATAMATRIX EAN8 EAN13 UPCA UPCE INT2OF5 QRCODE
Default	None
Mandatory Field	No (Except Graphic Barcode Mode)
Example	<Symbology>CODE39</Symbology>

Size

Property	Value
Description	Barcode X-dimension/ Mil size
Value	0.0 - 100.0
Default	None
Mandatory Field	No (Except Graphic Barcode Mode)
Unit	Mils, with one decimal point
Example	<Size>13.6 </Size>

XPos

Property	Value
Description	Start position in X-axis (horizontal) of current barcode cropping zone. User Should input correct XPos in template to find the correct horizontal start position of barcode. XPos value is based on scan resolution 600dpi.
Value	0 - Printable Label Width
Default	None
Mandatory Field	Yes (Except Graphic Barcode Mode)
Unit	Pixels
Example	<XPos>500</XPos>

YPos

Property	Value
Description	Start position in Y-axis (vertical) of current barcode cropping zone. User Should input correct YPos in template to find the correct vertical start position of barcode. YPos value is based on scan resolution 600dpi.
Value	0 - Printable Label Length
Default	None
Mandatory Field	Yes (Except Graphic Barcode Mode)
Unit	Pixels
Example	<YPos>500</YPos>

Width

Property	Value
Description	Width of current barcode cropping zone.
Value	0 - Printable Label Width
Default	None
Mandatory Field	Yes (Except Graphic Barcode Mode)
Unit	Pixels
Example	<Width>1553</Width>

Height

Property	Value
Description	Height of current barcode cropping zone.
Value	0 - Printable Label Height
Default	None
Mandatory Field	Yes (Except Graphic Barcode Mode)
Unit	Pixels
Example	<Height>599</Height>

Graphic Barcode

Property	Value
Description	To activate Graphic Barcode mode in Verification, this field should set to Yes. If this field is empty or doesn't exist in template, default value will be used.
Value	Yes No
Default	No
Mandatory Field	Yes for Graphic Barcode Mode only
Example	<GraphicBarcode>Yes</GraphicBarcode>

Data

Property	Value
Description	Input Data to barcode. It is optional to input Data to current barcode. Data checking will be performed if data exist. For non-readable characters, the input format is like [X], where X is hex value between ASCII 0x00 to 0x1F and 0x80 to 0xFF. Data checking will be disabled if Data field doesn't exist in template or data length is zero.
Default	No
Mandatory Field	No
Example	<Data>12345678</Data> or <Data> [1F]12345[03]78</Data>

Fingerprint Application Support

When running a Fingerprint application, the program needs to handle all the printer errors and verification error by itself. The program should handle voiding and reprinting after recovering from the error. Therefore, the verification failure action setting needs to be configured as **Ignore and Continue** to prevent the printer system from starting voiding and reprinting automatically.

About Data Reporting

There are multiple ways to export data from the PX940, either manually or automatically.

The table below shows the various interfaces and their capabilities.

Report	Web Page	FTP Push	USB Drive	Verifier Integration Interface (VII)
XML Report (Individual)	Yes	Yes	Yes	Yes
CSV Report (Multiple)	Yes	Yes	No	No
Last Image	Yes	No	No	Yes
Failed Images	Yes	No	Yes	No
High Level Statistics	Yes	No	No	No

Verification Report Level

Report levels and details can be configured in **Verification Settings > Verification > Report Level**.

Note: When the report level setting is changed, the existing database will reset and delete all old reports, to ensure maximum performance.

There are five report levels:

Report Level	Label Info and Grade	Barcode Info and Grade	Barcode ISO Parameters	10 Line Data (1D)
1	No	No	No	No
2	Yes	No	No	No
3	Yes	Yes	No	No
4 (default)	Yes	Yes	Yes	No
5	Yes	Yes	Yes	Yes

Note: If you are using the verifier in **Read/No Read mode**, the maximum level available is report Level 3. If configured to Level 4 or 5, it will fall back to Level 3.

Verification Report Format

The PX940 printer provides two main formats for reporting verification results. For both types, the level of details is based on the Report Level setting.

1. XML: a report for each individual label, ideal for frequent exporting.
 - Supports Levels 2, 3, 4, and 5
 - Can be exported from web page, FTP/SFTP, and USB
 - Easy to read
 - Ideal for troubleshooting as it is the only format that supports Level 5 reporting.

2. CSV: an overview of multiple results, consolidated into a report for all of the results currently stored in the printer verification database.
 - Supports Levels 2, 3, and 4
 - Best viewed in Excel
 - Requires less space than XML
 - Great for creating trend graphs on overall grade or individual parameters, creating statistics to track printer behavior, quality, and issues in production.

Web Page Reporting

You can conduct reporting from the printer web page.

1. Web Page Export
 - From web page the export of data is always manual and require manual delete
 - CSV (summary) support level 2-4
 - XML (individual) supports level 2-5
2. Last Report
 - Last individual report is stored in `http://<printer IP>/tmp/last_saved_report.xml`
 - Last individual scan image is stored in `http://<printer IP>/tmp/last_saved_image.bmp`
 - Last individual scan image can be viewed in web page: Verification -> Verifier Image
3. Failed Images (only if option is enabled)
 - All failed images and reports from database are stored in `/home/user/verifier/images`
 - If thumb drive is inserted with `/verifier/` folder then nothing will be stored in `/home/user/`
4. Statistics
 - Report the number of passed and failed labels currently in database (non-accumulative)

Web Page Result Overview

Download all reports from database in one CSV file; filter is ignored

Delete all reports from database; filter is ignored

Apply filter for viewing in web page only

Result for individual label as well as clickable link to individual detailed report

Label ID	Time	Status
357	08/27/2019 15:48	Pass_3.9 (A)
356	08/27/2019 15:48	Pass_3.6 (A)
355	08/27/2019 15:48	Pass_3.9 (A)
354	08/27/2019 15:48	Pass_3.9 (A)
353	08/27/2019 15:48	Pass_3.9 (A)

Web Page Result – Individual Report

Download report in XML format

Label information

Individual barcode information

Report			
Verification Type	300 15415 15414		
Label Status	Pass		
Label Grade	3.9 (A)		
Passing Grade Threshold	1.5 (C)		
Date & Time	2019/07/11 06:54:03		
Last Calibration	2019/06/21		

Result Information			
Barcode 1 (Pass)			
Verification Type	300 15415 15414	Date	2019/07/11 06:54:03
Grade	3.9 (A)	Passing Grade	1.5 (C)
Label Status	Pass	Barcode	300 15415 15414
Label Grade	3.9 (A)	Barcode	300 15415 15414
Passing Grade Threshold	1.5 (C)	Barcode	300 15415 15414
Date & Time	2019/07/11 06:54:03	Barcode	300 15415 15414
Last Calibration	2019/06/21	Barcode	300 15415 15414

About FTP/SFTP Push

You can configure the printer to automatically push XML/CSV reports to an external FTP/SFTP server. You can configure and transfer the interval once the report has been transferred to the server, it will be deleted from the database.

Note: To transfer data to a specific folder on the server, it has to be configured through the FTP/SFTP server settings. The printer does not support selecting a specific folder.

To enable the FTP/SFTP feature on the web page, you have to input the FTP/SFTP server IP address, FTP/SFTP user name and password, the interval to transfer reports, and report format (XML or CSV)

Note: To disable the FTP/SFTP feature, set the IP address to 0.0.0.0

About USB Reporting

There are two methods to conduct USB reporting:

1. Automatic export

- To enable automatic reporting to a folder, “/verifier/” must be present in the thumb drive
- Report are in XML format, Report Level 2-5
- All passed or/and failed images and XML reports in database, stored in /verifier/ when ‘Save Label Images’ is enabled and ‘Export To USB’ is enabled
- If USB inserted, nothing will store in /home/user/verifier/images and failed images won't be displayed on webpage

Note: The automatic exporting of reports does not delete data from the database. No scanned images will be stored in /verifier/ when **Save Label Image** is disabled or **Export to USB** is disabled.

2. Manual export

- Access from USB menu in LCD
- Printer will create folder /verifier/ in the thumb drive and export all files to there
- Reports are in XML format, Report Level 2-5
- All failed images in /home/user/verifier/images will be exported as well
- You must manually delete results after exporting (e.g. restore defaults, selecting ‘Verification Files’ only)

About Save Label Images

Scanned label images and failed XML reports will be saved in non-volatile memory, **/home/user/verifier/images directory**. A maximum of 100 images and XML reports can be saved (if memory available).

Note: *At the maximum capacity, the oldest image and XML report file will be replaced by the newest.*

The tables below show details of how files are saved and in what location based on different combinations of settings and with USB thumbdrive inserted and a **verifier** folder on the drive.

No USB thumbdrive inserted, **Export to USB** disabled, files saved in file system:

Save Label Images Option	Images Saved	XML Saved
Disable	None	Nine
Failed Labels Only	Failed Labels	Failed Labels
All Labels	All Labels	None

USB thumbdrive inserted, **Export to USB** disabled, files saved in file system:

Save Label Images Option	Images Saved	XML Saved
Disable	None	Nine
Failed Labels Only	Failed Labels	Failed Labels
All Labels	All Labels	None

USB thumbdrive inserted, Export to USB enabled, saved in USB thumbdrive:

Save Label Images Option	Images Saved	XML Saved
Disable	None	Nine
Failed Labels Only	Failed Labels	All Labels
All Labels	All Labels	All Labels

About LCD Reporting

LCD Reporting – During Verification

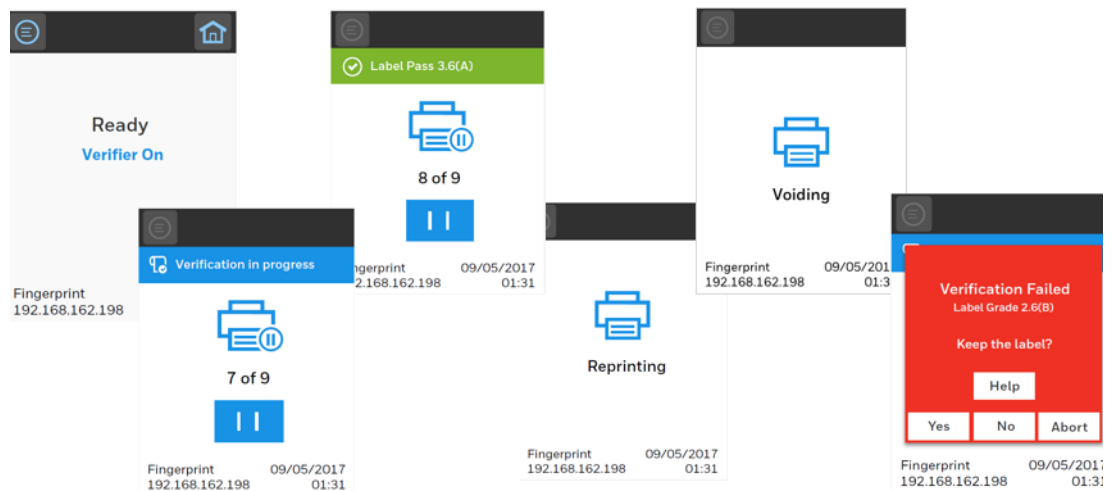

LCD Reporting-Barcode Result

LCD Reporting provides a high level of information for each barcode when the Report Level is set to Level 3 or higher.

To view the LCD Reporting - Barcode Result, go to **Tools > Results**.

System Information

Look in the **System Information** tab on the printer web page for useful information and statistics on the printer hardware and firmware.

Statistics

Use the printer web page to view important statistics about your printer.

Statistic Type	Information Available
System Information	Printer uptime and CPU usage, firmware and kernel versions, printer configuration and serial numbers, flash and RAM memory information
Supply	Printhead and ribbon information
Hardware Options	Input/output devices, serial port information
Network Interfaces	MAC address, TCP/IP, Bluetooth LE, and 802.11 network information
Font Information	Name, type, location, and size of installed fonts
Barcode Information	Name and type of installed barcode fonts
Image Information	Name, type, location, and size of installed images

1. Open a web browser on your PC.
2. In the address bar, type the IP address of your printer and press **Enter**. The printer web page appears.
3. Click the **System Information** tab.
4. Click **Statistics > System Information**. The System Information page appears.
5. For more detailed statistics, click another choice in the Statistics list.

Printer Odometer

You can check the odometer from the printer web page to see the printhead usage and how the current values compare to the alert values.

Note: *To check the printer odometer from the web page, the printer must be turned on and connected to your network.*

1. Open a web browser on your PC.
2. In the address bar, type the IP address of your printer and press **Enter**. The printer home page appears.
3. Click the **System Information** tab.
4. Select **Odometer**. The list of current odometer statistics appears.

Maintenance Alerts

To help maintain the printer, you can configure the printer to send alert messages when certain conditions occur. For example, the printer can send a message when the odometer reaches a certain value, or if the printhead is lifted during printing.

There are three types of alerts:

- Error alerts
- Information alerts
- Warning alerts

You configure alert settings in the printer web page. Alert messages can be sent to an email address, an SNMP trap, or both. You can enable or disable each type of alert, set the number of times the alert is repeated, set the unit of measure that determines how often the alert is sent, and change the default text message for the alert.

Set Alerts

You can set maintenance alerts to determine the threshold or value at which an alert is sent to you

1. Open a web browser on your PC.
2. In the address bar, type the IP address of your printer and press **Enter**. The printer web page appears.
3. Click **Login**. The Login page appears.
4. Type your Username and Password and then click Login. The default value for Username is **itadmin** and the default value for Password is **pass**.
5. Click the **Configure** tab. The Configuration Summary page appears.

6. Click **System Settings > Maintenance Alerts**. The Maintenance Alerts settings page appears.
7. Type the values you want to set for each maintenance alert.
8. Click **Save** when you are finished.

Alert Notifications

The way you receive error alerts is determined by the notification method you configure. You can choose between receiving notifications by SNMP trap, email, or SNMP trap + email.

- From the printer Main Menu, select **Settings > System Settings > General > Alert Notification Method**.

Or

- From the printer web page, login and then click the **Configure tab > System Settings > General > Alert Notification Method**.

Error Alerts and Solutions

Use these tables to understand and troubleshoot some common error alerts you may receive and how to fix them.

Error Alert	Solution
Label Not Taken	Printing has been stopped because a label is obstructing the label taken sensor. Remove the label to resume printing or try LTS sensor calibration to clear this error.
Printhead Lifted	Lower the printhead.
Front Arm Lifted	Lower Front Arm
Out of Ribbon	Load ribbon in the printer.
Out of Media	Load media in the printer.
Ribbon Low	The diameter of the remaining roll of media is lower than the specified value in the Ribbon Low Diameter setting. Replace the ribbon.
Media Low	The diameter of the remaining roll of media is lower than the specified value in the Media Low Diameter setting. Replace the media.
Ribbon Installed	The printer is configured as a direct thermal printer and thermal transfer ribbon is installed. Remove the ribbon or configure the printer for thermal transfer media.
Printer in Pause Mode	A print job is paused from the front panel. Press the Print button to resume printing.
Printer in Menu Mode	A user entered a menu from the front panel. Press the Home button to return to the Ready screen.
Application Break	Fingerprint only. An application breaks uncontrolled.
Print Job Complete	A print job has been successfully completed.

Error Alert	Solution
Odometer (Printer)	The printer has reached a limit set in the Odometer (Printer) setting in Maintenance Alerts for the amount of media to print before being alerted.
Odometer (Printhead)	The printhead has reached a limit set in the Odometer (Printhead) setting in Maintenance Alerts for the amount of media to print before being alerted.
Odometer (User Resettable)	The printer has reached a limit set in the Odometer (User Resettable) setting in Maintenance Alerts for the amount of media printed since the last reset.
Printhead Too Hot	The printhead is overheated and needs to cool down. Wait for printing to resume automatically.
Printhead Not Detected	The printer is not detecting the printhead. Check to make sure the printhead is installed and that the printhead cable is firmly connected to the printhead.
Faulty Dot	The printhead has reached the number of faulty dots set in the Faulty Dots setting in Maintenance Alerts. You may need to replace the printhead.
Replace Printhead	The printer has reached a limit set in the Replace Printhead setting in Maintenance Alerts for the amount of media to print before replacing the printhead. Replace the printhead.
Clean Printhead	The printer has reached a limit set in the Clean Printhead setting in Maintenance Alerts for the amount of media to print before cleaning the printhead. Clean the printhead.
Upgrading Firmware	The printer is going to start upgrading the firmware. Do not try to send anything to the printer.
Printer is Rebooting	The printer is going to restart. Wait until the printer is ready before attempting to communicate with it.
Started	The printer is in the process of starting up.

Verifier Error Alerts and Solutions

Error Alert	Solution
Verifier is Disabled	Set the Verifier Settings to READ/NO READ or ISO 15415/15416
Calibration Fail (clean) Calibration Fail (barcode)	Clean the verifier glass. Make sure that the calibration card is aligned correctly to the tear bar. Check the condition of the calibration card.
Front Arm Lifted	Lower Front Arm
Verification Failed	Check the quality of the printed label Clean the verifier glass Calibrate the verifier
Verifier Calibration Required	Calibrate the Verifier using the calibration card
Verifier Hardware Error	Contact support at www.support.honeywell.aidc.com
Unsupported Barcode	No impact on the label verification status. The unsupported barcode will be ignored
Verifier Calibration Recommended	Recalibrate the verifier to make sure the ANSI grading conforms to the standard.
Feed Card Error	Check whether the calibration card is feeding out correctly.

Error Alert	Solution
Calibration Fail (tone)	Replace the calibration card
Calibration Fail (aperture)	Contact support at www.support.honeywell.aidc.com
Calibration Fail (LED)	Check the condition of the calibration card. Align the calibration card with the tear bar. If the problem persists, contact support at www.support.honeywell.aidc.com

Troubleshoot Printer Problems and Find Solutions

Use this section to find possible solutions to printer problems.

Print Problems

Problem	Possible Solution
The printout is weak	Try these possible solutions in order: <ul style="list-style-type: none"> • Make sure that your media > print quality setting is appropriate for the type of media you are using. • The contrast may be too low. Increase the contrast. • The printhead pressure may be too low. Increase the printhead pressure. • Replace the printhead.
The printout is weaker on one side	Adjust the printhead balance.
There are weak spots on the printout.	Try these possible solutions in order: <ul style="list-style-type: none"> • There may be foreign particles on the media. Clean or replace the media. • Make sure that your media and ribbon are compatible. • Make sure that you are using high quality media and ribbon. • The contrast may be too low. Increase the contrast.
The printout is dark or there is excessive bleeding on the media	Try these possible solutions in order: <ul style="list-style-type: none"> • Make sure your media > print quality setting is appropriate for the type of media you are using. • The contrast may be too high. Decrease the contrast. • The printhead pressure may be too high. Decrease the printhead pressure.
There are dark lines along the media path	The printhead may be dirty. Clean the printhead.
There are white vertical lines on the printout	Try these possible solutions in order: <ul style="list-style-type: none"> • The printhead may be dirty. Clean the printhead. • There may be missing dots on the printhead. Replace the printhead.
Part of a dotted line is missing	Try these possible solutions in order: <ul style="list-style-type: none"> • The printhead may be failing. Replace the printhead.

Problem	Possible Solution
The inner edge of the printout is missing	Try these possible solutions in order: <ul style="list-style-type: none"> • The media may not be properly installed or aligned. Reload the media. • The media margin or X-start parameter may be set too low. Increase the setting.
The content on the printout is compressed	The print speed may be too high. Lower the print speed or adjust the printhead pressure.
Nothing shows up on the thermal transfer printout.	The ink-coated side of the ribbon may not be facing the media. Reload the ribbon.
The ribbon breaks	Try these possible solutions in order: <ul style="list-style-type: none"> • Make sure your media setting is appropriate for the type of media you are using. • Make sure that the ribbon is fitted correctly. Reload the ribbon.
The ribbon wrinkles	Try these possible solutions in order: <ul style="list-style-type: none"> • It is possible that the ribbon was not loaded correctly, check the Ribbon Ink In and Ink Out Switch is in the correct position. • Darkness setting may be too high, reduce darkness setting • You may need to adjust the media edge guide and use/adjust the Media roll holder. • Incorrect or uneven printhead pressure, adjust Printhead Pressure and Toggle Position. • Adjust the ribbon tension bar, turn the tension bar screw clockwise to move the bar lower and decrease the tension. turn the tension bar screw counterclockwise to move the bar upper and increase the tension.
The printer is connected to the PC using a virtual COM port and printing stops. There are no errors.	Make sure that bidirectional support is disabled. From the printer properties dialog box, click the Ports tab, and then clear the Enable bidirectional support check box.
The printer is connected to a serial port on the PC but the printer is not working.	Try these possible solutions: <ul style="list-style-type: none"> • Make sure the serial port settings are configured correctly. • Make sure the serial cable pinouts are correct and that the cable is not damaged. • If you have the Windows driver for an RS-232 printer installed on your PC, uninstall the driver.
The printer boot up time is slower than before.	Try these possible solutions: <ul style="list-style-type: none"> • Remove the USB device or use a new (blank) USB • The printhead may be failing. If part of the dotted line is missing, replace the printhead

Verifier Problems

Problem	Possible Solution
Inconsistent barcode grading	Avoid interfering with the printed media during verification
Poor grading	Try these possible solutions in order: <ul style="list-style-type: none"> • Clean the verifier glass and printhead • Calibrate the verifier

Problem	Possible Solution
Voiding good labels	Adjust the verification passing grade
Verifier is not functioning	Check if the verification type is set to Read/No Read or ISO 15415/15416
Rmax is low	Try these possible solutions in order: <ul style="list-style-type: none"> • Check the quality of the media • Use lighter non-glossy media
Minimum Edge Contrast low grading	Try these possible solutions in order: <ul style="list-style-type: none"> • Use a lighter, non-glossy media • Increase barcode size-X dimension
Symbol contrast low grading	Try these possible solutions in order: <ul style="list-style-type: none"> • Make sure that your print quality setting is appropriate for the type of media that you are using. • The printhead pressure may be too low; increase printhead pressure • Typical Rmin value for Direct Thermal media is 10-20% and Thermal Transfer media is less than 5%
Modulation low grading	Try these possible solutions in order: <ul style="list-style-type: none"> • Use a lighter, non-glossy media • Increase barcode size-X dimension
Defects low grading	Try these possible solutions in order: <ul style="list-style-type: none"> • Make sure that your print quality setting is appropriate for the type of media that you are using. • The printhead pressure may be too low; increase printhead pressure • There may be foreign particles on the media. Clean or replace the media • The printhead may be dirty. Clean the printhead.
Decodability low grading	Make sure that your print quality setting is appropriate for the type of media that you are using.

Networking Problems

Problem	Possible Solution
The Ethernet or wireless network connection is not working correctly	Try these possible solutions: <ul style="list-style-type: none"> • Make sure your network cable is securely connected to your printer and a straight pin-to-pin cable, not a crossover cable. • Make sure your PC is correctly configured for and connected to your network. • Make sure your printer is correctly configured for your network.

Restore Printer Defaults

To restore factory defaults on the printer, use the printer web page or the Main Menu on the printer. From the printer web page and the Main Men, you can choose to restore default network settings, keep or delete user-installed files, and to restore all system settings.

Restore Defaults from the Printer Web Page

Restore your printer's defaults from the printer web page if you are connected to a Wi-Fi or Ethernet network.

1. Start a web browser on your desktop PC.
2. In the address field, type the printer IP address and press **Enter**. The printer web page appears.
3. Click **Login** in the upper right corner of the screen. The Login page appears.
4. Type your Username and Password in the text fields and click **Login**.
5. Select **Services > Restore Defaults**. The Restore Defaults menu appears with none of the check boxes selected.
6. To restore all default settings, select all of the check boxes and then click **Restore**. You can also restore only the defaults for specific settings:
 - To restore the current network settings, select the **Network settings** check box.
 - To restore all applications, fonts, and other files you have installed on the printer, select the **User files** check box.
 - To restore all current system settings, select the **System Settings** check box.
 - To delete all verification results, select the **Verification Files** check box.
7. When you receive a message to reboot the printer on your desktop PC, click **OK** and restart the printer.

Restore Defaults from the Main Menu

Restore the printer's defaults from the **Tools** menu.

1. From the Ready screen, open the Main Menu.
2. Select **Tools > Restore Defaults**. The Restore Defaults menu appears with all items in the list selected by default.
3. To restore all default settings, continue with the next step. You can also change the settings that are restored as follows:
 - To keep the current network settings, clear the **Network settings** check box.
 - To keep all applications, fonts, and other files you have installed on the printer, clear the **User files** check box.
 - To keep all current system settings, clear the **System Settings** check box.
 - To keep verification results, clear the **Verification Files** check box.
4. Tap the right arrow and, when prompted, tap **Yes** to restore default settings and reboot. A confirmation message appears.
5. To return to the Main Menu without restoring the default settings, select **No**. To return to the Restore Defaults list without restoring any defaults, select **Cancel**.

Restore Defaults with a Hardware-Based Reset

Restore the printer defaults by performing a hardware-based reset.

1. Turn the printer off and open the media cover.
2. Turn the printhead lift lever counterclockwise to raise the printhead.
3. Turn the printer on while pressing and holding the **Feed** button.
4. Release the Feed button when the status bar is nearly full.
5. All the settings are restored on the printer.
6. Turn the printhead lift lever clockwise to lower the printhead and close the media cover.

Upgrade the Printer Firmware

Check for periodic updates to the printer firmware. The latest version of the firmware is available from the Honeywell Technical Support Downloads portal (<https://hsmftp.honeywell.com>). Go to **Software > Printers > Industrial > PX940A PX940V > Current > Firmware**

You can upgrade the printer firmware using:

- The printer web page, a USB storage device, or PrintSet 5

Note: After you upgrade the printer firmware, restore the default settings and calibrate the media sensors.

Upgrade Firmware from the Printer Web Page

1. Start a web browser on your desktop PC.
2. In the address field, type the printer IP address and press **Enter**. The printer web page appears.
3. Click **Login** in the upper right corner of the screen. The Login page appears.
4. Type your Username and Password in the text fields and click **Login**.
5. Click the **Services** tab and select **Firmware Upgrade**. The Firmware Upgrade screen appears, showing the current firmware version.
6. Click **Browse** to locate the upgrade file. Select it and click **Open**.
7. Click **Upgrade**. The printer web page shows that it is upgrading firmware on your printer.

Upgrade Firmware from a USB Storage Device

Place the upgrade file in the root directory on the USB storage device.

Note: For best results, use a USB storage device that contains no other files besides the upgrade file.

1. Copy the firmware upgrade file to the root directory of the USB storage device.
2. Turn the printer off.
3. Insert the USB storage device into a USB host port.
4. Restart your printer. An upgrading firmware message appears as the upgrade file is loaded into the printer memory. This process may take a few minutes.
5. Remove the USB storage device.

Clean the Printer



Warning: Disconnect the power cord from the socket-outlet before installing user-service parts in the printer.

To properly maintain the printer, you should clean it regularly. You can clean these parts of the printer:

- Printhead
- Platen roller
- Media guides
- Media path
- Verifier
- Exterior of the printer

Caution: To avoid possible personal injury or damage to the printer, never insert any pointed or sharp objects into the printer.



Caution: Use only the cleaning agents specified in this section. Honeywell is not responsible for damage caused by any other cleaning materials used on this printer.

Caution: Isopropyl alcohol is a highly flammable, moderately toxic, and mildly irritating substance.

Follow these guidelines for cleaning the printer:

- Always remove the power cord before cleaning.
- Never spray the printer with water. Protect it from water when cleaning the premises.



Caution: Do not spray the printer with water. If you are using a hose to clean the premises in an industrial environment, remove the printer or protect it carefully from spray and moisture.

Clean the Printhead

Warning: The printhead/motor may be hot. Allow the printhead/motor to cool.

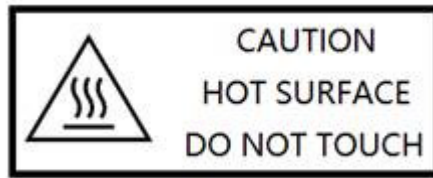

Cleaning the printhead on a regular basis is important for the life of the printhead and for the print quality.

Note: Honeywell recommends cleaning the printhead each time you replace the media.

Follow this procedure to clean the printhead using the cleaning card. If you need to clean additional residue from the platen roller or tear bar, use a cotton swab moistened with isopropyl alcohol.



Caution: Carefully read the warning text on the envelope before using the cleaning card.



Caution: Never use any sharp tools for removing stuck labels. The printhead and rollers are delicate.

1. Turn the printer off and disconnect the printer from power.
2. Open the media cover.
3. Remove the media and ribbon (if installed).
4. Insert most of the cleaning card under the printhead, and then lower the printhead.
5. Pull out the cleaning card and raise the printhead.
6. Wait for approximately 30 seconds to allow the cleaning fluid to dissolve the residue.
7. Repeat Steps 4 through 6 if necessary.
8. If necessary, clean residue from the platen roller or tear bar with a cotton swab moistened with isopropyl alcohol.
9. Once the parts are dry, replace the media (and ribbon) in the printer.
10. Close the media cover, reconnect power, and turn on the printer.

Clean the Front Sensor (PX940A)

Both the upper and lower of front sensor are transparent to allow light to pass between the two parts of the label gap and label mark sensors. It is important to keep these surfaces free of dust, stuck labels, and adhesive residue.

1. Turn the printer off and disconnect the printer from power.
2. Open the media cover.
3. Lift the front sensor arm and clean both the upper and lower of front sensor with a soft, lint-free cloth soaked in isopropyl alcohol.
4. Once the parts are dry, close the front sensor.

Clean the Verifier (PX940V)

Clean the verifier at the end of every roll of media to accurately verify the barcode. It is important to keep the verifier surface free of dust, stuck labels, and adhesive residue.

1. Turn the printer off and disconnect the printer from power.
2. Open the media cover.
3. Lift the verifier arm and clean the glass with a soft, lint-free cloth soaked in isopropyl alcohol.
4. Once the parts are dry, close the verifier arm and reconnect power to the printer.

Clean the Media Path

Both the upper and lower media guides are transparent to allow light to pass between the two parts of the label gap and label mark sensors. It is important to keep these surfaces free of dust, stuck labels, and adhesive residue.

1. Turn the printer off and disconnect the printer from power.
2. Open the media cover.
3. Remove the media and ribbon (if installed).
4. Insert a cleaning card or a soft cloth soaked in isopropyl alcohol between the two media guides to clean them.
5. Wait for approximately 30 seconds to allow the cleaning fluid to dissolve the residue.
6. Once the parts are dry, replace the media (and ribbon) in the printer.
7. Close the media cover, reconnect power, and turn on the printer.

Clean the Exterior of the Printer

Keep the exterior of the printer clean. Maintaining a clean exterior will reduce the risk of dust or foreign particles reaching the inside of the printer and affecting printer function.

Use a soft cloth moistened with water or a mild detergent when cleaning the printer exterior. Keep the surface surrounding the printer clean as well.

Replace the Printhead

You need to replace the printhead periodically when it wears out due to the rapid heating and cooling process used during printing. How often you need to replace the printhead depends on factors such as what type of images you print, the type of media or ribbon you use, the amount of energy to the printhead, the print speed, and the ambient temperature of the room you print in. The firmware detects the new printhead when you restart the printer.

1. Turn the printer off and disconnect the printer from power.
2. Open the media cover.
3. Remove the media and ribbon (if installed).
4. Turn the printhead lift lever counterclockwise to raise the printhead.
5. Pull down the Front Sensor(PX940A)/Verifier(PX940V).
6. Move the inside toggle and outside toggle to the center of printhead.

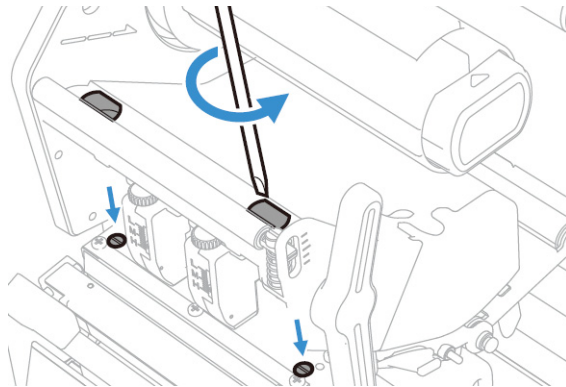

Note: Use a long screwdriver and the guiding holes to access the screws.

7. Use the screw driver to loosen the left and right screws.
8. Disconnect the two cables from the printhead as you remove it from the printer.
9. Connect the two printhead cables to the new printhead.
10. Insert the new printhead to the bracket into the printer.
11. Turn the printhead lift lever clockwise to close it.

12. Fasten the left and right screw.
13. Lock the Front Sensor(PX940A)/Verifier(PX940V) module back to the printer.
14. Replace the media (and ribbon) in the printer.
15. Close the media cover, reconnect power, and turn on the printer.

Replace the Platen Roller

If the printer platen roller gets damaged or wears out, it may need to be replaced.

1. Turn the printer off and disconnect the printer from power.
2. Open the media cover.
3. Remove the media.
4. Turn the printhead lift lever counterclockwise to raise the printhead.

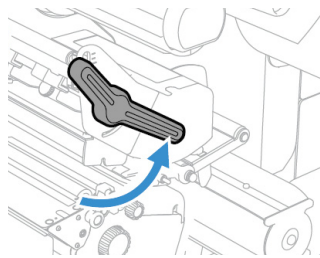

5. Pull out the verifier or front sensor knob toward the outside.
6. Pull down the front sensor (on PX940A model) or the verifier module (on PX940V model) toward the front side.

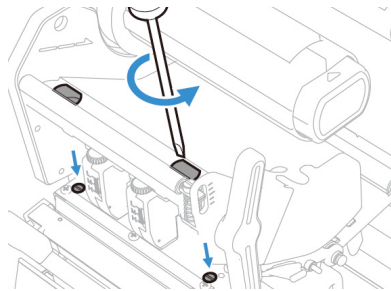

7. Rotate the platen roller latch clockwise to detach it from the printer and pull the platen roller away from the printer.

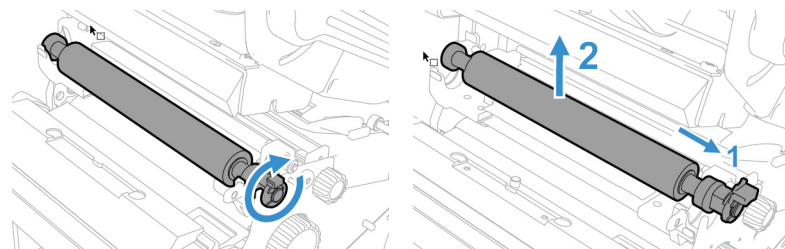

8. Insert the new platen roller and slide it into the printer.
9. Lock the platen roller by rotating the latch clockwise.

Label Taken Sensor Calibration

If your printer has the optional label taken sensor or the label dispenser (which includes the sensor), use the wizard to calibrate the sensor for your media.

Note: For best results, calibrate the sensor each time you load media or move the printer to a different environment. If you installed the label taken sensor module or the label dispenser in the printer, calibrate the sensor before you begin printing.

Before you calibrate the sensor, load media and ribbon in the printer as necessary.

1. In the Main Menu, select **Wizards > Calibration > Label Taken Sensor**.
2. Follow the prompts to calibrate the sensor.

Label Gap and Black Mark Sensor Adjustments

The label gap sensor is a transmissive sensor that controls how the printer feeds media by detecting gaps between the labels. The black mark sensor is a reflective sensor that detects black marks on continuous media.

The sensor contains a blue LED that is strong enough to see through media. You can use the blue LED to help determine the proper location for the sensor.

1. Open the media cover.
2. Adjust the label gap and black mark sensor:
 - Turn the sensor adjustment knob counterclockwise to move the sensor toward the outside of the printer.
 - Turn the sensor adjustment knob clockwise to move the sensor toward the inside of the printer.

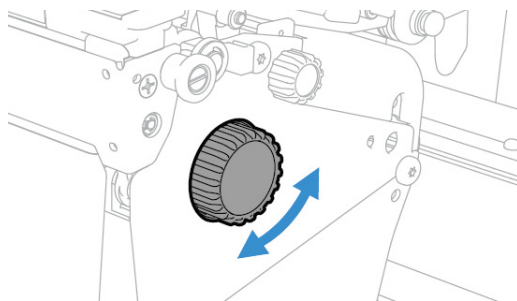

3. Close the media cover.

Printer and Environmental Specifications

1. Go to sps.honeywell.com and navigate to the PX940 product page.
2. Click on the **Resources** tab for Printer and Environmental Specifications.

Command Languages and Simulator Support Features

- Autosense
- Fingerprint
- Direct Protocol
- IPL
- ZSim
- DPL
- Smart Printing C#

Print Sensors

- Dual label gap/tag notch
- Black mark
- Printhead lift
- Media low
- Ribbon present/end
- Ribbon low
- Front arm lift
- Label taken (optional)

Network Services

- FTP
- SFTP
- HTTP/HTTPS
- SNMP v1/2c
- SNMP client support for IPv4 and IPv6
- WINS for IPv4
- BOOTP for IPv4
- DNS client support for IPv4 and IPv6
- Line Printer Protocol
- Raw TCP (Telnet in/out)
- DHCP client for IPv4 and IPv6 network (dual stack)
- IPv4 and IPv6
- Ping
- IPSEC/IKEv2 over IPv6
- SSH
- NTP
- Supports 10/100Mbps Ethernet (10BASE-T, 100BASE-T)
- Sentience

Fonts

Resident Fonts

- Andale Mono
- Andale Mono Bold
- CG Times
- CG Times Bold
- CG Triumvirate Condensed Bold
- Century Schoolbook Roman
- Dutch 801 Roman
- Honeywell Sans TT Bold
- Letter Gothic
- MHeiGB18030C-Medium
- Monospace 821
- Monospace 821 Bold

- OCR A
- OCR B
- Univers
- Univers Bold
- Univers Condensed Bold
- Univers Extra Condensed

Downloadable Fonts

For broader language and character support, any Unicode TrueType or TrueType-based OpenType font may be downloaded. Fonts from Monotype Imaging are recommended to address global languages. The fonts below have been tested and are available for purchase and download at www.fonts.com.

WorldType Collection fonts support all global languages whereas the other fonts listed support specific languages.

- Angsana New Regular
- Helvetica World
- MSung PRC Medium
- MSung HK Medium
- HYGothic-Medium
- TBMInPro-Light
- NarkisClassicMF
- WorldType Collection J
- WorldType Collection K
- WorldType Collection S
- WorldType Collection T

Supported Font Types

- TrueType
- OpenType
- Bitmap

Printed Barcode Symbologies

1D Barcode Symbologies

- Codabar
- Code 11

- Code 39
- Code 93
- Code 128
- DUN-14/16
- EAN
- HIBC 39
- HIBC 128
- Industrial 2 of 5
- Interleaved 2 of 5
- ISBT-128
- Matrix 2 of 5
- Straight 2 of 5
- UPC

2D Barcode Symbologies

- Aztec
- Code 16K
- Code 49
- Data Matrix
- DotCode
- Grid Matrix
- MaxiCode
- MicroPDF417
- MSI (modified Plessey)
- PDF417
- Planet Code
- Plessey Code
- Postnet
- QR Code
- RSS-14
- USPS 4-State Customer barcode

Graphic File Types

- PCX
- PNG
- GIF
- BMP

DEFAULT SETTINGS

Use this appendix to view the printer's factory default settings.

Communications Settings

Serial Port

The printer must be connected to the PC through a serial port to view the settings:

- From the printer Main Menu, select **Settings > Communications > Serial > COM1**.
- From the printer web page, click the **Configure** tab. Go to **Communications > Serial**.

Serial Port Setting	Description	Default
Baud Rate	Transmission speed in bits per second (bps) for the serial port.	115200
Data Bits	Number of bits that define a character or byte.	8
Parity	Specifies how the printer checks the integrity of the transmitted data.	None
Stop Bits	Number of bits sent at the end of every character to allow the receiving signal hardware to detect the end of a character and to resynchronize with the character stream.	1
Hardware	Specifies if hardware flow control (RTS/CTS) is used to manage the rate of data transmission between the device and the host.	Disable
ENQ/ACK	Specifies if software flow control (ENQ/ACK) is used to manage the rate of data transmission between the device and the host.	Disable
XON/XOFF To	Specifies if software flow control (XON/XOFF) is used to manage the rate of data transmission to the host.	Disable
XON/XOFF From	Specifies if software flow control (XON/XOFF) is used to manage the rate of data transmission from the host.	Disable
New Line Character	Defines the characters that the printer echoes to the host to indicate that it has moved to a new line.	CR/LF

Ethernet

To view these settings:

- From the printer Main Menu, select **Settings > Communications > Ethernet**.
- From the printer web page, click the **Configure** tab. Go to **Communications > Ethernet**.

Ethernet Setting	Description	Default
(IPv4) IP Assignment Method	Specifies how the printer obtains an IP address.	DHCP
(IPv4) IP Address	Specifies the unique network-level address that is assigned to each device in a TCP/IP network (IPv4).	0.0.0.0
Subnet Mask	Specifies a number that defines the range of IP addresses that can be used in a TCP/IP network.	0.0.0.0
Default Router	Specifies the IP address of a router that is used when a device sends a packet to another subnet or to an unknown destination.	0.0.0.0
DHCP Response	Specifies if the printer receives DHCP responses by broadcast or unicast.	Broadcast
(IPv6) IP Assignment Method	Specifies how the printer obtains an IP address (for IPv6 networks).	Automatic
(IPv6) IP Address	Specifies the unique network-level address that is assigned to each device in a TCP/IP network (IPv6).	Automatic

Bluetooth Settings

To view these settings:

- From the printer Main Menu, select **Settings > Communications > Bluetooth**.
- From the printer web page, click the **Configure** tab. Go to **Communications > Bluetooth**.

Bluetooth Setting	Description	Default
Device Name	Sets the name that identifies the printer in the Bluetooth network. Maximum length is 16 characters.	Printer model number and serial number.

Media Settings

To view these settings:

- From the printer Main Menu, select **Settings > Printing > Media**.
- From the printer web page, click the **Configure** tab. Go to **Printing > Media**.

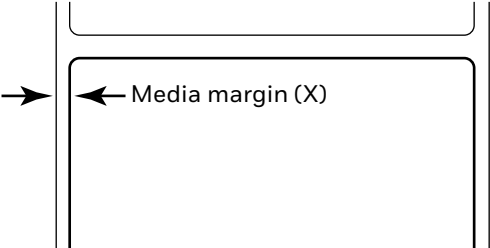
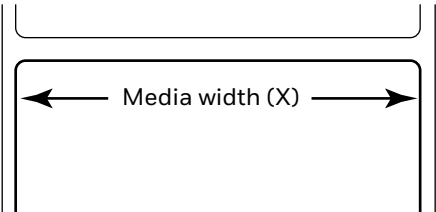
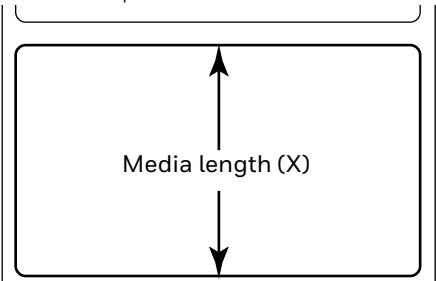
Media Setting	Description	Default
Media Type	Selects the type of media that is loaded in the printer.	Media With Gaps
Print Method	Selects the method of printing that the printer is using.	Ribbon (TTR) for thermal transfer printers, or No Ribbon (DT) for direct thermal printers
Media Margin (X)	<p>Sets the width of the margin from the left edge of the label along the printhead to the edge of the printable area. Unit of measurement is defined in the Unit of Measurement parameter.</p> 	Variable
Media Width	<p>Sets the width of the printable area measured from the media margin (X) across the printhead. Unit of measurement is defined in the Unit of Measure parameter.</p> 	Variable
Media Length	<p>Sets the length of the printable area measured from one edge of the label to the edge that is closest to the printhead. Unit of measurement is defined in the Unit of Measurement parameter.</p> 	Variable
Clip Default	<p>Determines if the printer prints items outside the printable area of the label. When this is set to Off, the printer returns an error if any part of a barcode label cannot be printed because that part extends beyond the printable area. When this is set to On, the printer prints all barcode labels, but may also print unreadable, incomplete labels.</p>	Off
Print Mode	Selects the printer tear off, peel off, or rewind media mode	Tear Off

Media Setting	Description	Default
Peel Strength	Selects strength the printer uses to peel the label off from liner. Use Medium or High if the printer has trouble to peel certain types of media.	Low
Label Top Adjust	Sets the length of media the printer feeds (positive value) or retracts (negative value) before printing a label. Unit of measurement is defined in the Unit of Measure parameter. Range is -9999 to +9999.	0
Label Reset Adjust	Sets the length of media the printer feeds (positive value) or retracts (negative value) after printing a label. Unit of measurement is defined in the Unit of Measure parameter. Range is -9999 to +9999.	0
Media Calibration Mode	Selects the mode the printer uses to calibrate media. Use Slow if the printer has trouble identifying gaps or marks in media. Use Fast with Retraction or Slow with Retraction to retract the media and ribbon fed for calibration back to the printer.	Slow
Length (Slow Mode)	If Media Calibration Mode is set to Slow, the printer prints the media length plus 10 mm. This value sets an additional amount of media to be printed. Unit of measurement is defined in the Unit of Measurement parameter. Range is 0 to 3200.	0
LTS Sensitivity Level	Sets the sensitivity of the label taken sensor.	0
Power Up Action	Sets the action when you turn the printer on: No Action Form feed: The printer feeds one label. Test feed: The printer prints two configuration labels as it calibrates the media sensors. Smart Calibration: Detects media type (gap, black mark, or continuous, detects printing method (ribbon or no-ribbon), and calibrates media length.	Smart Calibration
Head Down Action	Sets the action when you close the print mechanism after opening it: No Action Form feed: The printer feeds one label. Test feed: The printer prints two configuration labels as it calibrates the media sensors. Smart Calibration: Detects media type (gap, black mark, or continuous, detects printing method (ribbon or no-ribbon), and calibrates media length.	Smart Calibration
Hold Feed Button Action	Sets the action when you press and hold the Print button for more than 2 seconds: Test feed: The printer prints two configuration labels as it calibrates the media sensors. Smart Calibration: Detects media type (gap, black mark, or continuous, detects printing method (ribbon or no-ribbon), and calibrates media length.	Smart Calibration
Label Counter	Specifies a label counter (from 1 to 49) that SNMP uses to report media counts.	0 (off)

Note: If no action is selected for Head Down Action, then you need to align the media gap, black mark, hole, and notch with the tear bar before you close the printhead at Thermal Transfer printing mode. Otherwise, the first label may be printed by the used ribbon.

Print Quality Settings

To view these settings:

- From the printer Main Menu, select **Settings > Printing > Print Quality**.
- From the printer web page, click the **Configure** tab. Go to **Printing > Print Quality**.

Print Quality Setting	Description	Default
Print Speed	Sets how fast the printer prints labels. The unit of measure is defined in the Unit of Measure parameter.	200dpi:100 300dpi:100 600dpi: 50
Media Sensitivity	Sets the level of sensitivity of the media to the printhead heat for media and ribbon.	High
Darkness	Sets the image darkness for media and ribbon. Adjust this parameter with the Media Sensitivity parameter. Range is 1 to 100.	55
Contrast	Adjusts the blackness of the printing on the label in 2% increments from -10% to +10%.	+0%
Label Rotation	Rotates the label 0, 90, 180, or 270 degrees	0
Enhance Text	Enable/disable enhance text. Enable enhance text to improve text print results, Disable enhance text to keep barcode print results	Disabled

About Label Rotation

Rotation Point and Rotation Radius

Rotation radius (RR) is a linear distance of rotation axis where image rotates about its rotation point (RP).

Each rotation type has different rotation point. For 90-degree rotation, the rotation point is located at the bottom left of image buffer, while for 270-degree rotation, the rotation point is located at top left of the image buffer. The original image will be rotated (90 or 270-degrees) and then translated up or down to fit the label. The new origin point will be most bottom left of image buffer.

For media type **Media With Gaps, Black Mark, and Continuous Fix Len**:

- Rotation radius determine by the rotated media length and width. For landscape label where label length is shorter than label width, label width will be used as rotation radius. For portrait label where label length is longer than label width, label length will be used as rotation radius, however if label length exceeds TPH width, TPH width will be used as rotation radius. For square label where label width and length are same, both label width or length will be used as rotation radius.
- To get correct rotation result, user should set the media width and length settings accordingly to the rotated media width and length (Loaded physical

label to printer). Media length can be set accurately by running media calibration at Wizards->Calibration->media.

For media type **Continuous Var Len**, rotation radius determine by the rotated media width. To get correct rotation result, user should set the media width settings accordingly to desired rotated media width.

Rotation Scenarios

Legend

- RR** = Rotation Radius
- RP** = Rotation Point
- - ▷ - -** = Rotate Direction
- - - - ▷** = Translation Shift

Landscape Label (2x4 image to 4x2 label)

90-degree rotation:

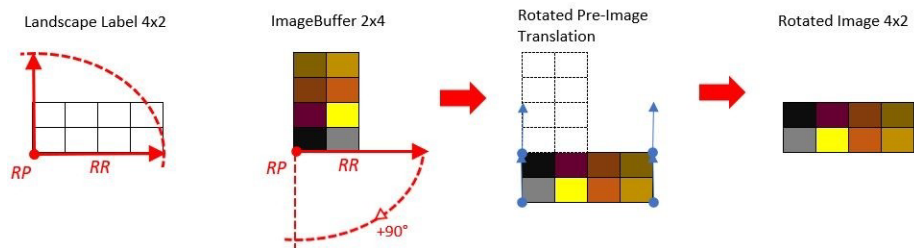

270-degree rotation:

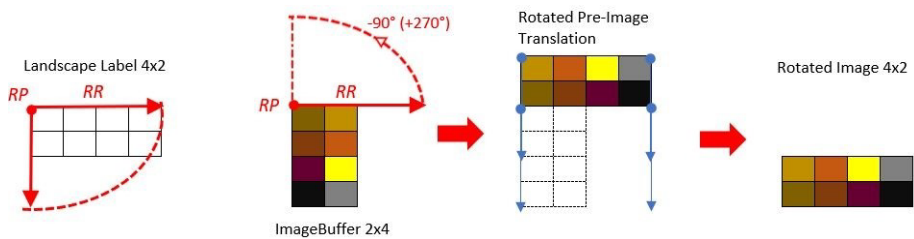

Portrait Label (4x2 image to 2x4 label)

90-degree rotation

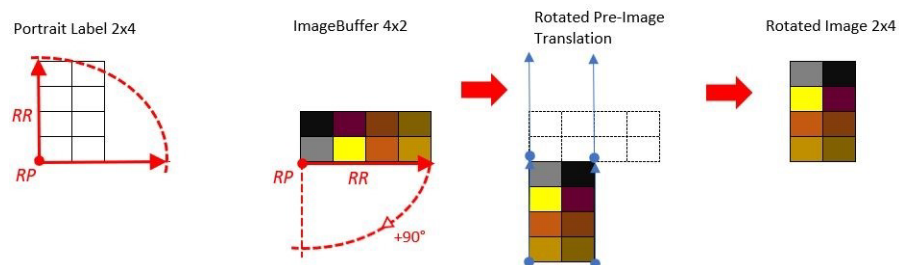

270-degree rotation

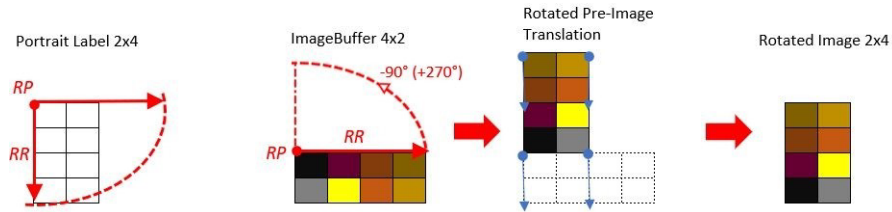

Square Label (3x3 image to 3x3 label)

90-degree rotation

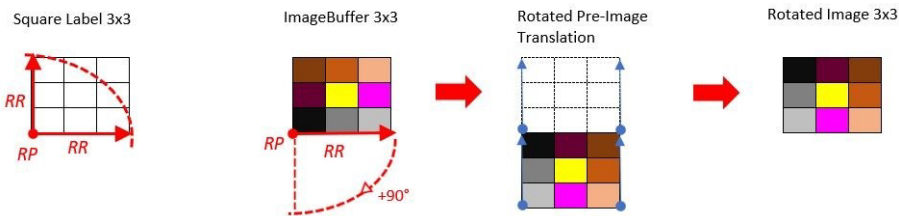

270-degree rotation

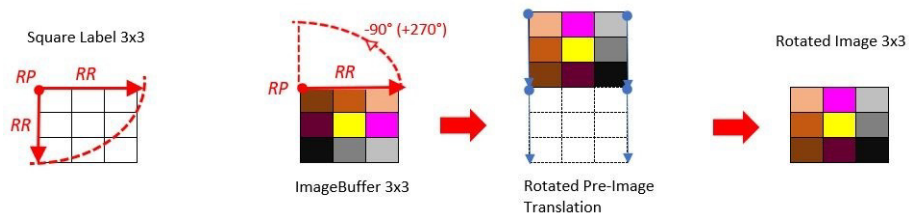

Portrait Label (Label length > TPH width, 4x6 image to 4x6 label)

90-degree rotation

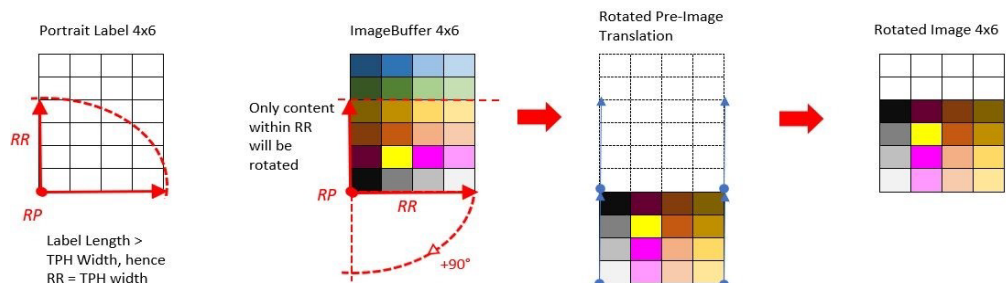

270-degree rotation:

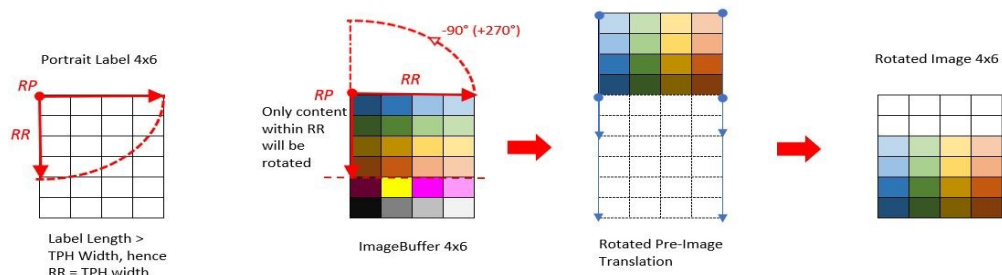

Portrait Label (Label length > TPH width, 6x4 image to 4x6 label)

90-degree rotation:

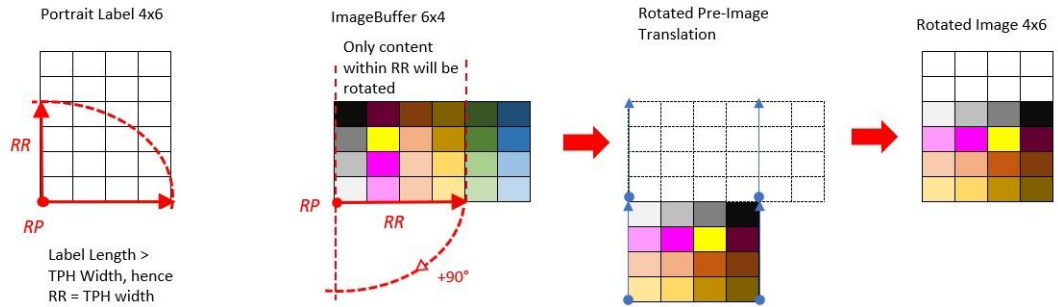

270-degree rotation:

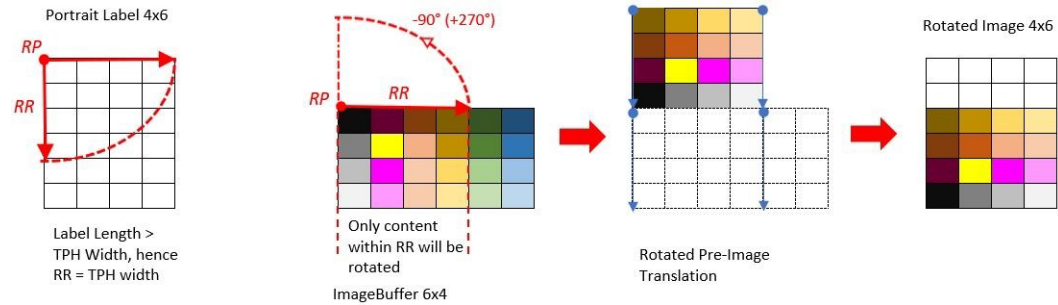

Media Margin (X) (dots) and Label Top Adjust (dots)

You can adjust the rotated label in X direction by setting the Media Margin (X) (dots) at **Printing > Media > Media Margin (X) (dots)**, range from -60 to printer supported width.

You can adjust the rotated label in Y direction by setting the Label Top Adjust (dots) at **Printing > Media > Label Top Adjust (dots)**.

Both settings provide the ability to move the rotated image to a point of interest in both X and Y directions.

System Settings

General System

To view these settings:

- From the printer Main Menu, select **Settings > System Settings > General**.
- From the printer web page, click **Configure > System Settings > General**.

General System Setting	Description	Default
System Name	Sets the network identification name (WINS name) of the printer.	Printer model number and serial number.
System Location	Sets the location of the printer.	Empty string
System Contact	Sets the name of the printer administrator.	Empty string
XML Response Mode	Determines if the printer provides XML responses to printing requests (over Telnet and HTTP).	False
Display Language	(LCD printers only.) Selects the language the printer uses to display text on the screen.	English
Display Language (Web Page)	Selects the language the printer uses to display text on the web page.	English
Keyboard Input	Selects the language of the external keyboard that is connected to the printer.	U.S./U.K.
Time	Sets the current time.	System time
Date	Sets the current date.	System date
Command Language	Sets the printer command language. If changed, requires restart.	Autosense
Alert Notification Method	Selects how you want the printer to notify you of printer alerts.	SNMP Trap + Email
Unit of Measure	Selects the unit of measure that is used to define several printing parameters.	Dots
Zero with Slash	Determines how the zero character is printed and displayed on the screen. Disable (0) or Enable (Ø).	Disable
Time Zone	Sets the time zone.	(UTC 00:00) Universal Time
DST Adjust	Determines if Daylight Saving Time is automatically adjusted.	Disable

Display and Audio Settings

To view these settings:

- From the printer Main Menu, select **Settings > System Settings > Display or Audio**.
- From the printer web page, click **Configure > System Settings > Display or Audio**.

Display and Audio Setting	Description	Default
Brightness	Selects the brightness of the printer screen.	Low
Idle Information	Selects the information that appears on the printer screen when it is in Idle mode.	IPv4 address
Time Format	Selects the format used to display time on the printer.	24 Hour
Date Format	Selects the format used to display date on the printer.	dd/mm/yyyy
Menu Access	Determines if the Menu button on the printer web page is accessible.	Enable
PIN	Sets the password that allows access to the Menu button on the printer web page, if the Menu Access parameter is set to Enable With PIN. Range is 4 to 16 characters.	1234
Screen Timeout	Selects how long the printer screen stays on before the screen saver starts.	Disable
Feed Key Access	Determines if the Feed button on the printer keypad is enabled or disabled.	Enable
Information Access	Determines if the information bar on the Main Menu is accessible.	Enable
Volume	Sets the printer volume.	Off

Note: PX940 printers are Energy Star qualified, but require the brightness set to Low and power consumption may vary in actual application with Applicator Board or Industrial Interface Board. Energy Star is qualified only for Non-Applicator or Non-Industrial Interface.

System I/O

To view these settings:

- From the printer Main Menu, select **Settings > System Settings > Manage I/O**.
- From the printer web page, click **Configure > System Settings > Manage I/O**.

System I/O Setting	Description	Default
Ethernet	Determines if the printer is allowed to communicate using Ethernet communications.	Enable
Wireless 802.11	Determines if the printer is allowed to communicate using its 802.11 radio. Supported only if the optional Wi-Fi module is installed.	Enable
Virtual COM	Determines if you can enable the USB port to be used as a virtual serial port. When you change this setting, you must restart the printer to enable the new setting.	Disable

System Network Services

Note: You will only see **Manage Services** from the menus if you have an Ethernet or Wireless module installed in the printer.

Note: The printer supports 10/100 Mbps Ethernet (10BASE-T, 100BASE-T)

To view these services:

- From the printer Main Menu, select **Settings > System Settings > Manage Services**.
- From the printer web page, go to **Configure > System Settings > Manage Services**.

System Network Service Setting	Description	Default
Web Server	Determines if the web server is enabled in the printer.	Enable
FTP	Determines if the printer can use File Transfer Protocol.	Disable
SFTP	Determines if the printer can use Secure File Transfer Protocol	Enable
Avalanche	Determines if the printer can be managed by Wavelink Avalanche.	Enable
Net1	Determines if the printer can use Telnet to communicate with Fingerprint.	Enable
SNMP	Determines if the printer can use SNMP.	Enable
LPR	Determines if the printer can use the line printer server (LPR) daemon.	Enable
IKEv2	Determines if the printer can use IKEv2.	Disable
SSH	Determines if the printer can use Secure Socket Handling (SSH).	Disable
Telnet	Determines if the printer can use Telnet.	Disable
XML	Determines if the printer can use XML printing.	Enable
Time Server	Determines if the printer uses the Network Time Protocol (NTP) to synchronize its time with a network time server. The default Server Address is ntp0.cornell.edu , and the default Port Number is 123 .	Disable
Device Management	Determines if the printer can use 9300 TCP/IP port to communicate with HCD.	Disable
Connectivity Agent	Determines if the printer can communicate with Honeywell Cloud on port 10000.	Disable

Verification Settings

Verifier Setting	Description	Default
Verification Type	Select the verification type to check the barcode. None - No barcode validation Read/No Read - Validate if barcode is readable ISO15415/15416 - Full ANSI grading of barcode	ISO15415/15416
Passing Grade	Sets the minimum passing grade for barcode grading. Grade 0.0 (F) is the lowest grade. Grade 1.5 (C) is the default and recommended by ISO standard. Only applied when verification type is set to ISO15415/15416.	1.5 (C)
Aperture	Indicates the aperture size (in mils) used for verification. Aperture size will be chosen automatically based on ISO standard. Change only if required by an overriding application.	Automatic
Report Level	for ISO 15415/15416 setting. Level 1 - No logging Level 2 - Label grade Level 3 - Label grade, and barcode grade Level 4 - Label grade, barcode grade, and barcode ANSI grading details Level 5 - All details including 10 scan line data	Level 4

Error Handling Settings

Error Handling	Description	Default
MaxConsecutive Failures	Sets maximum number of times printer encountered verification failure consecutively before prompting for user action. This setting is only applicable when the Verification Failure Action is set to Void and Reprint.	3
Verifier Failure Action	Indicates action to take when label fails verification. Void and Reprint (default) - Retract and void the failed label, then reprint the failed label. Stop reprint if the maximum consecutive failures have been reached. Ignore and Continue - No voiding when verification fails. Result is saved and next label is printed. Note: During multiple label printing, printer will void the failed label (plus all printed and yet to be verified labels) in order to keep the good labels in sequence.	Void and Reprint
Void Pattern	Select the void pattern type to mark the failed label.	Diamond

Error Handling	Description	Default
Max Void Length	Sets maximum coverage distance to mark the failed label with void pattern, starting from end of the label edge. The void pattern will not be printed over the next label if the label length is smaller than the setting. Minimum value: 3 mm or 0.118 in Maximum value: 305 mm or 12 in	305
Reprint Mode	Indicates reprint action to take when label fails verification. Sequential - Void the good labels if needed to keep good labels in the same order as sent to the printer. Non Sequential - Void only the failed label. The good labels may not be presented in order.	Non-Sequential
Grading Override	When enabled, the user is allowed to decide to accept the failed label (below the grading threshold) when prompted for user action when maximum consecutive failures count is reached.	Disabled
Verify Unsupported Barcode	Enable or disable barcode verification for unsupported barcode. When enabled, the label will be voided if unsupported barcode is printed.	Enable
Allow Abort	When enabled, the user is allowed the option to abort the print job of failed verification (below the grading threshold) when prompted for user action after maximum consecutive failures count is reached	Enable

Network Exporting Settings

Network Exporting	Description	Default
Server Address	Configures the IP address of the host FTP server, or 0.0.0.0 to disable data exporting	0.0.0.0
User Name	Configures the FTP user name the printer uses to login to the host FTP server.	None
Password	Configures the FTP password the printer uses to login to the host FTP server.	None
Interval	Configures the time interval that the printer will send verification data to the host FTP server. Data will only be sent if the connection to the host FTP server is successful. Range is 0-1440, 0 is immediate.	30 minutes
Report Format	Selects the report format to export and send to the host FTP server.	CSV
Remote Directory	Configures the FTP remote directory the printer uses to transfer files to the host FTP server.	[Printer System Name]
File Transfer Protocol	Selects the file transfer protocol type, FTP or SFTP.	FTP

Data Exporting Settings

Data Exporting Setting	Description	Default
Export To USB	When enabled, verification images and report files will be exported to USB drive automatically, stored in verifier folder. Note: - Saved Label Images must not be disabled, USB drive connected to printer must contain a folder named verifier in the root directory. - If no USB drive connected to printer, saved images and report files will be stored in /home/user/verifier/images.	Enable
Save Label Images	Selects the saving option for scanned labels. Label images and XML reports will be saved in non-volatile memory. Maximum 100 images and XML reports can be saved (if memory available). When memory is full or maximum capacity is reached, oldest image and XML report file will be replaced by newest.	Failed Labels only

Barcode Settings

Barcode	Description	Default
CODE39	Enable or disable barcode symbology verification	Enable
CODE128	Enable or disable barcode symbology verification	Enable
EAN8	Enable or disable barcode symbology verification	Enable
EAN13	Enable or disable barcode symbology verification	Enable
UPCA	Enable or disable barcode symbology verification	Enable
UPCE	Enable or disable barcode symbology verification	Enable
INT2OF5	Enable or disable barcode symbology verification	Enable
DATABAR	Enable or disable barcode symbology verification	Enable
COODE93	Enable or disable barcode symbology verification	Enable
DATAMATRIX	Enable or disable barcode symbology verification	Enable
QRCODE	Enable or disable barcode symbology verification	Enable

Verifier Integration Interface (VII) Settings

VII Setting	Description	Default
Execution Mode	Select the printer execution mode. Synchronous - A single label is printed, image grabbed and fully inspected before any other labels are printed Asynchronous - One label can be inspected while the next label is being printed and/or having its image grabbed	Asynchronous
Verifier Mode	Select the verifier mode. Scan - The verifier will not do barcode inspection. Scan & grade - The verifier will inspect barcode. Scan, grade & control - The verifier will inspect barcode and do failure action handling.	Scan, grade & control
Command Channel	Sets the port number of the command channel	9300
Feedback Channel	Sets the port number of the feedback channel	9301
Image Channel	Sets the port number of the image channel	9302

Maintenance Alerts

To view these settings:

- From the printer Main Menu, select **Settings > System Settings > Maintenance Alerts**.
- From the printer web page, click the **Configure** tab. Go to **System Settings > Maintenance Alerts**.

Maintenance Alerts Setting	Description	Default
Odometer (User Resettable)	Sets the length of media (in meters) that the printer prints before the Odometer (User Resettable) alert is sent, if this alert is configured. Unit of measurement is defined in the Unit of Measure parameter. Range is 0 to 4294967295.	0
Odometer (Printer)	Sets the length of media (in meters) that the printer prints before the Odometer (Printer) alert is sent. Unit of measurement is defined in the Unit of Measure parameter. Range is 0 to 4294967295.	0
Odometer (Printhead)	Sets the length of media (in meters) that the printer prints before the Odometer (Current Printhead) alert is sent, if this alert is configured. Unit of measurement is defined in the Unit of Measure parameter. Range is 0 to 4294967295.	0
Replace Printhead	Sets the length of media (in meters) that the printer prints before the Replace Printhead alert is sent, if this alert is configured. Unit of measurement is defined in the Unit of Measure parameter. Range is 0 to 4294967295.	0

Maintenance Alerts Setting	Description	Default
Clean Printhead	Sets the length of media (in meters) that the printer prints before the Clean Printhead alert is sent, if this alert is configured. Unit of measurement is defined in the Unit of Measure parameter. Range is 0 to 4294967295.	0
Faulty Dot	Sets the number of faulty dots on the printhead before the Faulty Dot alert is sent, if this alert is configured. Range is 0 to 4294967295.	0
Media Low Diameter	Sets the minimum diameter of the media roll before the Media Low alert is sent, if this alert is configured. Range is 0 to 200 mm.	0
Ribbon Low Diameter	Sets the minimum diameter of the ribbon roll before the Ribbon Low alert is sent, if this alert is configured. Range is 0 to 200 mm.	0
Memory Low	Sets the minimum percentage of free RAM memory and/or Flash memory before the Memory Low alert (if this alert is configured) is sent. Unit is percentage.	0
License Expired	Sets the number of days left before the "license expiring soon" alert is sent.	60

PRINT LABELS WITH INPRINT

The INPrint Page

The INPrint page features sample web forms you can use to print single labels if you are using the Fingerprint or Direct Protocol Language on your printer. Select a web form from the lists and enter information in the fields for that label. You can then preview and print the label.

The printer firmware includes several predefined label formats. You can also copy your own label formats to the printer and print them from the INPrint page.

Print INPrint Labels

If the printer is connected to an Ethernet or Wi-Fi network, you can print labels by entering information in a web form. Access the web forms through the printer web page.

1. Open a browser window on your PC.
2. In the location or address bar, type the printer IP address and press **Enter**. The printer web page appears.
3. Click the **INPrint** tab.
4. Select the web form you want to print:
 - If you created the web form yourself, click **Customer Downloaded** and then select the web form in the list.
 - To use one of the Honeywell resident web forms, click **Resident** and then select the web form in the list.
5. Type information in the web form as needed.

To preview the label on screen, click **Preview**. To print the label, click **Print**.

Printer Accessories and Options

Option/Accessory	PX940A/PX940V/Both	Description
Wi-Fi Module	Both	Customer installed accessory. Use the Wi-Fi module to communicate with the printer wirelessly.
Parallel IEEE1284 Interface Board	Both	Service technician installed accessory. Use the parallel interface board to make an applicator port on the back of the printer.
Applicator Interface Board	Both	Service technician installed accessory. Use the applicator interface board to make an applicator port on the back of the printer.
Industrial Interface+UART	Both	Service technician installed accessory. Use the industrial interface+UART board to make a UART port and GPIO port on the back of the printer.
Verifier Calibration Card	PX940V	Use this card to calibrate the verifier.

Note: To view the accessory manuals, visit the PX940 product page at sps.honeywell.com.

Honeywell
855 S. Mint Street
Charlotte, NC 28202

sps.honeywell.com