



FOTON 30

Automatic Laminator



start here



Quick Start Guide	3
Controls	4
Specification	4
Installation	5
Feature Guide	6
Operation	7
Troubleshooting	8
Safety	10





MODE

Feed Cut	
Auto	Auto
Manual	Auto
Manual	Manual

≤120gsm

30
A3/A4

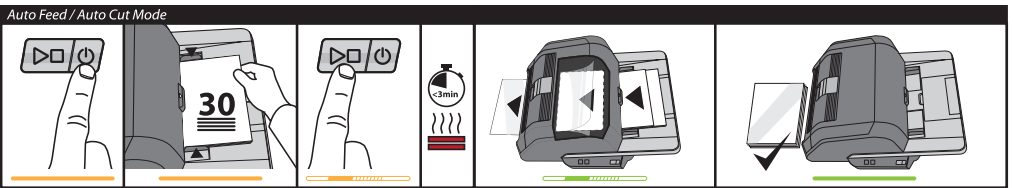

MODE

Feed Cut	
Auto	Auto
Manual	Auto
Manual	Manual

≥120gsm

01
A3/A4

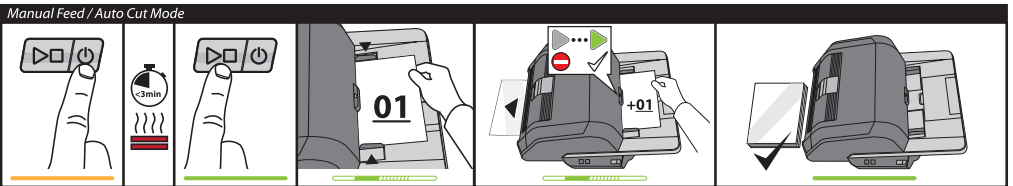





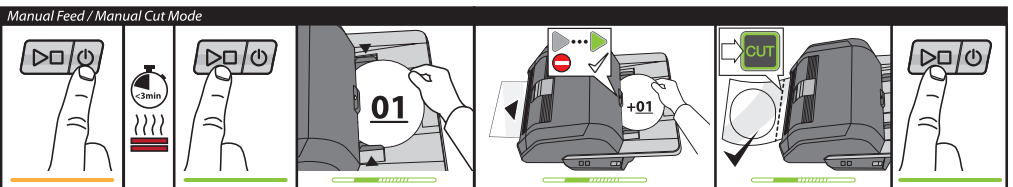

MODE

Feed Cut	
Auto	Auto
Manual	Auto
Manual	Manual

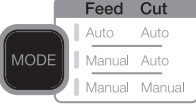

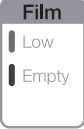

CONTROLS

 <p>Run/Stop Power</p>	<p>Power: turns on unit and begins warming process, press again to turn off.</p> <p>Run/Stop: Starts and stops lamination</p>
	<p>Mode: Press to cycle through operation modes.</p>
 <p>Status</p>	<p>Status indicator: used to indicate Warming, Ready, Running, and Error states.</p>
	<p>Manual Feed Ready indicator: used to indicate when to insert document in manual feed modes</p>
	<p>Activates Cutter: press while in Manual Feed / Manual Cut Mode to separate documents. Important! Verify completed document before use</p>
	<p>Film Status: <i>Low</i> indicates approx. 30 documents remaining. <i>Empty</i> indicates cartridge must be replaced to continue</p>
	<p>Error States: <i>Door</i> indicates a door is ajar. <i>Jam</i> indicates a document jam. <i>Cutter</i> indicates a cutter error</p>

Service

To register and activate the warranty go to www.gbceurope.com

For details of your local service representative go to www.gbceurope.com



Products marked with this symbol meet all applicable Community regulations for the European Economic Area.



Only use the laminator in indoor areas.

SPECIFICATIONS

Model	FOTON 30
Operating Speed	75 microns: 700mm/min 100 microns: 670mm/min 125 microns: 650mm/min
Operating Modes	Auto Feed / Auto Cut Manual Feed / Auto Cut Manual Feed / Manual Cut
Warm-Up Time	75 microns: 3 minutes 100 microns: 3.5 minutes 125 microns: 4 minutes
Maximum Feed Capacity	30 sheets (80gsm paper)
Maximum Film Width	306mm
Maximum Document Thickness	250gsm (Manually Fed)
Document Lengths Supported	Minimum: 152mm Maximum: 432mm
Document Widths Supported	Minimum: 127mm Maximum: 297mm
Auto Feeder Media Weight	High Reliability: 64-120gsm Variable Reliability: 121-220gsm
Manual Feeder Media Weight	64-250gsm
Dimensions • Width • Height • Depth • Weight	Machine 57.7cm 24.5cm 47.8cm 9.5kgs
Auto Shut-Off	After 15 minutes of inactivity
Electrical Requirements	220-240V, 50/60Hz
Fuse	Yes (internal & non-replaceable)
Operating Environment	5-35C Maximum Altitude of 2,000m

INSTALLATION

Service



WARNING: Do not attempt to service or repair the laminator. Failure to observe this warning could result in severe personal injury or death.

Disconnect the plug from the socket and contact Customer Service when one or more of the following has occurred.

- The power supply cord or attachment plug is damaged.
- Liquid has been spilled into the laminator.
- The laminator is malfunctioning after being mishandled.
- The laminator does not operate as described in these instructions.

Installation

- Shipping damage should be brought to the immediate attention of the delivering carrier.
- Place the laminator on a stable flat surface capable of supporting 23kg.
- The surface should be at least 0.75m high to assure comfortable positioning during operation. All four rubber feet should be on the supporting surface.
- Connect power cord to an appropriate power source. Avoid connecting other equipment to the same branch circuit to which the laminator is connected as this may cause nuisance tripping of the circuit breaker or blown fuses.
- The laminator should be positioned to allow exiting film to drop freely to a flat surface. Accumulation of laminated documents as they exit the laminator may cause a jam.
- Avoid placing laminator near sources of heat or cold. Avoid locating the laminator in the direct path of forced, heated or cooled air.

Caring for your Foton 30

The only maintenance required by the operator is to periodically clean the rollers. Keeping the rollers clean ensures that your finished items will not be damaged by dirt and adhesive build-ups.



CAUTION: the following procedure is performed while the laminator is hot. Use extreme caution.



WARNING: Do not apply cleaning fluids or solvents to the rollers.



WARNING: Do not attempt to laminate adhesives marked 'Flammable'.



WARNING: Do not expose laminator to liquids.

1. Power the machine on, wait for it to completely warm up.
2. Open the laminator door using the silver latch.
3. Clean the top rollers with a clean, damp lint-free cloth. If there are any adhesive build-ups, you may use isopropyl alcohol instead of water.
4. Lift leading film edge up to the handle of the cartridge.
5. Clean the bottom rollers with a clean, damp lint-free cloth. If there are any adhesive build-ups, you may use isopropyl alcohol instead of water.
6. Place the leading film edge into proper position and close the door.
7. Press and hold the RUN/STOP button for 5-7 seconds to manually advance the rollers.
8. Open the laminator door using the silver latch.
9. Repeat steps 3 – 6.

Note: Do not use metal scouring pads to clean the heat rollers!



WARNING: Do not laminate glitter and/or metallic items. Damage to the rollers may result.

The side covers, and feed table can be cleaned with a lint-free cloth and a mild detergent.

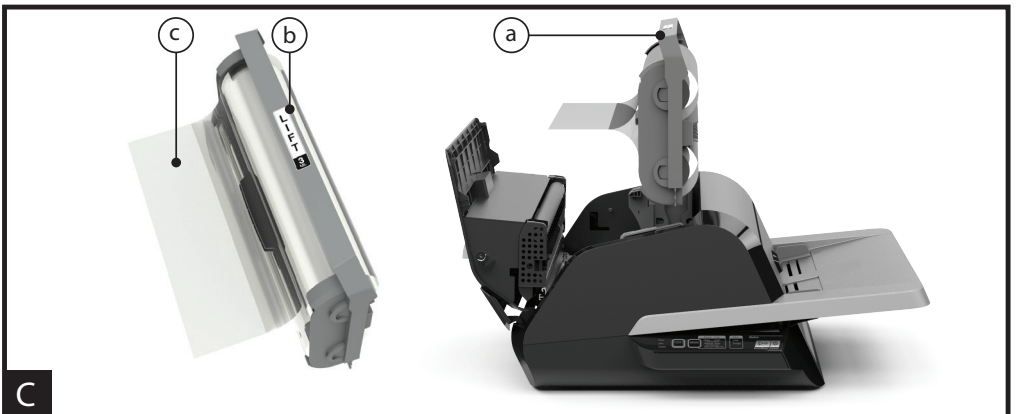
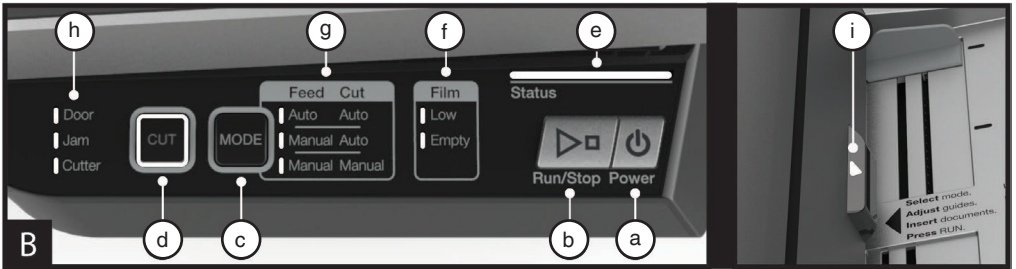
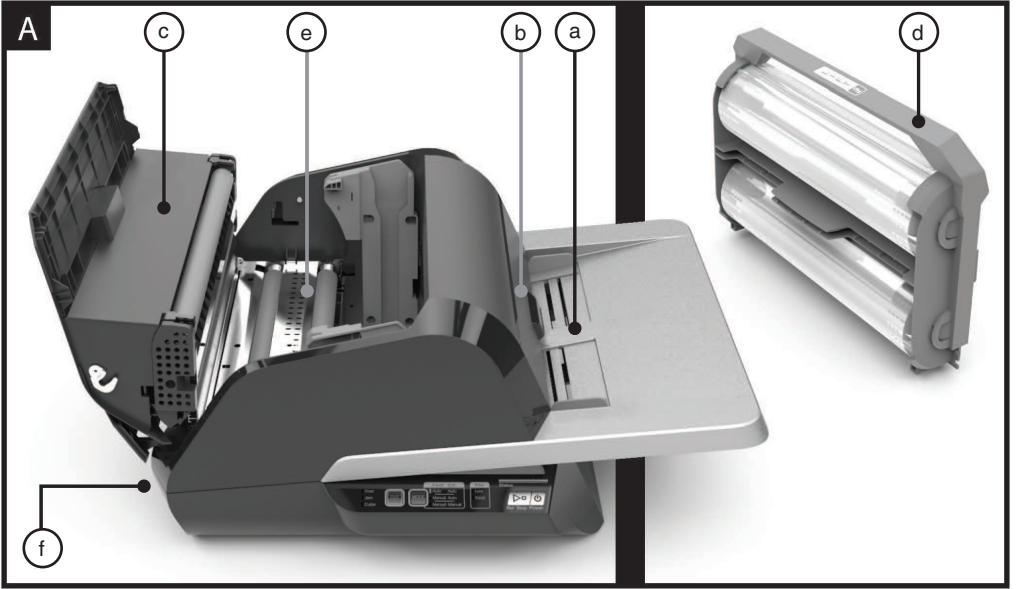

FEATURE GUIDE

A. GETTING TO KNOW YOUR LAMINATOR:

(Shown in image A above)

a) FEED TRAY & SIDE GUIDES:

- i) Place document(s) to be laminated and use the side guides to minimise skew. Flip out extension for larger documents.

b) FEEDER/FEEDER DOOR:

- i) Feeds document into laminator. A red light on the door will indicate that a mis-feed has occurred. Open the door to clear any mis-feeds.

c) LAMINATOR DOOR:

- i) Door that gives access to the inner parts of the laminator: rollers, film cartridge, etc.
- ii) To Open: pull on the silver latch, and lift up
- iii) To Close: gently lower using the silver latch, and push latch closed. DO NOT push down on the laminator door to close.

d) FILM CARTRIDGE:

- i) Replace the film cartridge when empty or when a different thickness is required. See CARTRIDGE FILM LOADING for details.

e) LAMINATORS ROLLERS:

- i) Rollers heat-up to activate the adhesive on the film and apply the pressure to ensure the film sticks to the document.

f) AUTO TRIMMER:

- i) When in Auto Cut modes, the trimmer finds the leading and trailing edge of the document and cuts the film. In Manual Cut mode, it will cut the film when the CUT button is pressed.

B. CONTROL PANEL:

(Shown in image B above)

BUTTONS

- a) **POWER** – turns the machine on/off. After 15 minutes of no use, the machine will automatically turn off.
- b) **RUN/STOP** – used to start and stop the laminator.
 - i) Dual Function – Manual Advance: Continuously hold the button to manually advance the laminator rollers. This can be used to clear jams and debris for cleaning.
- c) **MODE** – allows users to toggle through three modes of operation.
 - i) Auto Feed / Auto Cut – best for standard paper sizes printed on 80-120gsm paper.
 - ii) Manual Feed / Auto Cut – best for standard paper sizes on heavy paper stocks that won't Auto Feed.
 - iii) Manual Feed / Manual Cut – best for odd shaped and non- rectangular documents.

- d) **CUT** – pressing this button will cycle the trimmer to cut the film one time. This button is primarily used in Manual Cut mode.

INDICATORS

- e) **STATUS** – communicates the status of the machine:
 - i) Solid Green = ready to use
 - ii) Green Blinking Sequence = running
 - iii) Solid Amber = warming up
 - iv) Amber Blinking Sequence = warming up and RUN command accepted. Will begin laminating once ready.
 - v) Solid Red = error status
- f) **FILM** – LED light will indicate when film is low (approx. 30% remaining) or is empty.
 - i) Low = Amber LED light
 - ii) Empty = Red LED light
- g) **MODE** – green LED light identifies what mode of operation the machine is in.
- h) **ERROR MESSAGE** – communicates error messages that need to be resolved.
 - i) **DOOR**: one or both doors are open
 - ii) **JAM**: the machine may encounter two types of jams:
 1. Laminator jam: push and hold the RUN button to manually advance the rollers to clear itself.
 2. Feeder jam: open the feeder door and remove the paper.
 - iii) **CUTTER**: trimmer cannot complete full cut cycle
- i) **MANUAL FEED INDICATOR** – communicates when the machine is ready by illuminating GREEN to feed the next manually fed document. Located on the Feeder Door.

C. FILM CARTRIDGE:

(Shown in image C above)

- a) **CARTRIDGE** – inserts into the laminator.
- b) **CARTRIDGE LABEL** – indicates film thickness. Located on top of handle.
- c) **FILM LEADER** – the sealed leading edge of the film. This edge must be placed facing the exit of the machine.



OPERATION

OPERATION MODES:

AUTO FEED / AUTO CUT

Note: Best for standard paper sizes printed on 80-120 gsm paper.

1. Press the POWER button to turn the machine ON. The machine will automatically start in Auto Feed / Auto Cut mode.
2. Place your document(s) in the FEED TRAY.
3. Slide the Side Guides to fit your document(s) to minimise skew during lamination.
4. Press the RUN button:

Note: If RUN is pressed before the machine has completely warmed up, the status bar will be AMBER blinking in a sequence. The laminator has accepted the command and will start automatically when machine reaches proper temperature.

5. Document(s) will be automatically laminated and automatically trimmed as they exit the machine.

Note: If you hit stop while the document is still feeding through the laminator, the machine will finish laminating the document before stopping.

MANUAL FEED / AUTO CUT

Note: Best for standard rectangular paper sizes on heavy paper stocks that won't Auto Feed.

1. Press the POWER button to turn the machine ON.
2. Select the Manual Feed / Auto Cut mode by pressing the Mode button.
3. Wait for the machine to reach proper temperature: solid green STATUS light.
4. Place only the first document in the FEED TRAY. The document must be placed in the centre of the Feed Tray and far enough into the feeder to grab your document.
5. Press the RUN button. The document will begin to feed into the laminator.
6. After your first document begins laminating, wait for the MANUAL FEED indicator to illuminate green. Once illuminated, the machine can be manually fed the next document. Repeat this process one sheet at a time until the job is complete.
7. Documents will be manually laminated and automatically trimmed as they exit the machine.
8. After the final document has been cut and exits the machine will automatically stop.

MANUAL FEED / MANUAL CUT

Note: This mode is best used for odd-shaped or non-rectangular documents that won't Auto Feed.

1. Press the POWER button to turn the machine ON.
2. Select the Manual Feed / Manual Cut mode by pressing the Mode button.

3. Wait for the machine to reach proper temperature: solid green STATUS light.
4. Place only the first document in the FEED TRAY. The document must be placed in the centre of the Feed Tray and far enough into the feeder to grab your document.
5. Press the RUN button. The document will begin to feed into the laminator.
6. After your first document begins laminating, wait for the MANUAL FEED indicator to illuminate green. Once illuminated, the machine can be manually fed the next document. Repeat this process one sheet at a time until the job is complete.
7. Press the CUT button to cycle the trimmer anytime you want to cut the film.
Note: It is recommended to press the CUT button after you see the entire document exit the machine to avoid cutting the document.
8. After the final document has exited the machine, press the STOP button to stop the lamination process.
9. Once lamination has stopped, press CUT to cut the remaining film that has exited the machine.

CARTRIDGE FILM LOADING

(Reference Images 1-4 to demonstrate process)



CAUTION: the following procedure might be performed while the laminator is hot. Use extreme caution.

1. Open Laminator Door: Open the laminator door by fully raising the silver latch on the top of the machine and pull up until door fully opens.
 2. Remove Cartridge: Lift upward on the cartridge handle to remove the installed cartridge.
Caution: full cartridges tend to be heavy
 3. Insert Cartridge: Insert replacement cartridge by aligning edges of cartridge over grey channel guide in laminator and lowering.
- Note:** Film leader should be inserted away from the feeder, facing towards the exit of the machine.
4. Close Laminator Door: Close the laminator door by gently lowering the door and fully close the silver latch on top. DO NOT push down on the laminator door to close; use the latch.
 5. Ensure Cartridge is Fully Inserted: Film Empty indicator will be illuminated when no cartridge is installed or if the cartridge is not fully seated on the bottom.

Note: When the laminator reaches proper temperature, the machine will feed approximately 23cm of film to eliminate potential wrinkles in the film.

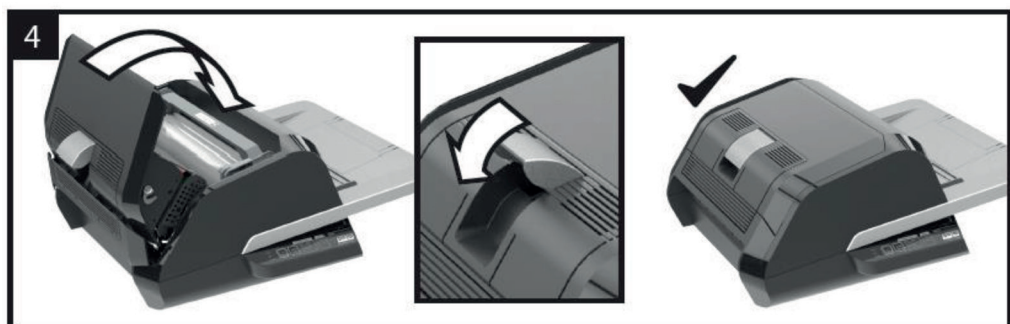
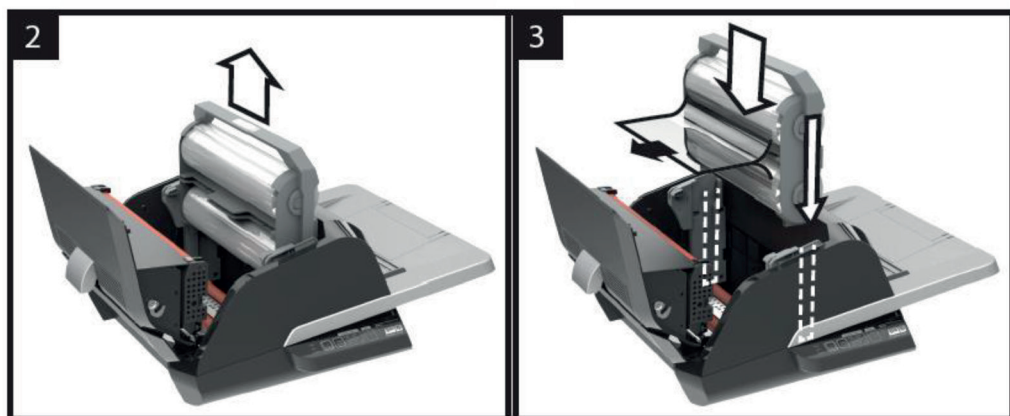
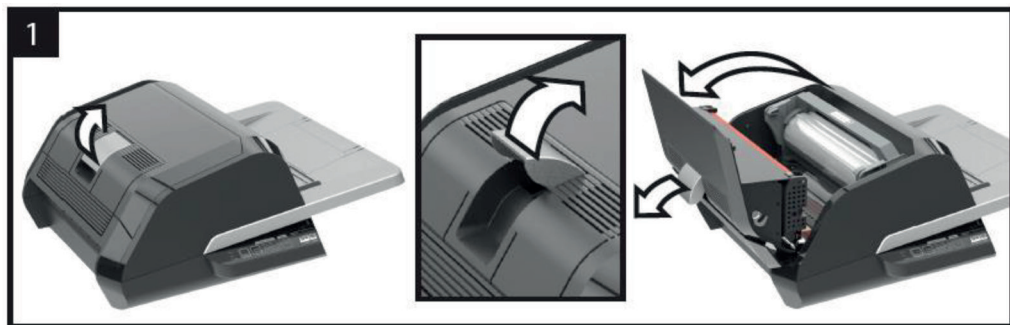



TROUBLESHOOTING

SYMPTOM	POSSIBLE CAUSE	CORRECTIVE ACTION
Pressing the Power button does not turn the machine ON	The power cord may not be inserted all the way into outlet	Fully Insert plug into outlet. Make sure the outlet has power.
Status Indicator Red:	<p>Door Error Indicator Red:</p> <p>Paper Jam Error Indicator Red:</p> <p>Film Empty Indicator Red:</p> <p>Cutter Error Indicator Red:</p>	<p>Remove any paper from the feeder tray. Open and Close both the laminator door and the feeder door. Ensure they are fully closed</p> <p>Remove any paper from the feeder tray. Open and close the feeder door. If the above does not clear the error, press and hold the RUN button for 10 seconds to manually feed film. Film should begin to exit the machine and Jam should clear. If Jam error remains, open laminator door and look to see if film leader is caught on an obstacle or the rollers. DO NOT CUT the film. Lift-up the film leader and replace it in proper position. Shut Laminator door and hold the run button for 10 Seconds.</p> <p>Cartridge End of Roll label has been detected. Replace the film cartridge with new cartridge and shut the laminator door.</p> <p>Press the manual cut button one time to try and activate the cutter. Not resolved, try the following: Press and hold the RUN button for about 10-20 seconds to manually advance the film. If there is laminated media in the exit of the laminator, hold the RUN button until the media has fully exited the laminator. Now press the manual cut button to see if the cutter is activated. If the film does not run, or if the cutter does not work after the above steps, contact your service provider.</p>
Film Wrinkles on output	Film Misaligned	<p>Press and hold the RUN button to manually advance the film. After 125 – 500mm of film has been advanced the wrinkle should work themselves out. If wrinkle clear press the manual cut button and you are ready to begin.</p> <p>If wrinkles still present, open the laminator door. Grasp the film exiting the laminator and hold it taut while closing the laminator door. Repeat above step and wrinkles should disappear.</p>
Film Edges are not evenly aligned.	Top and bottom rolls of film are not matched properly.	<p>Press and hold the RUN button to manually advance the film. After 125 mm of film has been advanced the film edges should be evenly aligned. If film edges are now evenly aligned, press the CUT button and you are ready to begin.</p> <p>If film edges are still not evenly aligned, open the laminator door. Grasp the film exiting the laminator and hold it taut while closing the laminator door.</p>

SYMPTOM	POSSIBLE CAUSE	CORRECTIVE ACTION
Documents are skewed in the film when exiting	Documents fed in skewed	<p>Before loading paper, try tapping the leading edge of the paper on a flat surface and then repeat with the bottom or top edge to get your paper properly squared.</p> <p>Insert your media in the auto feeder and slide the edge guide up to edge of your media.</p>
<p>Experiencing frequent double feeds</p> <p>Experiencing frequent mis-feeds</p>	<p>Paper has heavy static</p> <p>Rollers are slipping on media and do not feed sheets</p>	<p>Try fanning the media or placing in a paper jogger prior to feeding it. If issues persist use the Manual Feed / Auto Cut mode.</p>



SAFETY

Safety

YOUR SAFETY, AS WELL AS THE SAFETY OF OTHERS IS IMPORTANT TO GBC. IN THIS INSTRUCTION MANUAL AND ON THE PRODUCT ARE IMPORTANT SAFETY MESSAGES. BEFORE YOU INSTALL OR USE THE MACHINE, READ AND FOLLOW ALL THE SAFETY NOTICES CAREFULLY IN THIS CHAPTER.

Observe all the safety information provided. Observe all safety warnings. Never remove safety warnings or other information from the equipment.

Read all of the instructions and save these instructions for further use.



The safety alert symbol precedes each safety notice in this manual. The symbol indicates a potential personal safety hazard to you or others, as well as cause product damage or property damage.



Observe all the safety information provided. Observe all safety warnings. Never remove safety warnings or other information from the equipment.

THE FOLLOWING WARNINGS ARE FOUND ON THE FOTON 30 LAMINATOR



Do not open. No user serviceable parts inside. Refer servicing to qualified service personal.



CAUTION Hot Surface: Laminator rollers can be in excess of 260° F / 126.7° C. Please use caution and do not touch the rollers.



WARNING: Do not attempt to service or repair the laminator.



WARNING: Do not connect the laminator to an electrical supply or attempt to operate the laminator until you have completely read these instructions. Maintain these instructions in a convenient location for future reference.



WARNING: This device is not intended for use in the direct field of view at visual display workplaces. To avoid incoming reflections at visual display workplaces this device must not be placed in the direct field of view.

General Safeguards

- Use this laminator only for its intended purposes as according to the specifications outlined in the operating instructions.
- Keep hands, long hair, loose clothing and articles such as necklaces or ties away from the front of the feed rollers to avoid entanglement and entrapment.
- When opening the top door of the laminator, avoid contact with the internal rollers when laminator is powered on or shortly after the laminator has been turned off. The rollers can reach temperatures in excess of 260° F / 126.7° C.
- Keep hands and fingers away from the path of the sharp film cutter blade located at the film exit.
- Do not place the laminator on an unstable cart, stand or table. An unstable surface may cause the laminator to fall resulting in serious bodily injury. Avoid quick stops, excessive force and uneven floor surfaces when moving the laminator on a cart or stand.
- Do not defeat or remove electrical and mechanical safety equipment such as interlocks, shields and guards.
- Do not insert objects unsuitable for lamination.
- Do not expose laminator to liquids.



CAUTION: The receptacle must be located near the equipment and easily accessible. Do not use an extension cord.

Electrical Safeguards

- The equipment should be connected to an easily accessible and grounded (3-pin) receptacle (socket outlet) near the equipment.
- This laminator must be connected to a supply voltage corresponding to the electrical rating as indicated on the serial plate located on the rear of the machine.
- Unplug the laminator before moving it, or when it is not in use for an extended period of time.
- Do not operate the laminator with a damaged power supply cord or plug.
- Do not overload electrical outlets as this can result in fire or shock.
- Do not alter the attachment plug. This plug is configured for the appropriate electrical supply.
- The unit is intended for indoor use only.
- Disconnect the attachment plug from the receptacle to which it is connected and keep the power supply cord in your possession while moving the laminator.
- Do not operate the laminator with a damaged power supply cord or attachment plug, upon occurrence of a malfunction, or after laminator has been damaged. Contact an authorized GBC service representative for assistance.

Waste Electrical and Electronic Equipment (WEEE)

At the end of its useful life, your product is considered to be WEEE. As such, it is important to note that: WEEE is not to be disposed of as unsorted municipal waste. It is to be collected separately such that it can be disassembled so its components and materials can be recycled, re-used, and recovered (burned for energy content in the production of electricity).

Public collection points have been set up by municipalities for the collection of WEEE, free of charge to you.

Please return your WEEE to the collection facility nearest your home or office.

If you have difficulty locating a collection facility, the retailer that sold you the product should accept your WEEE.

If you are no longer in contact with your retailer, please contact ACCO for assistance with this matter.

Recycling of WEEE is geared toward protecting the environment, protecting human health, preserving raw materials, improving sustainable development, and ensuring a better supply of commodities in the European Union. This will be achieved by retrieving valuable secondary raw materials and reducing the disposal of waste. You can contribute to the success of these goals by returning your WEEE to a collection facility.

Your product is marked with the WEEE symbol (wheelie bin with an X through it). This symbol is to inform you that the WEEE is not to be disposed of as unsorted municipal waste.

Guarantee

Operation of this machine is guaranteed for two years from date of purchase, subject to normal use. Within the guarantee period, ACCO will at its own discretion either repair or replace the defective machine free of charge. Defects due to misuse or use for inappropriate purposes are not covered under the guarantee. Proof of date of purchase will be required. Repairs or alterations made by persons not authorised by ACCO will invalidate the guarantee. It is our aim to ensure that our products perform to the specifications stated. This guarantee does not affect the legal rights which consumers have under applicable national legislation governing the sale of goods.

