



EN

TOWER FAN

Aspire tower



OPERATING INSTRUCTION

Read the instructions carefully before operating the appliance or carrying out maintenance operations. Observe all the safety instructions; failure to observe the instructions may lead to accidents and/or damage. Keep these instructions in a safe place for future reference.

GENERAL SAFETY INFORMATION

- Use this fan only as outlined in this manual. Any other use not recommended by the manufacturer may cause fire, electric shock or injury to people.
- Ensure that the mains power complies with the voltage specified on the fan 's data plate (220-240V~/50Hz).
- This appliance can be used by children aged from 8 years and above and people with reduced physical, sensory or mental capabilities or lack of experience and knowledge if they have been given supervision or instruction concerning use of the appliance in a safe way and understand the hazards involved.
- Children shall not play with the appliance.
- Cleaning and user maintenance shall not be made by children without supervision.
- This product is not a toy. Children should be adequately supervised to ensure that they do not play with the appliance.
- Disconnect the mains power when the appliance is not used or for cleaning operations.
- Do not restrict the air inlet and outlet grilles.
- Ensure that all objects are at least 1 meter from the front and sides of the appliance.
- Avoid using the fan in dusty environments or in the presence of inflammable vapours (e.g. in workshops or garages) or paint vapours.
- Do not place anything on the appliance, use the appliance to dry clothing.
- Use the appliance in a well-ventilated area.
- Avoid placing fingers or foreign objects in the air inlet/outlet grilles, as this may lead to electric shock or fire and may damage the appliance.
- To avoid the risk of fire, do not block the grilles or tamper with them in any way while the fan operates.
- **Do not use the appliance if the cord or plug are damaged.** If the power supply cord is damaged, it must be replaced by the manufacturer, dealer or a similarly qualified person so as to avoid any safety risks.
- Do not operate the appliance if it has fallen from a height or has suffered damage in any way. Contact qualified technical

personnel to examine the appliance or perform any electrical or mechanical repairs.

- The most common cause of overheating is the build-up of dust in the appliance. Remove dust deposits by unplugging the appliance and cleaning the air outlets and grilles with the aid of a vacuum cleaner.
- Do not use abrasive detergents for cleaning this appliance. Clean the appliance with the aid of a damp (not wet) cloth rinsed in hot soapy water. Always remove the plug from the mains socket before cleaning.
- To disconnect the fan, push the switch to OFF and remove the plug from the socket. Pull on the plug only. Avoid pulling on the cord when disconnecting the fan.
- Do not place any objects on the cord and do not bend it.
- It is not advisable to use extension cords, as these may overheat and cause the risk of fire. Do not use a single extension cord to operate multiple appliances.
- Do not immerse the cord, plug or any other element of the appliance in water or other liquids.
- Do not touch the plug with wet hands.
- Do not place the fan above or near another heat source.

WARNING: AVOID COVERING THE FAN TO PREVENT IT FROM OVERHEATING.

The symbol below signals the above warning:



WARNING: AVOID COVERING THE FAN TO PREVENT IT FROM OVERHEATING.

- The fan may cause the risk of fire if, while in operation, is covered by or comes into contact with **flammable** material including curtains, drapery, blankets, etc. **KEEP THE FAN AWAY FROM THESE MATERIALS.**
- Do not connect the appliance to the mains power before it has been properly assembled and positioned.
- Do not run the cord under carpets. Do not cover the cord with blankets, carpets or similar materials. Place the cord far away from busy areas or where it cannot be accidentally pulled-out.
- Do not operate the fan in close proximity to bathtubs, showers, washbasins or pools.

- Do not position the fan below a socket outlet.
- Do not operate the appliance outdoors.

WARNING: do not use the fan with a controller or any other external device that activates the appliance automatically, as there may be a risk of fire if the fan is covered or incorrectly positioned.

WARNING: DO NOT DEPEND ON THE ON/OFF BUTTON SWITCH AS THE SOLE MEANS OF DISCONNECTING POWER. WHEN SERVICING OR MOVING THE FAN, ALWAYS UNPLUG THE POWER CORD.

- A fan has hot and arcing or sparking parts inside. It must not be used in potentially dangerous locations such as flammable, explosive, chemical-laden or wet atmosphere.
- Do not place the fan on soft surfaces, like a bed, where openings may become blocked. Always place the fan on a stable, flat, level surface when operating, to avoid the chance of the overturning.
- Locate the power cord so the fan or other objects are not resting on it.
- Always unplug the fan when not in use.
- In order to avoid accidents turn unit off if unattended.
- In the event of any problems (abnormal noise or a strange smell) switch off the appliance immediately, do not attempt to repair it and take it to your local after sales service.

ASSEMBLY INSTRUCTIONS

1. Open the box and remove the parts of the appliance.
2. Spin 3 screws out from the turnplate. (Picture 1)
3. Fasten the back base and front base each other. (Picture 2)
4. Align with the base and turnplate screw, then spin into 3 screws. (Picture 3)
5. Press the power cord into the line deduction. (Picture 4)

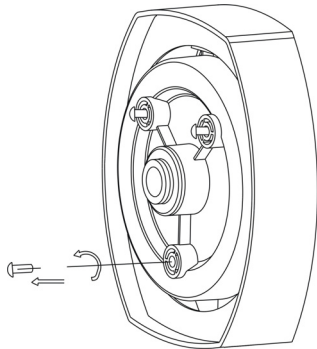

Picture 1

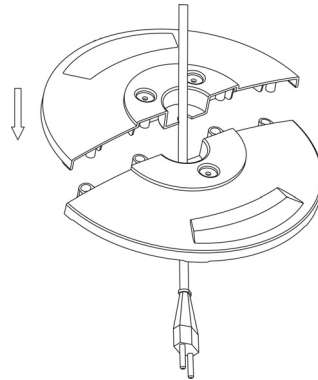

Picture 2

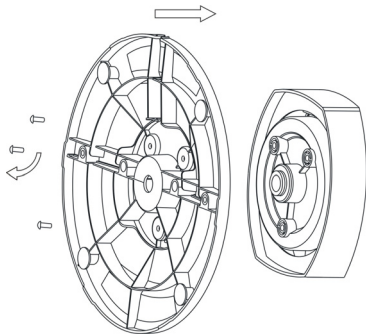

Picture 3

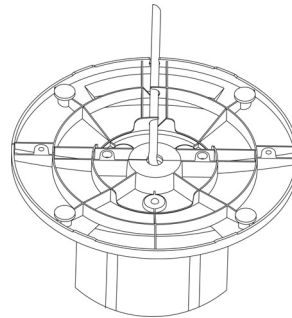

Picture 4

DESCRIPTION OF PARTS

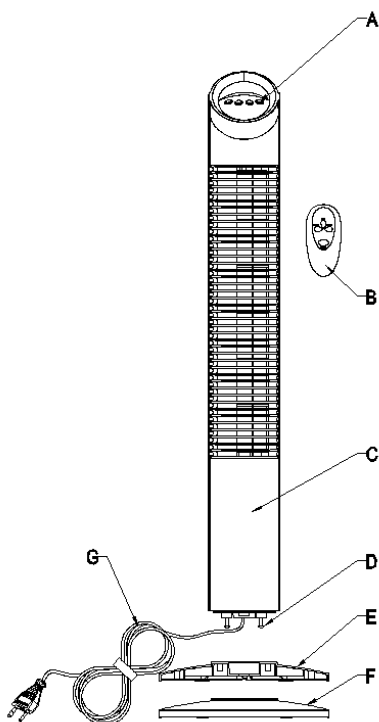

- a. Switch knob
- b. Remote control
- c. Body
- d. Screw
- e. Back base
- f. Front base
- g. Power cord

HOW TO USE THE APPLIANCE

The appliance does not need to be installed.
When you move the appliance, use the handle on the back.

CONTROL PANEL AND AVAILABLE FUNCTIONS

ON/OFF button

Touch the ON/OFF button on the control panel or remote control. A sound will indicate that the appliance is on and on the digital display the POWER indicator and the medium SPEED indicator (MID) lights on. To switch off the fan press the button again.

SPEED button

Touching the button SPEED the fan speed increase from LOW to MEDIUM to HIGH.

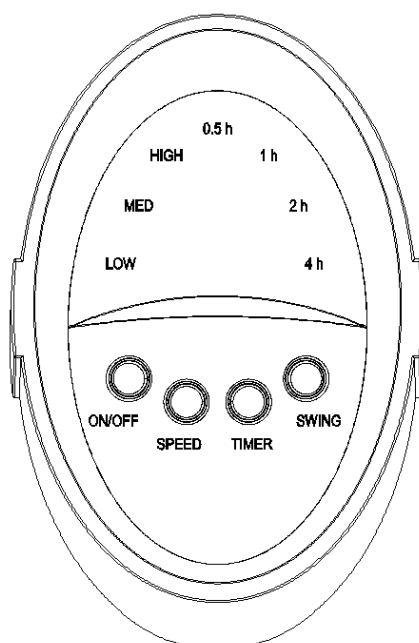

SWING button

When the appliance is operating, touch this button to make the appliance oscillate automatically, shifting the air flow from left to right. Touch the button SWING again to interrupt the oscillation.

TIMER button

When the appliance is operating, the operating time can be set by touching the TIMER button by 30 minutes step, up to 7,5 hours. The TIMER DISPLAY is switched on simultaneously and shows the time set. The unit will switch off automatically at the end of the programmed time.

TELECOMANDO

The remote control has four buttons whose functions are identical to those on the control panel (already illustrated in detail).

HOW TO INSERT / REMOVE THE REMOTE CONTROL BATTERIES (not provided)

Open the battery cover on the back of the remote control (press and pull the cover). Place the batteries inside the cover, making sure the polarity is correct. Slot the cover back into position on the remote control. Use cells model no. LR03AAA 1,5V, compliant with Battery Directive no. 2006/66/EC. Remove the batteries when not using the remote control for a long period of time.

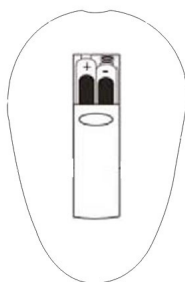



INFORMATION FOR CORRECT DISPOSAL OF THE BATTERIES IN ACCORDANCE WITH EUROPEAN DIRECTIVE 2006/66/EC

Please replace the battery when its electrical charge has been exhausted: at the end of its useful life, it must not be disposed of together with unsorted waste. It must be must be delivered to appropriate separated waste disposal plants or to dealers that provide a similar service. Separate waste disposal of batteries prevents potential negative effects on the environment and human health resulting from inadequate disposal, and also allows the materials from which it is made to be recovered and recycled in order to achieve significant savings in terms of energy and resources. The separate disposal obligation is underlined by the crossed-out dustbin symbol appearing on the battery. Illegal disposal of the product by the user shall result in the application of administrative sanctions as defined by current regulations.

MAINTENANCE AND STORAGE

**ALWAYS UNPLUG THE APPLIANCE BEFORE CLEANING OR MAINTENANCE.
IMPORTANT: DO NOT SUBMERGE THE FAN IN WATER.**

Cleaning the outside surface of the appliance

Turn the switch off and unplug before carrying out any maintenance work or moving the appliance.

Use a soft cloth to remove any dust from the fan.

If the fan is excessively dirty, use a soft cloth moistened with water and a mild detergent at a temperature lower than 50°C. Let the fan dry completely before use.

Do not use corrosive detergents or solvents such as petrol. Do not wash the appliance with water. Do not use oils, chemical substances or other items to clean that may damage the surface.

Use a vacuum cleaner to remove dust from the air inlet/outlet grilles.

STORAGE

If the appliance is not used for prolonged periods, disconnect the power cord and store the appliance with this manual in its original packaging, in a cool and dry place.



INFORMATION FOR THE CORRECT DISPOSAL OF THE PRODUCT IN ACCORDANCE WITH EUROPEAN DIRECTIVE 2012/19/EU

This appliance may not be scrapped with domestic waste at the end of its life cycle. We call your attention to the crucial role played by the consumer in the re-use, recycling and other forms of recovery of such waste.

The appliance must be scrapped by a sorted waste disposal centre or by returning it to the retailer (no charge is levied for this service), when you purchase a new equivalent appliance.

Sorted disposal of electric and electronic equipment prevents the negative effects on the environment and human health resulting from improper scrapping, and also allows the materials from which it is made to be recovered and recycled, with significant savings in terms of energy and resources.

The sorted disposal requirement is indicated by the crossed waste bin label affixed to the appliance.



www.argoclima.com

MADE IN CHINA